

**MADI Bridge**  
**Network I/O**  
**User Guide**  
Revision: 3.2



# Solid State Logic

O X F O R D • E N G L A N D

Visit SSL® at  
[www.solidstatelogic.com](http://www.solidstatelogic.com)

© Solid State Logic

All rights reserved under International and Pan-American Copyright Conventions  
SSL and Solid State Logic are ® registered trademarks of Solid State Logic.

SSL®, Solid State Logic®, Total Recall® and Tempest®  
are ® registered trademarks of Solid State Logic.

System T™, Live L100™, Live L200™, Live L300™, Live L350™, Live L500™, Live L500 Plus™,  
Live L550™, Blacklight™ and X-Light are ™ trademarks of Solid State Logic.

Dante™ and Audinate™ are trademarks of Audinate Pty Ltd.

etherCON® is a registered trademark of Neutrik AG.

All other product names and trademarks are the property of their respective owners  
and are hereby acknowledged.

No part of this publication may be reproduced in any form or by any means,  
whether mechanical or electronic, without the written permission of  
Solid State Logic, Oxford, OX5 1RU, England.

As research and development is a continual process, Solid State Logic reserves the right to change  
the features and specifications described herein without notice or obligation.

Solid State Logic cannot be held responsible for any loss or damage arising directly or indirectly from  
any error or omission in this manual.

**PLEASE READ ALL INSTRUCTIONS, PAY SPECIAL HEED TO SAFETY WARNINGS.**

E&OE

April 2023

## Document Revision History

<b>First Version</b>		March 2014
<b>Revision 2.0</b>	Split mode MADI and SRC functions included	November 2014
<b>Revision 3.0</b>	MADI Control Mode added and format revision	June 2018
<b>Revision 3.1</b>	Singlemode and Multimode variants added	May 2021
<b>Revision 3.2</b>	Correction to Singlemode and Multimode part numbers	April 2023

**Table of Contents**

<b>Introduction</b>	<b>4</b>	<b>Dante Controller</b>	<b>18</b>
Overview	4	Network Config	18
Key Features	4	Device Info	18
MADI Bridge Front Panel	4	User and Control Bit Pass-Through	19
MADI Bridge Rear Panel	4	Brooklyn Reset	19
Virtual Headphone Patch	5	<b>Clocking Scenarios</b>	<b>20</b>
Audio Channel Names	5	Network of Consoles With House Sync	20
<b>Usage Cases</b>	<b>6</b>	Clocking from the Network	20
MADI Connectivity for a System T Network	6	<b>Appendix A – Specifications</b>	<b>21</b>
Dante Network I/O Integration for MADI Consoles	6	Physical	21
Leveraging Existing Network Infrastructure	6	Ventilation	21
Building a Distributed and Expandable MADI Router	7	Group Delay	21
Redundant or Split Mode MADI	7	<b>Appendix B - Supported Sync Rates</b>	<b>22</b>
<b>Hardware Connections</b>	<b>8</b>	Unsupported Rates	22
Mains Power Connections	8	<b>Appendix C - MADI Split Monitoring</b>	<b>23</b>
Dante Connections	8	<b>Appendix D - GPIO Pinouts</b>	<b>27</b>
MADI	8	<b>Appendix E – Safety Notices</b>	<b>28</b>
Clock	9	General Safety	28
GPIO	9	Installation Notes	28
<b>Software Features</b>	<b>10</b>	Power Safety	29
Info Menus	10	For EU	29
LOCK	10	Environmental Declaration	30
MON	11	RoHS Notice	30
Options Menus	12	For USA	30
Error Indication	12	Electromagnetic Compatibility	30
MADI	13	Environmental	30
REDU	14		
CLOCK	15		
SRATE	16		
MODE	17		

## Introduction

### Overview

MADI Bridge is an interface between a routable Audio-over-IP network and MADI (AES10). SSL Network I/O products use Audinate's Dante technology to transport audio, plus discover and configure multiple devices on the network. Using Dante results in seamless and reliable interoperability with third party Dante products, this is further expandable with AES67 compatibility.

With 64 channels per MADI Bridge (at 48 kHz) and up to 512 channels per 1 Gb network link, Dante is fully scalable and capable of providing routing channel counts from tens to thousands and beyond using standard IT infrastructure. Redundant PSUs, MADI and IP Network ports mean the MADI Bridge is built for uninterrupted operation, keeping critical devices and audio paths functioning throughout the system. In addition to the inbuilt clock redundancy options in Dante Controller, the MADI Bridge also includes a pair of redundant sync inputs for use as a self-redundant Dante Grand Master clock.

The MADI Bridge features a front panel headphone socket (with rotary level control) and inbuilt headphone monitor routing, to replace traditional patchbay routing and fault finding functionality with equivalents in the IP audio domain. Simple front panel controls facilitate routing mono or stereo paths from MADI In, MADI Out, Dante In or Dante Out directly to the headphones. A front panel OLED screen provides signal present metering, selectable to show four points in the signal chain: MADI In, MADI Out, Dante In and Dante Out. GPIO connections allow the transfer of tallies and switching functions across the same network as the audio.

### Key Features

- Interface between MADI and IP Audio Networks using Dante and AES67
- Bi-directional sample rate conversion between any asynchronous sample rates, from 44.1 kHz to 192 kHz
- Redundant PSUs, singlemode or multimode MADI ports, Dante ports, sync inputs
- MADI Split Mode
- GPIO connectivity - embed tallies across the network
- Redundant Network Extension ports - add local IO or control without a switch
- Wordclock out - clock a MADI device to the Dante network
- Virtual Headphone Patch
- Lockout mode - prevent accidental alteration of front panel settings

### MADI Bridge Front Panel

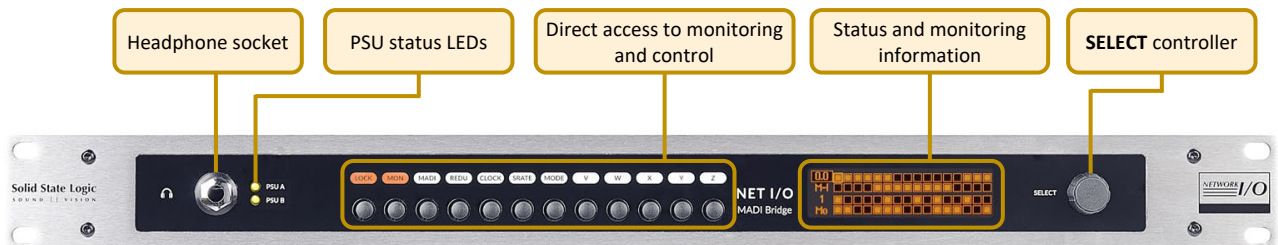

### MADI Bridge Rear Panel

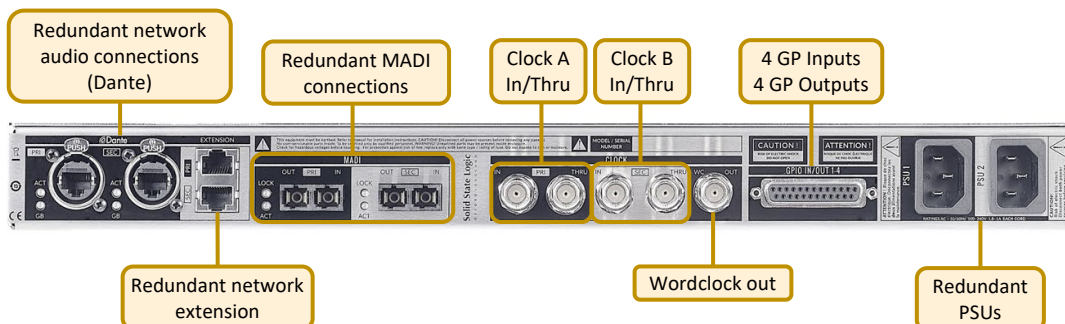

## Virtual Headphone Patch

Monitoring and signal present metering is provided for incoming and outgoing MADI and Dante ports. It replaces patchbay based routing with a digital network whilst retaining confidence and fault finding tools.

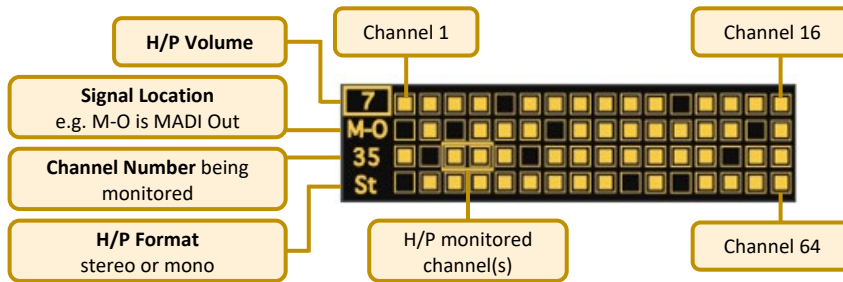

## Audio Channel Names

The name of the signal (as set in Dante Controller) being transmitted or received over the network can be displayed in the status and monitoring window for the selected channels.

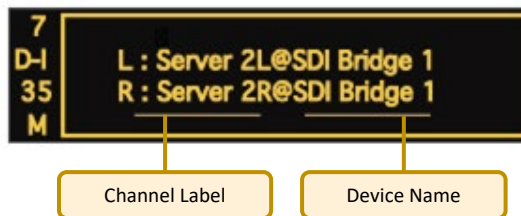

## Usage Cases

**N.B.** The following diagrams omit secondary network connections for clarity.

### MADI Connectivity for a System T Network

This provides MADI connectivity available to all networked System T consoles. The MADI Bridge can also be used as a clock master for the Dante network or to provide external TDM devices with a clock source.

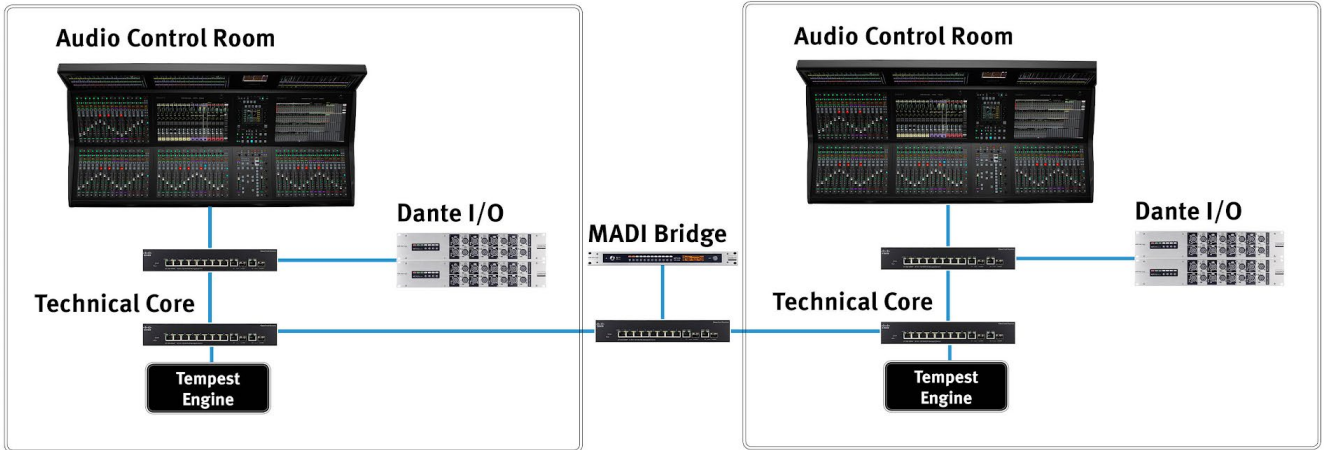

### Dante Network I/O Integration for MADI Consoles

This allows the addition of Dante networked devices to existing MADI infrastructure.

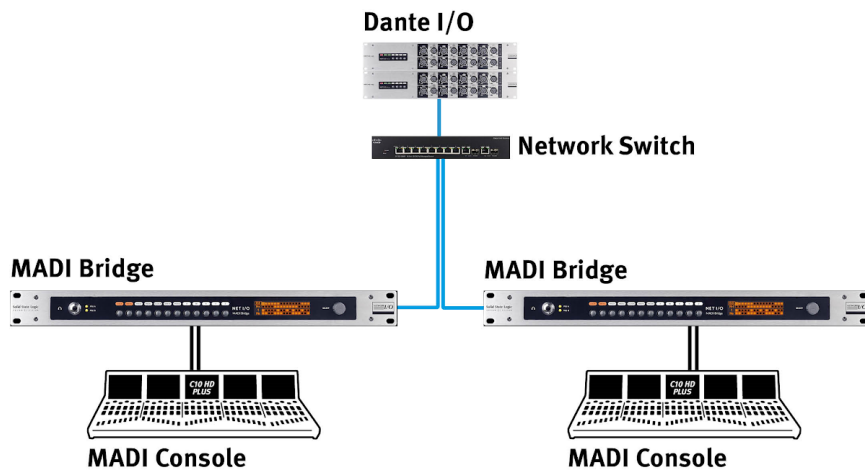

### Leveraging Existing Network Infrastructure

Up to 8 MADI streams can be transmitted through 1 Gb bandwidth - 512 channels at 48 kHz in each direction.

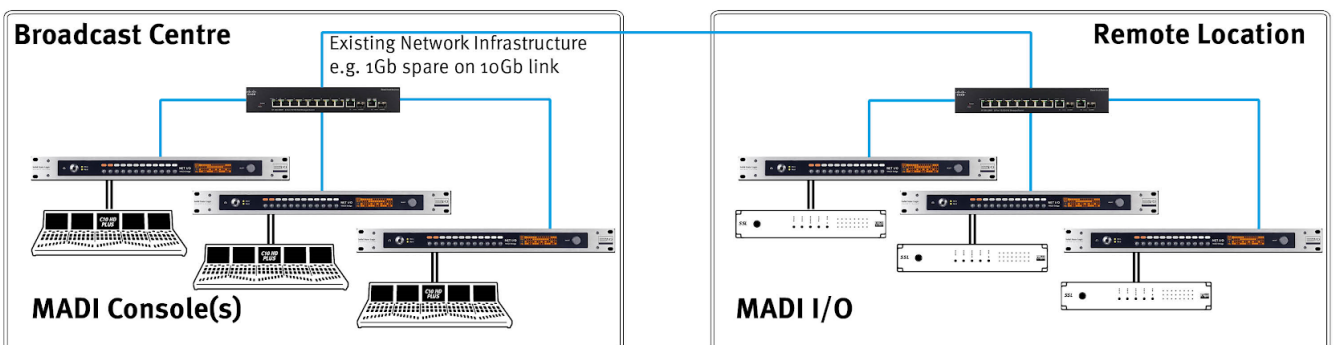

*Building a Distributed and Expandable MADI Router*

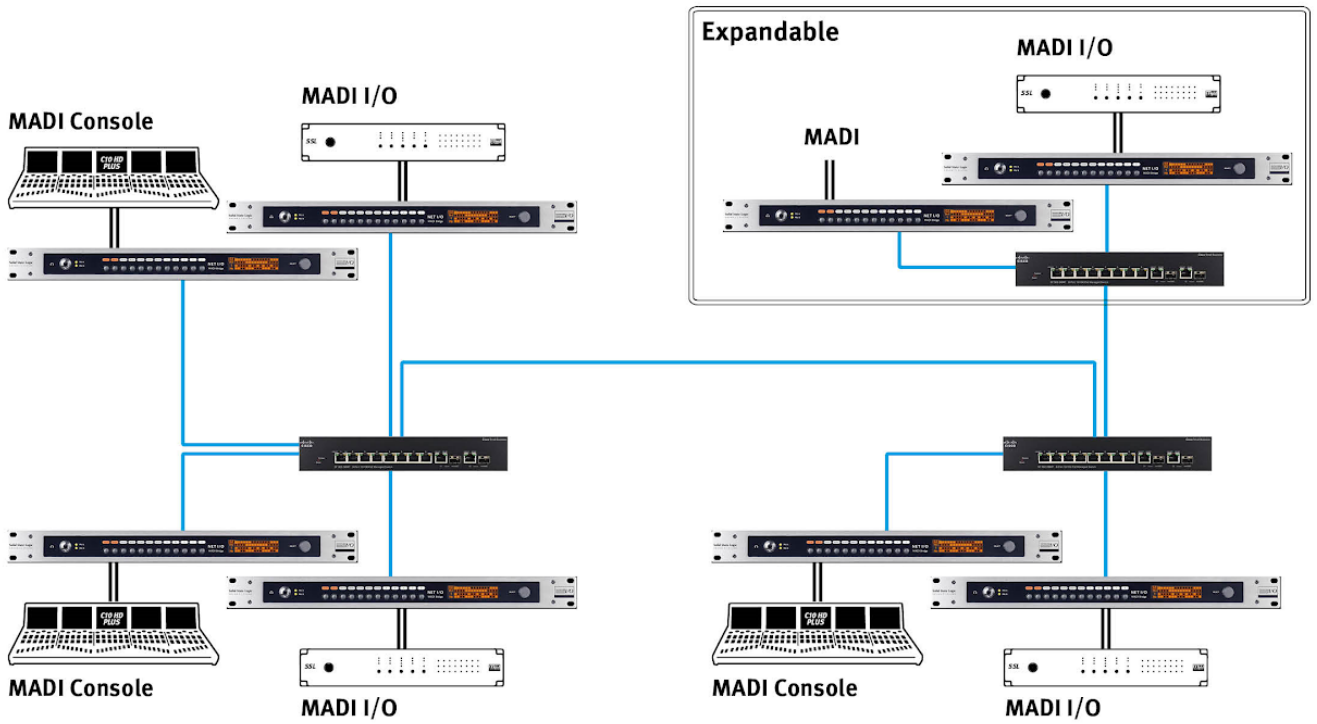

*Redundant or Split Mode MADI*

The secondary MADI input can be used as a redundant backup of the primary input, or as a second MADI input when in Split Mode. Here the MADI channel allocation is divided between the ports, dependant on the MADI and Dante sample rates. Full Split Mode channel allocation details are shown in [Appendix C](#).

**Redundant Mode**

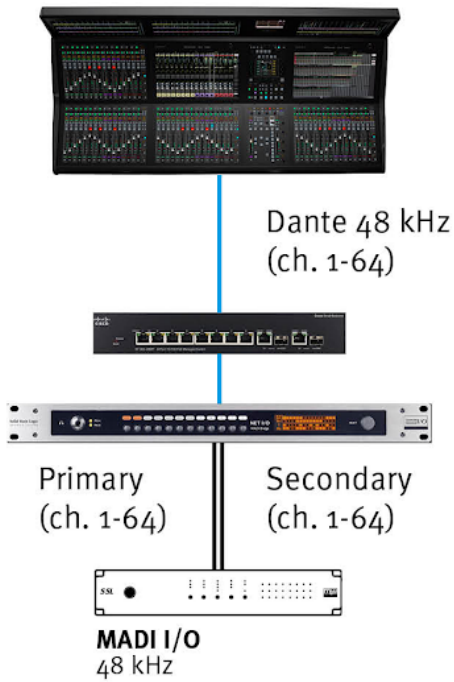

**Split Mode**

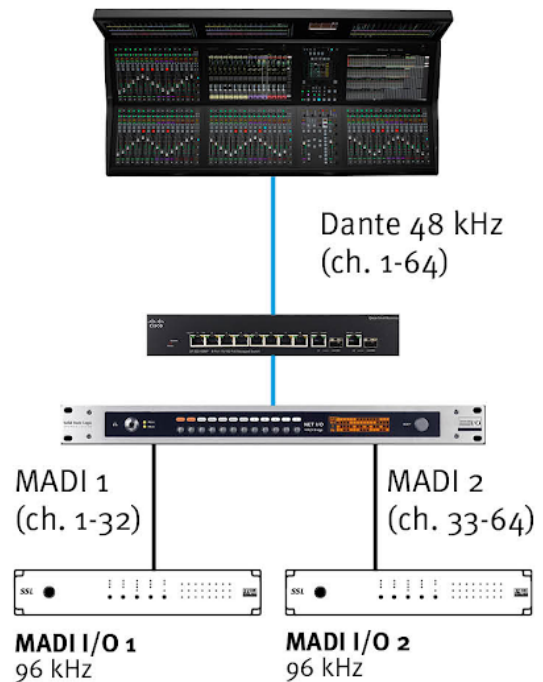



## Hardware Connections

### Mains Power Connections

The MADI Bridge includes redundant PSUs with IEC connectors; either supply can individually power the unit. Ideally these should be connected to separate power circuits to provide redundancy of incoming AC power.

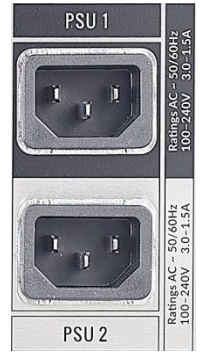

### Dante Connections

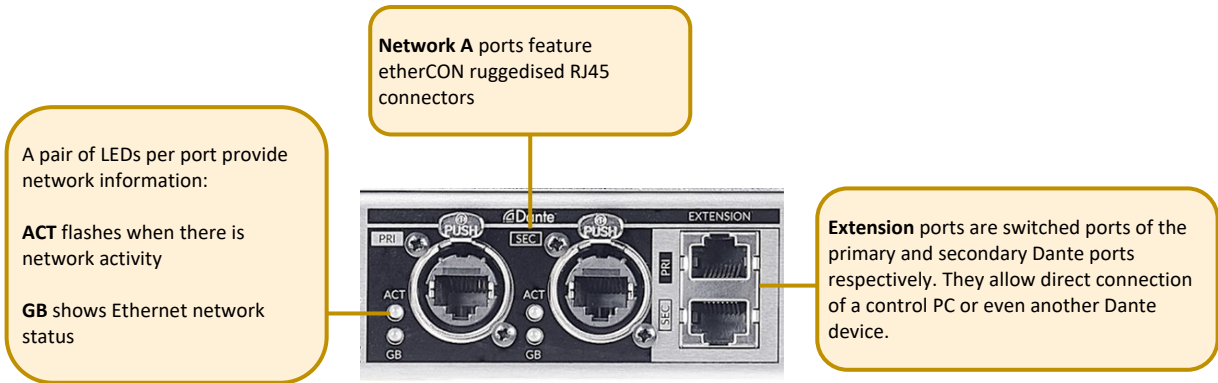

MADI Bridge has two redundant sets of network connections.

Note: Some Dante devices allow Dante ports to be set to **Switched** mode rather than **Redundant** mode. MADI Bridge uses the extension ports to provide this functionality, without loss of redundancy.

Never connect Primary and Secondary ports to the same single Dante network.

### MADI

Two hardware variants of MADI Bridge are available, providing singlemode (SSL part 726919X2) or multimode (SSL part 726920X3) fibre connectivity.

The multimode variant supports 62.5/125 µm or 50/125 µm multimode fibre.

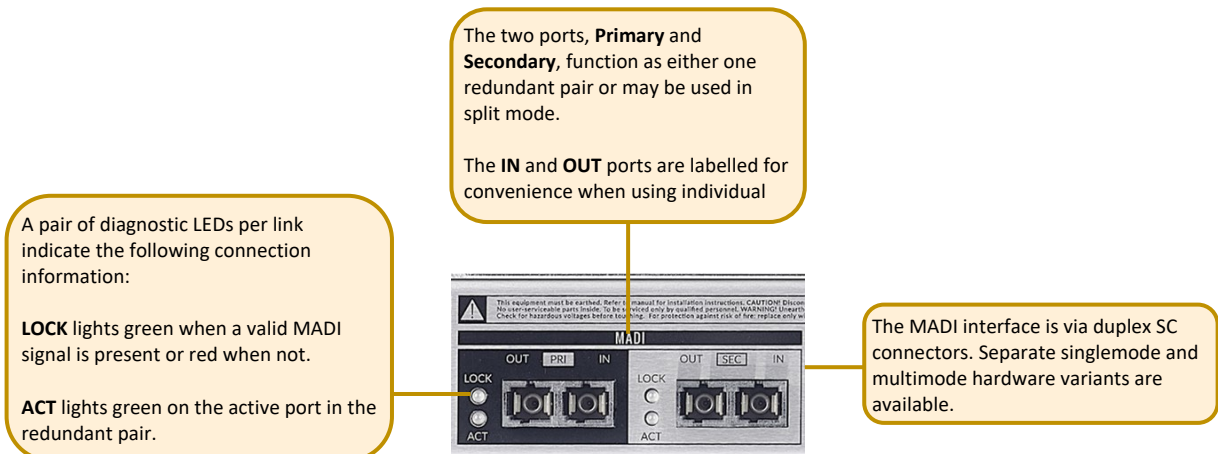



## Clock

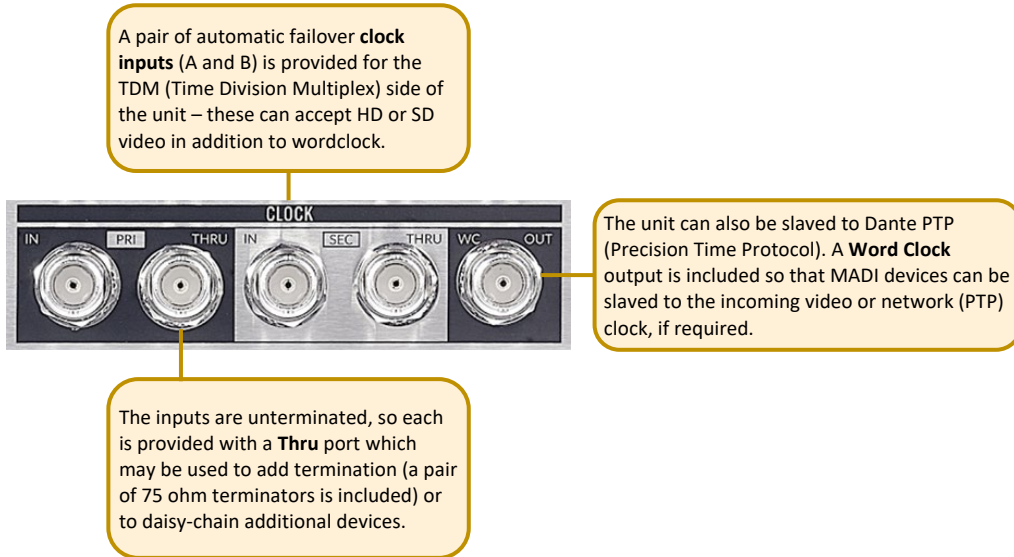

See [CLOCK](#) for setup details and [Clocking Scenarios](#) for additional information.

## GPIO

4 General Purpose opto-coupled inputs and 4 General Purpose relay outputs allow embedding and de-embedding of logic signals across the network.



See [Appendix D](#) for pinout information.

## Software Features

The front panel interface is designed to be intuitive to allow access to any function that needs to change using minimal button presses. Each menu has its own individual radio button that navigates to the desired page on the OLED. The other front panel control is the **SELECT** encoder which can be rotated, pushed or pushed-and-held.

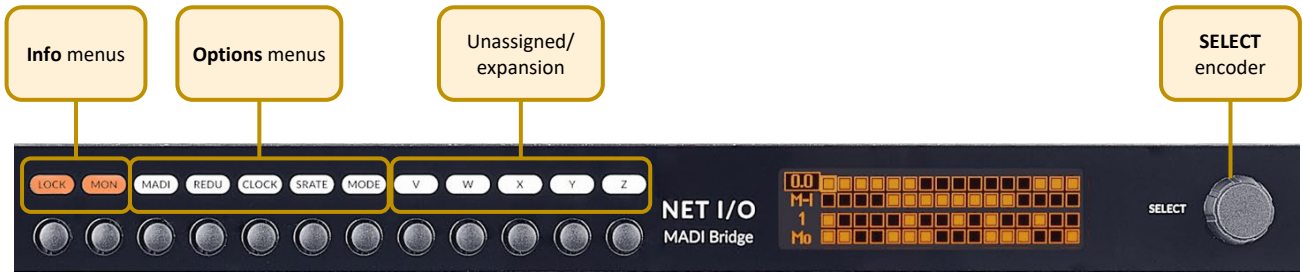

### Info Menus

The info menus are accessed by individual buttons to instantly navigate to the desired settings page on the OLED display. These menus are:

- LOCK** – Front panel lockout and device information
- MON** – Metering and headphone monitoring

### LOCK



The LOCK button is dual function: it both locks the front panel and displays the info screen on the OLED Display. MADI Bridge automatically locks-out the front panel after 60 seconds of the **SELECT** encoder or button inactivity. After a total of 2 minutes of inactivity the OLED display enters a screensaver mode. To unlock the front panel, press and hold the **LOCK** button for 3 seconds. When already in the **LOCK** menu, pressing and holding the **LOCK** button for 3 seconds will lock the front panel.

Note that the Monitor (**MON**) menu remains accessible even whilst in front panel lockout.

**N.B.** Holding both the **LOCK** and **Z** buttons together for 3 seconds restarts the MADI Bridge.

The default **Info** page shows the following information:

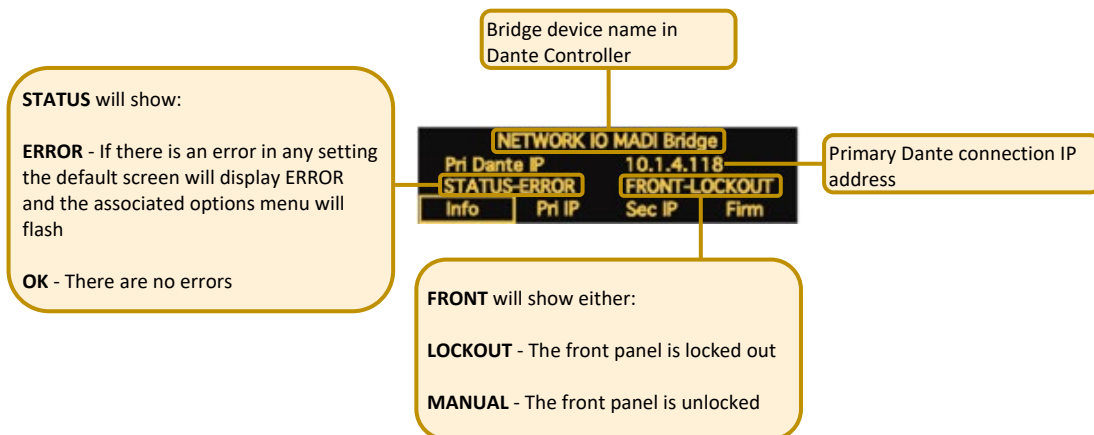

Turning the **SELECT** encoder scrolls through the info pages:

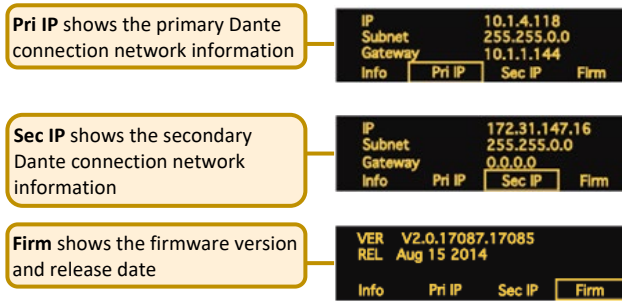

**MON**



Pressing the **MON** button brings up the **Monitor** menu or **Channel Name** page. Press the **MON** button again to navigate between these pages. The chosen page will be remembered when navigating to the **MON** page in future.

When in the **Monitor** menu, rotating the **SELECT** encoder alters the parameter highlighted by the focus box on the left. Pushing the encoder scrolls down through the 4 options. These options are:

- Headphone volume
- Signal location
- Channel number
- Format

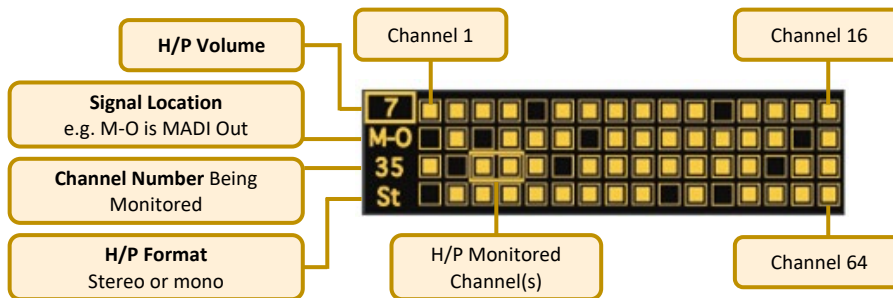

By default when entering the monitoring page the encoder will adjust the headphone volume. Pressing the **SELECT** encoder will move the focus to alter **Signal Location**. The options are:

- **M-I** MADI Input
- **M-O** MADI Output
- **D-I** Dante Input
- **D-O** Dante Output

When **Channel Number** is in the focus box rotating the encoder moves through the channels. This is displayed both by the channel number and the focus box around the signal present meters.

**Format.** When a Stereo channel is selected the left channel number is displayed and the focus box surrounds 2 signal present meters.

The **Channel Name** view displays the 'Channel Label' name as entered in Dante Controller. When looking at D-I or M-O the name displayed will be the channel label and the device that is routed to the unit across the network.

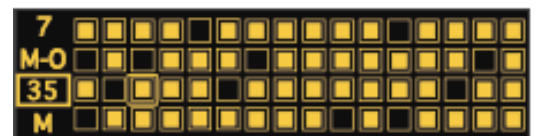
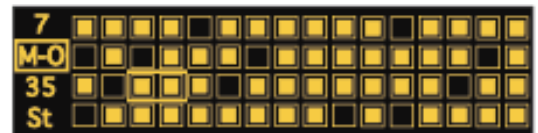

## Options Menus

The Options menus include parameters to be changed from the front panel and display information that needs to be known when changing options. These menus are:

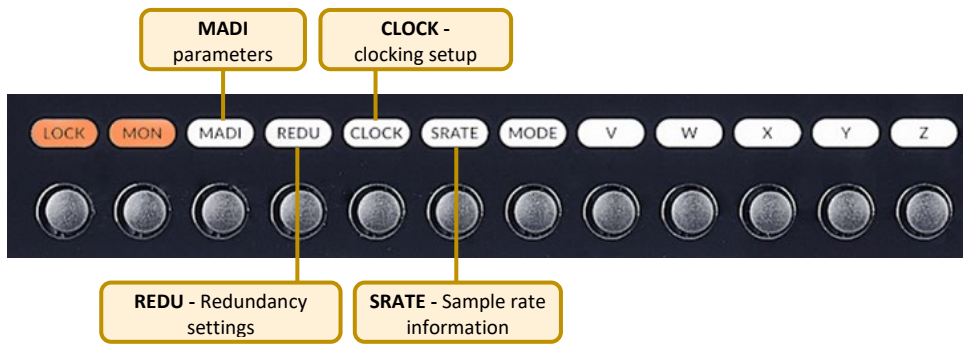

The Options menus are accessed by individual buttons to instantly navigate to the desired settings page on the OLED Display. The front panel must be unlocked for these buttons to function.

Within each Options menu the OLED display is divided into four focus sections:

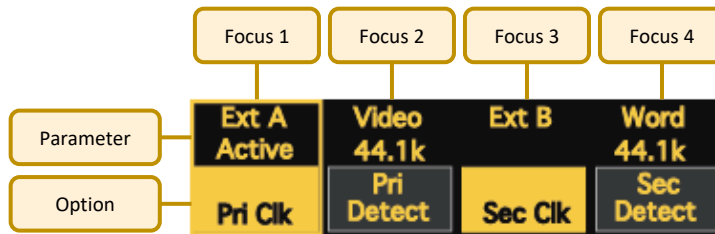

The lower half of each focus box displays the option to be changed, the upper half displays the parameter it is currently set to. Turning the **SELECT** encoder moves the focus window across the 4 sections.

The action taken when pressing the **SELECT** encoder differs depending on the colour of the box in the lower half of the focus window: a yellow option toggles through the parameters, a grey option requires a press and hold (3 seconds) to engage a detect routine or to force a special state, a solid black option indicates information only (**SELECT** has no function).

## Error Indication

Errors will cause the appropriate Options menu button LED to flash, indicating which menu needs attention or where information relating to the error's cause can be found. If an error occurs the MADI Bridge front panel will automatically unlock and be prevented from entering the screensaver mode until the error is resolved. Causes for error indication are shown in the following **REDU**, **CLOCK** and **SRATE** sections.

MADI



The **MADI** menu allows you to set the MADI settings. This is used to match the MADI parameters with those of another MADI device for valid interoperability.

Pressing the **MADI** menu button brings up the MADI menu. With the focus box selected to **MADI Mode**, pressing the encoder cycles through the MADI mode options (**Auto**, **64ch**, **56ch**, **32ch**, **28ch**, **16ch**, **14ch**).

64ch 64ch	ON	48k	Pri
MADI Mode	SRC	MADI SRate	MADI R State

The options available depend on the MADI sample rate.

- MADI sample rates of 192 or 176.4 kHz allow **14** or **16** channel mode
- MADI sample rates of 96 or 88.2 kHz allow **28** or **32** channel mode
- MADI sample rates of 48 or 44.1 kHz allow **56** or **64** channel mode
- **Auto** mode will detect the format of the incoming MADI stream and display the channel number
- **Auto** mode will display **ERROR** if the channel mode cannot be determined

Auto ERROR	OFF	88.2k	Pri
MADI Mode	SRC	MADI SRate	MADI R State

Legacy (SMUX) format MADI at 192, 96 or 88.2 kHz is not supported.

**N.B.** It is not advised to use two devices with auto-detect modes at either end of a MADI link.

Turning the encoder clockwise moves the yellow focus box to the **SRC** option. Pressing the encoder toggles the sample rate converters on and off.

32ch 32ch	ON	96k	Split Mode
MADI Mode	SRC	MADI SRate	MADI R State

In the **MADI SRATE** window pressing the encoder has no function. The MADI sample rate is derived from the primary clock input – see **CLOCK** and **SRATE** menus.

64ch 64ch	ON	48k	Pri
MADI Mode	SRC	MADI SRate	MADI R State

The fourth focus window shows **MADI R State** as displayed in the **REDU** menu.

32ch 32ch	OFF	96k	Pri
MADI Mode	SRC	MADI SRate	MADI R State

**N.B.** The MADI Tx continues to function when a MADI Rx signal is not received. While this is a perfectly usable state for some scenarios, the units error flagging will treat this as an error as there is no MADI Rx signal. When in this state:

- The front panel will show an error as there is no valid MADI Rx signal
- The unit will not lock the front panel buttons
- The unit's OLED will not enter screen saver mode
- The Monitoring feature will be unavailable for all signal points: MADI In, MADI Out, Dante In and Dante out

REDU



The **REDU** (Redundancy) menu allows you to set up the MADI redundancy options when interfacing various MADI devices. In addition, it provides fault-finding tools to continuity-check the validity of MADI signals directly from the front panel, or instigate Forced Override should you need to override the automatic redundancy mode.

Pressing the **REDU** menu button brings up the MADI **Redund Mode** Options Menu. With the focus box selected on **Redund Mode** pressing the encoder toggles through the options:

None	Split Mode	Valid	Valid
Redund Mode	MADI R State	Pri MADI Rx	Sec MADI Rx

- **SSL** – SSL mode is for integration with SSL consoles that turn off the MADI signal on the dormant port
- **GPI** – The Bridge defaults to the primary MADI input but can be forced to the secondary by triggering GP input 1  
*For GPIO pinouts refer to [Appendix D](#).*
- **None** – The MADI ports are now in Split Mode  
**None (Split) mode is not available at 176.4 or 192 kHz sample rates. For channel allocation details refer to [Appendix C](#).**

Turning **SELECT** clockwise moves the focus box to the **MADI R State** option, pressing **SELECT** has no function. The option reports the MADI redundancy state and as such the MADI input bridged to Dante (**Pri, Sec, Pri Error, Split Mode**).

SSL	Pri	Valid	Dark
Redund Mode	MADI R State	Pri MADI Rx	Sec MADI Rx

When in **GPI** mode this reports the GPI state. When in **SSL** mode this reports the active MADI port, or if both are active reports **Pri Error**, as one MADI connection should be 'dark'. In **SSL** mode, if neither port is active, the unit defaults to the primary port.

SSL	Pri Error	Valid	Valid
Redund Mode	MADI R State	Pri MADI Rx	Sec MADI Rx

Turning **SELECT** clockwise moves the focus box to **Pri MADI Rx**, this option is primarily for reporting only. However, for fault-finding and recovery this can be used to force MADI to the primary port. Pressing and holding **SELECT** for 3 seconds will put the MADI Bridge into *Force Primary Override* mode.

SSL	Pri	Valid	Dark
Redund Mode	MADI R State	Pri MADI Rx	Sec MADI Rx

While in this state the display will say **Force** and the **REDU** menu LED will flash to warn that **Force** mode has been enabled. Pressing and holding **SELECT** again for 3 seconds will revert to normal operation.

GPI	Sec	Force	Valid
Redund Mode	MADI R State	Pri MADI Rx	Sec MADI Rx

There is also a *Force Secondary Port Override* option when focus is on **Sec MADI Rx**. Press and hold **SELECT** for 3 seconds to engage and revert to standard.

SSL	Pri	Valid	Dark
Redund Mode	MADI R State	Pri MADI Rx	Sec MADI Rx



CLOCK



The **CLOCK** menu allows you to set the primary and secondary clock sources and enable the *Auto Detect* routine for each source.

Pressing the **CLOCK** menu button brings up the Clock page. With **Pri Clk** in the focus window pressing the **SELECT** encoder cycles through the clock options (**Ext A, MADI, Dante**).

Ext A Active	Video 44.1k	Ext B	Word 44.1k
Pri Clk	Pri Detect	Sec Clk	Sec Detect

The clock source selected in **Pri Clk** is not enabled until the *Auto Detect* routine is enabled in **Pri Detect**.

Turning **SELECT** clockwise moves the focus box to Primary Detect. Pressing and holding **SELECT** for 3 seconds starts the auto detect routine; this lasts for 20 seconds.

Ext A Active	Video 44.1k	Ext B	Word 44.1k
Pri Clk	Pri Detect	Sec Clk	Sec Detect

When Ext A is the **Pri Clk** source the Auto Detect will determine if the attached clock is video or wordclock. If the source is wordclock it will determine the sample rate; if the source is video the video sample rate will need to be set in the **SRATE** menu.

Turning **SELECT** again moves the focus to **Sec Clk**, pressing **SELECT** cycles through the options (**Ext B, MADI, Dante, None**).

Ext A Active	Video 44.1k	Ext B	Word 44.1k
Pri Clk	Pri Detect	Sec Clk	Sec Detect

**None** should be used to disable the secondary clock input if nothing is required.

Again the secondary clock Auto Detect routine can be enabled by pressing and holding the **SELECT** encoder when **Sec Detect** is in focus.

Ext A	Video 44.1k	Ext B Active	Word 44.1k
Pri Clk	Pri Detect	Sec Clk	Sec Detect

**N.B.** With **SRC** on, the clocking options do not include Dante. Dante clocking is determined in Dante Controller.

The **CLOCK** LED will flash if the MADI Bridge has swapped over to the secondary clock. A manual detection of the primary clock is needed to force it to the primary clock.



SRATE



Sample rate reporting and setting if using video sync.

Pressing the **SRATE** menu button brings up the Sample Rate menu. If the primary clock is MADI, Dante or wordclock it automatically detects the sample rate using the primary clock Auto Detect routine in the **CLOCK** menu.

44.1k	44.1k	44.1k	44.1k
Pri Clk Info	Sec Clk Info	MADI Info	Dante Info

If the primary clock source is video this option becomes manual (signified by being highlighted yellow) – pressing **SELECT** toggles through the sample rate options (**44.1, 48, 88.2, 96, 176.4** and **192** kHz).

44.1k	44.1k	44.1k	44.1k
Pri Clk Info	Sec Clk Info	MADI Info	Dante Info

Turning **SELECT** clockwise moves the focus box to **Sec Clk Info**. If the secondary clock is MADI, Dante or wordclock it automatically detects the sample rate using the secondary clock Auto Detect routine enabled in the **CLOCK** menu.

44.1k	44.1k	44.1k	44.1k
Pri Clk Info	Sec Clk Info	MADI Info	Dante Info

If the secondary clock source is video this option becomes manual (signified by being highlighted yellow) – pressing **SELECT** toggles through the sample rate options (**44.1, 48, 88.2, 96, 176.4** and **192** kHz).

44.1k	44.1k	44.1k	44.1k
Pri Clk Info	Sec Clk Info	MADI Info	Dante Info

With the focus box on **MADI Info** the encoder has no function, the **MADI Info** sample rate follows that of the primary clock sample rate.

44.1k	44.1k	44.1k	44.1k
Pri Clk Info	Sec Clk Info	MADI Info	Dante Info

With the focus box on **Dante Info** the encoder has no function, **Dante Info** reports the Dante sample rate set for the MADI Bridge from Dante Controller.

44.1k	44.1k	44.1k	44.1k
Pri Clk Info	Sec Clk Info	MADI Info	Dante Info

The **SRATE** LED will flash if the sample rates do not match and **SRC** is switched off.

## MODE



The **MODE** menu allows you to set the **Control Mode**. The **Control Mode** setting is required when AES user and control bits are to be transported between devices on the Dante network.

**N.B.** On older design MADI Bridge devices the **MODE** button is labelled **U**.

To enable the pass-through of AES user and control bits the MADI Bridge must be set to **PCM 32 encoding** within Dante Controller. Changing the encoding setting is detailed in the [Dante Controller](#) section of this guide.

**N.B.** When set to 32-bit encoding the audio remains 24-bit. The additional 8 bits are used to transport the user and control bits from the AES10 signal.

Pressing the **MODE** menu button brings up the Control Mode page. If 32-bit encoding is enabled then pressing the **SELECT** encoder cycles through the available options (**SSL**, **AES10**).

- **SSL** mode is a legacy mode previously for use with SSL devices such as the Alpha-Link LIVE. **AES10** mode should now be used when control data is required.



**N.B.** For **SSL Control Mode** (and any other manufacturers' control modes using higher audio channels and user bits for control) all audio channels must be routed one-to-one between the two MADI Bridge devices.

- **AES10** mode enables transparent pass-through of the user and control bits from the signal



If the MADI Bridge is set to PCM 24 encoding the **Control Mode** will be fixed to **None**. No user or control bits will be passed through.



## Dante Controller

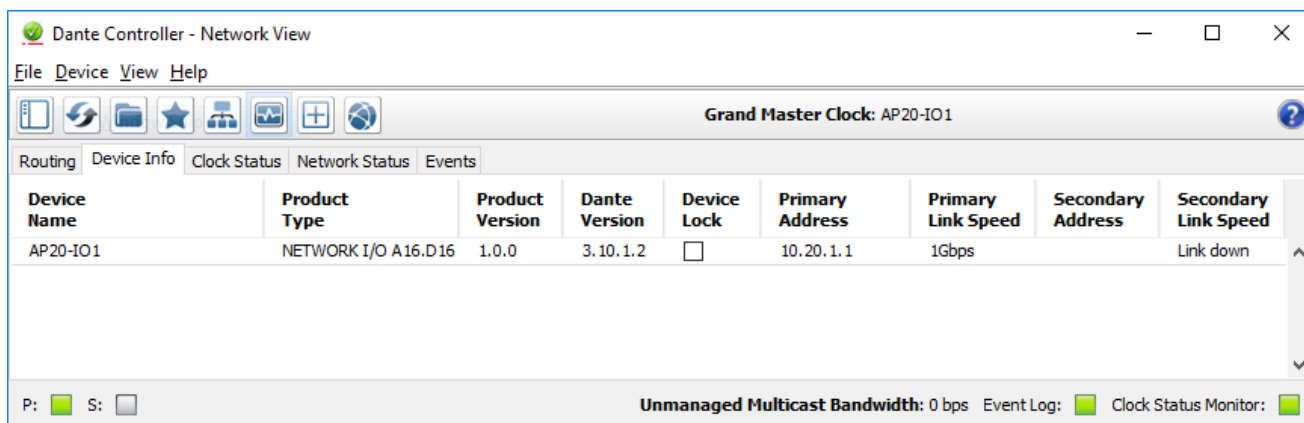

Refer to Audinate’s Dante Controller user guide for complete information on Dante Controller software. The information below details the basics required to get started.

Clock sync, device naming and network management are all done within Dante Controller.

Dante utilises the device name for routing. Each device must have a unique name – if a name is duplicated it will be appended with a number.

### Network Config

Each device requires its own unique IP address. This may be automatically configured, provided by a DHCP server or assigned manually. Unless shipped as part of a preconfigured system, Network I/O units are set to obtain an IP address automatically.

If the IP settings need to be changed to a fixed address – to match the network environment in which the unit is to be installed – this can be achieved using the Dante Controller application.

Remember that the computer’s network adapter configuration will also need to be updated to match the Network I/O.

The primary and secondary ports must not be connected to the same logical network. Ideally, separate switching hardware should be provided for primary and secondary networks. Creating VLANs on shared hardware is acceptable but does not provide the most robust redundancy.

The Default display in the **LOCK** mode shows the primary IP address; in this way you will always be able to access the device regardless of what mode the network ports are set to.

### Device Info

The **Device Info** tab shows an overview of all devices on the Dante network including name, product type, software version, IP address, link speed and status.

**Device > Device View** provides configuration and diagnostics for each device including Tx and Rx subscription and signal status, software and firmware version information, network utilisation and real-time latency measurement, as well as configuration of device name, sample rate, bit depth, latency, IP address and AES67 parameters. The **Network Config** tab provides IP address configuration options.

The device will resolve to a link-local address if it is set to obtain an IP address automatically and no DHCP server is present. To access via link-local, set your computer to obtain an IP address automatically, directly connect to the device’s primary port and wait for the link-local addresses to resolve. Link-local addresses for the Primary Dante interfaces obtain IP addresses in the 169.254.xxx.xxx range, secondary Dante interfaces obtain addresses in the 172.31.xxx.xxx range.

### *User and Control Bit Pass-Through*

To enable the pass-through of AES user and control bits the device must be set to 32-bit encoding (**PCM 32**). This is set within the **Encoding** section of the **Device Config** tab.

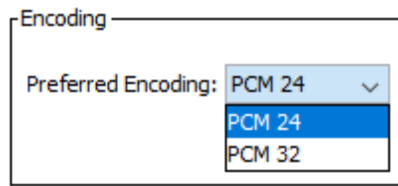

### *Brooklyn Reset*

Resetting the Dante Brooklyn card to default settings is performed from Dante Controller. Under the **Device Config** tab for a device select **Clear Config**. This clears the device name, channel labels, IP address settings, sample rate, latency and existing audio routes.

## Clocking Scenarios

### Network of Consoles With House Sync

This setup shows a network containing multiple consoles. Two are shown but the principles would remain the same for a larger network. House synchronisation is provided to multiple MADI Bridge devices, these are set to 'Enable sync to external' within Dante Controller. This provides the network with redundant master clock sources referenced to the house synchronisation. One device would be elected as the Grand Master Clock for the Dante network, if that were to fail another MADI Bridge would take the role of Grand Master.

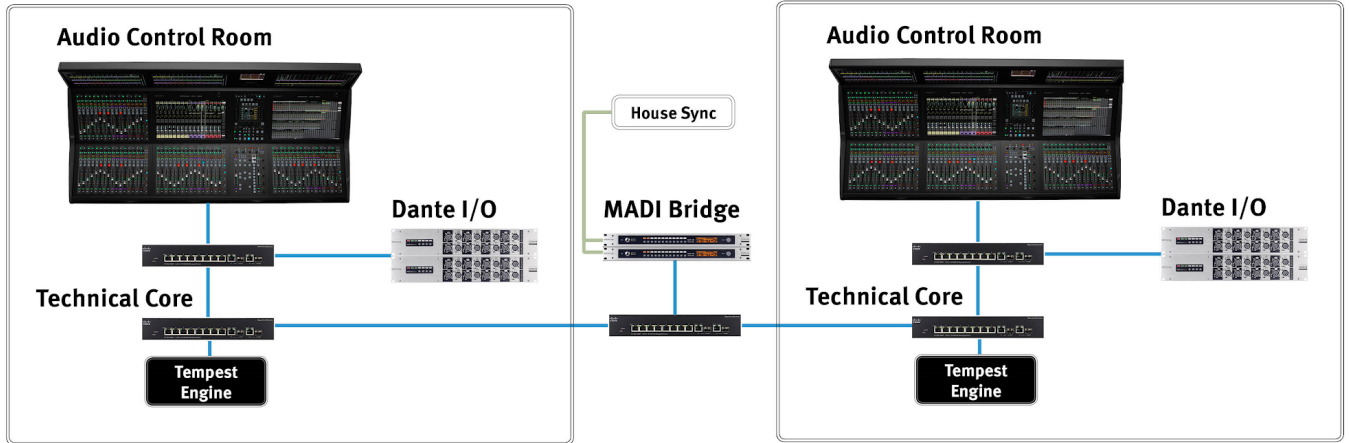

### Clocking from the Network

In this example a MADI Bridge receives a redundant external sync signal. This MADI Bridge is set to Sync to External within Dante Controller. The remaining MADI Bridges will derive their own clock from the master device. This can be fed to external TDM devices using the MADI Bridge wordclock outputs.

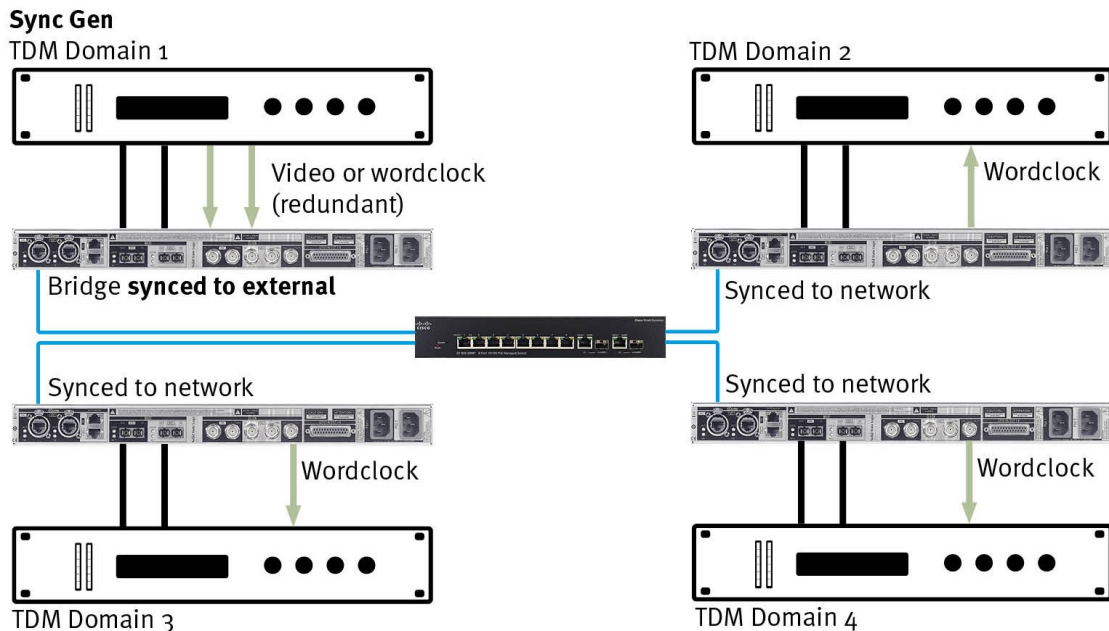

## Appendices

### Appendix A – Specifications

#### *Physical*

Parameter	Value	Notes
<b>Depth</b>	200 mm ( 7.75")	
<b>Height</b>	44.5 mm ( 1.75")	1 RU
<b>Width</b>	438 mm ( 17.25") 482 mm ( 19")	Excluding rack ears Including rack ears
<b>Weight</b>	3.1 kg ( 6.8 lb)	
<b>Power</b>	< 20 W	
<b>Boxed Size</b>	630 x 310 x 130 mm ( 25 x 12 x 5.5")	
<b>Boxed Weight</b>	4 kg ( 8.8 lb)	

#### **Ventilation**

Ventilation is from the side of the unit.

#### *Group Delay*

Parameter	Value	Notes
<b>Group delay (no SRC)</b>	8 samples	MADI to Dante module*
<b>Group delay (with SRC)</b>	51 samples	MADI to Dante module*

\*Group delay does not include the deterministic Dante device latency which can be specified in Dante Controller.

Appendix B - Supported Sync Rates

Video Format	Field Rate (Hz)	Frame Rate (Hz)	Notes
PAL	50	25	SD
PAL 24	48	24	
NTSC	59.94	29.97	
1080i 60 Hz	60	30	HD
1080i 59.94 Hz	59.94	29.97	
1080i 50Hz	50	25	
1080p 60 Hz	60	60	
1080p 59.94 Hz	59.94	59.94	
1080p 50 Hz	50	50	
1080p 30 Hz	30	30	
1080p 29.97 Hz	29.97	29.97	
1080p 25 Hz	25	25	
1080p 24 Hz	24	24	
1080p 23.976 Hz	23.976	23.976	
1080PsF 24 Hz (1080i 48 Hz)	24	24	
1080PsF 23.976 Hz (1080i 47.95 Hz)	23.976	23.976	
720p 60 Hz	60	60	
720p 59.94 Hz	59.94	59.94	
720p 50 Hz	50	50	

*Unsupported Rates*

Video Format	Field Rate (Hz)
PAL	23.976
720p	30
720p	29.97
720p	25
720p	24
720p	23.976



## Appendix C - MADI Split Monitoring

The following diagrams show the number of MADI channels available – and the associated front panel displays – for each setting of MADI sample rate, Dante sample rate, channel count and split/redundant mode.

The diagram to the right indicates the number of channel slots available for audio (or silence) in each operating mode.

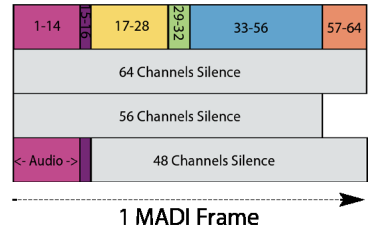

### 48kHz Dante

MADI Port Primary	MADI Port Secondary	MADI Status Display	Monitor Signal Display MADI: M-I or M-O	Monitor Signal Display Dante: D-I or D-O
<b>48kHz MADI – Redundant</b>				
64ch		* 64ch OFF 48k Pri MADI SRC MADI MADI Mode SRate R State	7 35 St M-O	7 35 St D-O
56ch		* 56ch OFF 48k Pri MADI SRC MADI MADI Mode SRate R State	7 35 St M-O	7 35 St D-O
<b>48kHz MADI – Split Mode</b>				
64ch		* 64ch OFF 48k Split Mode MADI SRC MADI MADI Mode SRate R State	7 35 St M-O	7 35 St D-O
56ch		* 56ch OFF 48k Split Mode MADI SRC MADI MADI Mode SRate R State	7 35 St M-O	7 35 St D-O
<b>96kHz MADI – Redundant</b>				
32ch		32ch ON 96k Pri MADI SRC MADI MADI Mode SRate R State	7 35 St M-O	7 35 St D-O
28ch		28ch ON 96k Pri MADI SRC MADI MADI Mode SRate R State	7 35 St M-O	7 35 St D-O
<b>96kHz MADI – Split Mode</b>				
32ch		32ch ON 96k Split Mode MADI SRC MADI MADI Mode SRate R State	7 35 St M-O	7 35 St D-O
28ch		28ch ON 96k Split Mode MADI SRC MADI MADI Mode SRate R State	7 35 St M-O	7 35 St D-O
<b>192kHz MADI – Redundant</b>				
16ch		16ch ON 192k Pri MADI SRC MADI MADI Mode SRate R State	7 35 St M-O	7 35 St D-O
14ch		14ch ON 192k Pri MADI SRC MADI MADI Mode SRate R State	7 35 St M-O	7 35 St D-O











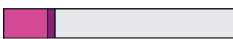
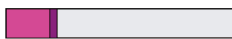





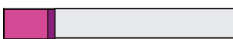







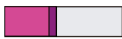



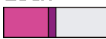
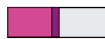



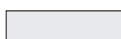

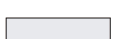

\* SRC can be on or off.

† In split mode operation the break between the channels is indicated by the dotted line – the first channel of the lower section becomes channel 33 or 29 and is the start of the secondary MADI port. The channel number mapping between MADI and Dante always follows the channel numbers.



# MADI Bridge User Guide

## 192kHz Dante

MADI Port Primary	MADI Port Secondary	MADI Status Display	Monitor Signal Display MADI: M-I or M-O	Monitor Signal Display Dante: D-I or D-O								
<b>48kHz MADI – Redundant</b>												
64ch 		<table border="1"> <tr><td>64ch</td><td>ON</td><td>48k</td><td>Pri</td></tr> <tr><td>MADI Mode</td><td>SRC</td><td>MADI SRate</td><td>MADI R State</td></tr> </table>	64ch	ON	48k	Pri	MADI Mode	SRC	MADI SRate	MADI R State		
64ch	ON	48k	Pri									
MADI Mode	SRC	MADI SRate	MADI R State									
56ch 		<table border="1"> <tr><td>56ch</td><td>ON</td><td>48k</td><td>Pri</td></tr> <tr><td>MADI Mode</td><td>SRC</td><td>MADI SRate</td><td>MADI R State</td></tr> </table>	56ch	ON	48k	Pri	MADI Mode	SRC	MADI SRate	MADI R State		
56ch	ON	48k	Pri									
MADI Mode	SRC	MADI SRate	MADI R State									
<b>48kHz MADI – Split Mode</b>												
64ch 		<table border="1"> <tr><td>64ch</td><td>ON</td><td>48k</td><td>Split Mode</td></tr> <tr><td>MADI Mode</td><td>SRC</td><td>MADI SRate</td><td>MADI R State</td></tr> </table>	64ch	ON	48k	Split Mode	MADI Mode	SRC	MADI SRate	MADI R State		
64ch	ON	48k	Split Mode									
MADI Mode	SRC	MADI SRate	MADI R State									
56ch 		<table border="1"> <tr><td>56ch</td><td>ON</td><td>48k</td><td>Split Mode</td></tr> <tr><td>MADI Mode</td><td>SRC</td><td>MADI SRate</td><td>MADI R State</td></tr> </table>	56ch	ON	48k	Split Mode	MADI Mode	SRC	MADI SRate	MADI R State		
56ch	ON	48k	Split Mode									
MADI Mode	SRC	MADI SRate	MADI R State									
<b>96kHz MADI – Redundant</b>												
32ch 		<table border="1"> <tr><td>32ch</td><td>OFF</td><td>96k</td><td>Pri</td></tr> <tr><td>MADI Mode</td><td>SRC</td><td>MADI SRate</td><td>MADI R State</td></tr> </table>	32ch	OFF	96k	Pri	MADI Mode	SRC	MADI SRate	MADI R State		
32ch	OFF	96k	Pri									
MADI Mode	SRC	MADI SRate	MADI R State									
28ch 		<table border="1"> <tr><td>28ch</td><td>OFF</td><td>96k</td><td>Pri</td></tr> <tr><td>MADI Mode</td><td>SRC</td><td>MADI SRate</td><td>MADI R State</td></tr> </table>	28ch	OFF	96k	Pri	MADI Mode	SRC	MADI SRate	MADI R State		
28ch	OFF	96k	Pri									
MADI Mode	SRC	MADI SRate	MADI R State									
<b>96kHz MADI – Split Mode</b>												
32ch 		<table border="1"> <tr><td>32ch</td><td>OFF</td><td>96k</td><td>Split Mode</td></tr> <tr><td>MADI Mode</td><td>SRC</td><td>MADI SRate</td><td>MADI R State</td></tr> </table>	32ch	OFF	96k	Split Mode	MADI Mode	SRC	MADI SRate	MADI R State		
32ch	OFF	96k	Split Mode									
MADI Mode	SRC	MADI SRate	MADI R State									
28ch 		<table border="1"> <tr><td>28ch</td><td>OFF</td><td>96k</td><td>Split Mode</td></tr> <tr><td>MADI Mode</td><td>SRC</td><td>MADI SRate</td><td>MADI R State</td></tr> </table>	28ch	OFF	96k	Split Mode	MADI Mode	SRC	MADI SRate	MADI R State		
28ch	OFF	96k	Split Mode									
MADI Mode	SRC	MADI SRate	MADI R State									
<b>192kHz MADI – Redundant</b>												
16ch 		<table border="1"> <tr><td>16ch</td><td>ON</td><td>192k</td><td>Pri</td></tr> <tr><td>MADI Mode</td><td>SRC</td><td>MADI SRate</td><td>MADI R State</td></tr> </table>	16ch	ON	192k	Pri	MADI Mode	SRC	MADI SRate	MADI R State		
16ch	ON	192k	Pri									
MADI Mode	SRC	MADI SRate	MADI R State									
14ch 		<table border="1"> <tr><td>14ch</td><td>ON</td><td>192k</td><td>Pri</td></tr> <tr><td>MADI Mode</td><td>SRC</td><td>MADI SRate</td><td>MADI R State</td></tr> </table>	14ch	ON	192k	Pri	MADI Mode	SRC	MADI SRate	MADI R State		
14ch	ON	192k	Pri									
MADI Mode	SRC	MADI SRate	MADI R State									

\* SRC can be on or off.

## MADI Bridge User Guide

The following table shows the number of MADI channels available for each setting of Dante sample rate, MADI sample rate, channel count and split/redundant mode.

Dante Sample Rate (kHz)	Dante Channel Count	MADI Sample Rate (kHz)	MADI Channel Count	MADI Redundancy State	Channels Transmitted from MADI Primary	Channels Transmitted From MADI Secondary		
44.1/48	64	44.1/48	64	Redundant	64	64*		
			56	Redundant	56	56*		
			64	Split	32	32		
			56	Split	28	28		
		88.2/96	32	Redundant	32	32*		
			28	Redundant	28	28*		
			32	Split	32	32		
			28	Split	28	28		
		176.4/192	16	Redundant	16	16*		
			14	Redundant	14	14*		
		88.2/96	32	44.1/48	64	Redundant	32	32*
					56	Redundant	32	32*
64	Split				32	0		
56	Split				32	0		
88.2/96	32			Redundant	32	32*		
	28			Redundant	28	28*		
	32			Split	32	0		
	28			Split	28	4		
176.4/192	16			Redundant	16	16*		
	14			Redundant	14	14*		
176.4/192	16			44.1/48	64	Redundant	16	16*
					56	Redundant	16	16*
		64	Split		16	0		
		56	Split		16	0		
		88.2/96	32	Redundant	16	16*		
			28	Redundant	16	16*		
			32	Split	16	0		
			28	Split	16	0		
		176.4/192	16	Redundant	16	16*		
			14	Redundant	14	14*		

\* The secondary MADI port is a redundant backup to the primary MADI port. These channels will replace the primary MADI port channels in the event of a failure/manual changeover to the secondary MADI port.

## Appendix D - GPIO Pinouts

### GP Outputs

All output switch closures are via DIL relay.

**DO NOT** use these outputs to directly switch capacitive or reactive loads; always use a separate external relay with suitable contact rating.

### DIL Relay Ratings:

- 100 V DC, 125 V AC
- 100 mA max.

### GP Inputs

Inputs are triggered by applying an AC or DC voltage of between 4 V and 24 V. The current drawn is approximately 10 mA. Minimum input pulse duration 50 ms.

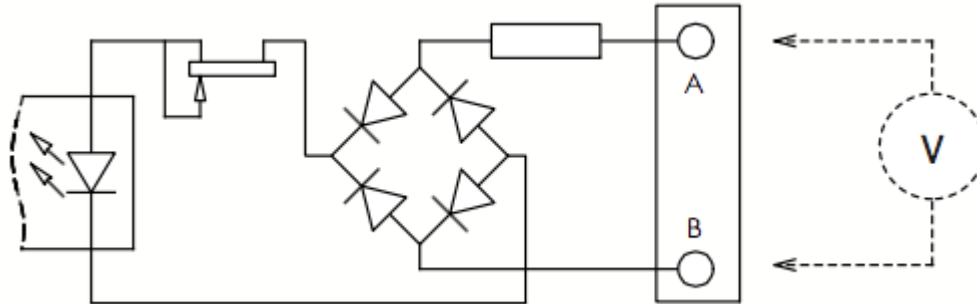

GP Inputs / Outputs			
Connector Type:		25-way D-type male	
Pin	Description	Notes:	
1	Input 1A	See input requirements above	
14	Input 1B		
2	Input 2A		
15	Input 2B		
3	Input 3A		
16	Input 3B		
4	Input 4A		
17	Input 4B		
5			
18			
6			
19			
7	+12 V Output		0.5 A max (both pins), Linked to pin 13 Reference for 12 V output
20	Chassis		
8	Output 1A		See contact ratings above
21	Output 1B		
9	Output 2A		
22	Output 2B		
10	Output 3A		
23	Output 3B		
11	Output 4A		
24	Output 4B		
12			
25			
13	+12 V Output	As pin 7	

## **Appendix E – Safety Notices**

### *General Safety*

1. Please read and keep this document.
2. Adhere to all warnings and follow instructions.
3. This electrical equipment should not be used near water.
4. Cleaning should only be with dry cloths or products compatible with electrical devices – never when the unit is powered.
5. Keep the unit free of dust and use in a clean environment.
6. Do not use near any heat source or in direct sunlight.
7. Do not use near naked flames.
8. Do not place heavy objects on the unit.
9. Only use attachments/accessories recommended by the manufacturer.
10. Unplug the device during lightning storms or long periods of nonuse.
11. The unit can only be serviced by qualified personnel – Seek immediate service if:
  - I. The unit has been exposed to moisture
  - II. The unit has been dropped
  - III. The unit does not operate normally
12. Do NOT modify this unit – alterations may affect performance, safety and/or international compliance standards.
13. SSL does not accept liability for damage caused by maintenance, repair or modification by unauthorised personnel.

### *Installation Notes*

1. When installing this apparatus either fix it into a standard 19" rack or place the apparatus on a secure level surface.
2. When this apparatus is rack mounted, fit all rack screws. Rack shelves are recommended for this apparatus.
3. Allow a 1U gap above and below this apparatus for cooling.
4. Do not obstruct any ventilation cut-outs or exhaust fans.
5. Ensure that no strain is placed on any cables connected to this apparatus. Ensure that all such cables are not placed where they can be stepped on, pulled or tripped over.

### Power Safety

1. The unit is not supplied with a mains lead allowing you to use IEC distribution of mains cables of your choice. Any mains cable used must fulfil the following:
  - I. Refer to the ratings label on the rear of the unit and always use suitable mains cords.
  - II. The unit should ALWAYS be earthed with the earth on both IEC sockets (when both are used).
  - III. Please use a compliant 60320 C13 TYPE SOCKET. When connecting to supply outlets ensure that appropriate sized conductors and plugs are used to suit local electrical requirements.
  - IV. Maximum cord length should be 4.5m (15').
  - V. The cord should bear the approval mark of the country in which it is to be used.
2. The appliance coupler is used as the disconnect device, ensure that it is connected to an unobstructed wall outlet.
3. The mains inlets are designed for connection to a single phase AC supply however each inlet can safely be connected to a separate phase of a three phase mains supply. Warning: if connected to separate phases up to 400V potential phase to phase may be present.
4. The clear markings regarding redundant power supplies detailed on the unit must be transferred into the installation to ensure both power sources are removed before qualified personnel service the unit.

**GB** The apparatus shall be connected to mains socket outlets with a protective earthing connection

**DEN** Apparatets stikprop skal tilsluttes en stikkontakt med jord, som giver forbindelse til stikproppens jord

**FIN** Laite on liitettävä suojavaadoituskoskettimilla va rustettuumpistorasiaan

**NOR** Apparatet må tikoples jordet stikkontakt

**SWE** Apparatens skall anslutas till jordat uttag



**ATTENTION!** This equipment must be Earthed. Refer to manual for installation instructions.

**CAUTION!** Disconnect all power sources before removing any panel (s). No user-serviceable parts inside – to be serviced only by qualified personnel.



**WARNING!** Un-Earthed metal parts may be present inside enclosure. Check for hazardous voltages before touching.

For protection against risk of fire – replace only with same type / rating of fuse. Do not expose to rain or moisture.

### For EU



The stagebox is CE compliant and fully conforms with the current protection requirements of the European community council directives on EMC and LVD. Note that any cables supplied with SSL equipment may be fitted with ferrite rings at each end. This is to comply with the current regulations and these ferrites should not be removed. Any modifications to this equipment may adversely affect the CE compliance of this product.



## Environmental Declaration



The symbol shown here, which is on the product or its packaging, indicates that this product must not be disposed of with other waste. Instead, it is the user's responsibility to dispose of their waste using a designated collection point for recycling of waste electrical and electronic equipment. The separate collection and recycling of your waste equipment at the time of disposal will help to conserve natural resources and ensure that it is recycled in a manner that protects human health and the environment. For more information about where you can dispose of your waste equipment for recycling, please contact your local city office, your household waste disposal service or where you purchased the product.

## RoHS Notice

Solid State Logic has conformed and this product has conformed to European Union's Directive 2011/65/EU on Restrictions of Hazardous Substances (RoHS) as well as the following sections of California law which refer to RoHS, namely sections 25214.10, 25214.10.2, and 58012, Health and Safety Code; Section 42475.2, Public Resources Code.

## For USA

To the User:

1. Do not modify this unit! This product, when installed as indicated in the instructions contained in the installation manual, meets FCC requirements.
2. Important: This product satisfies FCC regulations when high quality shielded cables are used to connect with other equipment. Failure to use high quality shielded cables or to follow the installation instructions may cause magnetic interference with appliances such as radios and televisions and will void your FCC authorisation to use this product in the USA.
3. Note: This equipment has been tested and found to comply with the limits for a Class A digital device, pursuant to part 15 of the FCC Rules. These limits are designed to provide reasonable protection against harmful interference when the equipment is operated in a commercial environment. This equipment generates, uses, and can radiate radio frequency energy and, if not installed and used in accordance with the instruction manual, may cause harmful interference to radio communications. Operation of this equipment in a residential area is likely to cause harmful interference in which case the user will be required to correct the interference at his own expense.

## Electromagnetic Compatibility

EN55103-1:2009, EN55103-2:2009 Environments E1, E2, E3 and E4

Initial inrush current: 0.5 A, 5 sec inrush current: 0.5 A

To maintain electromagnetic compatibility SSL recommends using shielded and foiled twisted pair Ethernet cables of Cat 5e standard or above where applicable.

## Environmental

<b>Temperature</b>	Operating: +5 to 40 °C	Storage: -20 to 50 °C
	<b>Relative Humidity</b>	Operating: 20 to 80 % humidity Max. wet bulb: 29 °C (non-condensing)
<b>Vibration</b>	Operating: < 0.2 G (3-100 Hz)	Non-operating: < 0.4 G (3-100 Hz)
<b>Shock</b>	Operating: < 2 G (10 ms max.)	Non-operating: < 10 G (10 ms max.)
<b>Altitude</b>	Operating: 0 to 3000 m (above sea level)	Non-operating: 0 to 12000 m