

# *Duality Fuse*

## **Operator's Manual**

# Solid State Logic®

Visit SSL at:

[www.solidstatelogic.com](http://www.solidstatelogic.com)

© Solid State Logic

All rights reserved under International and Pan-American Copyright Conventions

SSL® and Solid State Logic® are ® registered trademarks of Solid State Logic.

Duality Fuse™, VHD™, Fusion™, delta™, delta-Ctrl™ and SuperAnalogue™ are a trademark of Solid State Logic.

All other product names and trademarks are the property of their respective owners and are hereby acknowledged.

No part of this publication may be reproduced in any form or by any means, whether mechanical or electronic, without the written permission of Solid State Logic, Oxford, OX5 1RU, England.

As research and development is a continual process, Solid State Logic reserves the right to change the features and specifications described herein without notice or obligation.

Solid State Logic cannot be held responsible for any loss or damage arising directly or indirectly from any error or omission in this manual.

PLEASE READ ALL INSTRUCTIONS, PAY SPECIAL HEED TO SAFETY WARNINGS.

E&OE

March 2026

## Document History

82BDYP01A	Feb 2013	Initial release – updated for V3
82BDYP01B	Mar 2015	Duality delta update
82BDYP01C	Nov 2016	Automation image corrected
82BDYP01D	Sep 2018	Updated Nuendo/Cubase control layout
82BDYP01E	May 2019	
82BDYP01F	Nov 2020	Duality Fuse update
82BDYP01G	Aug 2021	Remove erroneous AU delta plug-in references
82BDYP01H	Mar 2026	Remove erroneous delta automation Coalesce description

# Manual CONTENTS

## Section 1: Introduction

<b>Section Contents</b> .....	<b>.1-i</b>
<b>What is Duality Fuse?</b> .....	<b>.1-1</b>
Design Concepts .....	1-1
Key Features Summary .....	1-1
Console Feature Summary .....	1-1
Exceptional Signal Processing .....	1-1
Creative Versatility .....	1-2
DAW Controller .....	1-2
Controller Features Summary .....	1-2
System Options .....	1-2
<b>About this manual</b> .....	<b>.1-3</b>
Conventions Used .....	1-3
Contacting Solid State Logic .....	1-3

## Section 2: Console Operations

<b>Section Contents</b> .....	<b>.2-iii</b>
<b>Section Index</b> .....	<b>.2-v</b>
<b>Overview</b> .....	<b>.2-1</b>
An Introduction to Split Mode .....	2-2
Routing and Signal Flow .....	2-2
DAW I/O Labelling .....	2-2
<b>Channel Strip</b> .....	<b>.2-3</b>
Introduction .....	2-3
Channel Input Section .....	2-4
Dynamics Section .....	2-5
Filters .....	2-7
Equaliser .....	2-7
Insert .....	2-7
Channel Output (CHOP) .....	2-8
Signal Processor Routing .....	2-8
Channel Sends .....	2-9
Channel Pan .....	2-10
D-pot and DAW Control .....	2-11
Channel Cut and Solo .....	2-11
Channel Fader .....	2-11
Master Channel Fader and Mute .....	2-12
Fader Grouping .....	2-12
Fader Links .....	2-13
The Channel TFT Screen .....	2-15

<b>The Centre Section</b> .....	<b>2-17</b>
Introduction .....	2-17
Power Supply Indicators .....	2-17
Central Routing Panel .....	2-18
Main Output Functions .....	2-20
Main Bus Compressor .....	2-21
Master Fader .....	2-22
Track Bus Master Controls .....	2-22
Monitoring .....	2-23
Cue/FX Send Master Controls .....	2-32
Foldback and Headphone Outputs .....	2-32
Stereo Return Channels .....	2-33
Misc Options .....	2-34
Communications .....	2-35
Oscillator .....	2-37
Mix Reassign Matrix .....	2-38
Group Control Faders .....	2-39
Centre Section Metering .....	2-40
Setup Menu .....	2-42

## Section 3: DAW Control

<b>Section Contents</b> .....	<b>3-i</b>
<b>Section Index</b> .....	<b>3-iii</b>
<b>Introduction</b> .....	<b>3-1</b>
DAW Controller Features Summary .....	3-1
Console Focus .....	3-2
DAW Layers .....	3-3
<b>Connecting Duality to DAWs</b> .....	<b>3-5</b>
Connecting via physical MIDI ports .....	3-6
Connecting via ipMIDI .....	3-7
<b>DAW Control Operations</b> .....	<b>3-13</b>
D-pots .....	3-13
<b>The Master Control Panel (HUI Mode)</b> .....	<b>3-15</b>
Channel Banking Controls .....	3-15
DAW Window Buttons .....	3-15
DAW Utility Buttons .....	3-16
Modifier Buttons) .....	3-16
The Default Button .....	3-17
<b>Channel Functions</b> .....	<b>3-19</b>
DAW Meters .....	3-19
Channel Fader .....	3-19
Channel Solo and Cut Panels .....	3-20

Channel SEL Button — Record Ready/Edit/Select .....	3-21
Edit Mode .....	3-21
Select Mode .....	3-22
Working with the Channel D-pots .....	3-22
<b>Input, Output and Send Routing .....</b>	<b>3-25</b>
Viewing Input, Output and Send Routing .....	3-25
Setting input, Output and Send Routing .....	3-25
<b>Motion Control .....</b>	<b>3-27</b>
Basic Transport Controls .....	3-27
Additional Transport Controls .....	3-27
Other useful transport modes .....	3-28
Setting Pre and Post Roll .....	3-28
Setting start (In) and end (Out) Times .....	3-28
Audition .....	3-28
Footswitch Control .....	3-29
Zoom, Navigation and Selection Modes .....	3-29
Scrolling Within a Window .....	3-30
Shuttle/Scrub Wheel .....	3-30
Numeric Keypad .....	3-31
<b>Plug-In Editor .....</b>	<b>3-33</b>
Plug-In Editor Display .....	3-33
Plug-In Editor Controls .....	3-33
Paging Buttons .....	3-33
Selecting a DAW Channel for Plug-In Control .....	3-34
Timecode/Bars & Beats/Samples Display .....	3-34
Plug-In Display Modes .....	3-34
Viewing Current Inserts (Insert Mode) .....	3-34
Assigning a Plug-In or Hardware I/O Insert (Assign Mode) .....	3-35
Editing Plug-In Parameters (Parameter Mode) .....	3-35
<b>Soft Keys .....</b>	<b>3-37</b>
Automation Enables .....	3-37
Automation Modes .....	3-37
Edit Tools Menu .....	3-38
Edit Modes Menu .....	3-38
Status/Group Menu .....	3-38
Function Keys .....	3-39
EDIT Menu .....	3-39
SSL Menu .....	3-39
<b>Working with DAW Automation .....</b>	<b>3-41</b>
Automation Enables .....	3-41
Automation Modes .....	3-41
TRIM Mode .....	3-41
Automation Status Display .....	3-42
Suspending Automation .....	3-42

- Writing Automation (Write to Start, End or All) ..... 3-42
- Automating Cuts ..... 3-43
- Automating Pans and Sends ..... 3-43
- Automating Plug-Ins ..... 3-43
- Mackie Control (MCU) Emulation ..... 3-45**
- Mackie Control Emulation Advantages ..... 3-45
- Implementation ..... 3-45
- Mackie Function Control Overview ..... 3-47
- The Logic Template ..... 3-48
- Nuendo/Cubase Template ..... 3-50
- The Sonar Template ..... 3-53
- Digital Performer Template ..... 3-55

## Section 4: Total Recall

- Section Contents ..... 4-i**
- Section Index ..... 4-iii**
- Overview ..... 4-1**
- Total Recall and Projects ..... 4-2**
- Working with Projects and Titles ..... 4-3
- Saving a TR Setup ..... 4-3
- Recalling a TR Setup ..... 4-4
- Deleting a TR Setup ..... 4-4
- Renaming TR Setups ..... 4-4
- Total Recall Displays ..... 4-5**
- Resetting Controls ..... 4-6**
- Automatically Reset Controls ..... 4-6
- Manually Reset Controls and Auto-Scan ..... 4-6
- Copying and Swapping Settings ..... 4-6**
- Total Recall in the Duality Remote ..... 4-7**

## Section 5: Automation

- Δ-Control Automation ..... 5-1**
- Overview ..... 5-1
- The Δ-Ctrl Advantage ..... 5-1
- Console Basics ..... 5-2
- Δ-Ctrl basics ..... 5-3
- The Δ-Ctrl GUI ..... 5-4
- Mix Setup Workflow ..... 5-5
- Mixing with Δ-ctrl ..... 5-6**
- Mix Set Up ..... 5-6

Writing Fader Mix data .....	5-6
<b>Updating Fader Mix Data .....</b>	<b>5-7</b>
Fader Links .....	5-9
Switch Automation .....	5-9
<b>MOTORS OFF .....</b>	<b>5-10</b>
<b>Using the Pro Tools Editing Tools .....</b>	<b>5-11</b>
Write to Start, End or All .....	5-11
<b>Legacy Console Automation .....</b>	<b>5-13</b>
Overview .....	5-13
Key features .....	5-13
<b>Automation and Projects .....</b>	<b>5-14</b>
Working with Projects and Titles .....	5-14
<b>Automation in the Duality Remote .....</b>	<b>5-15</b>
<b>Operation .....</b>	<b>5-16</b>
Activating the Automation System .....	5-16
List Mix Menu .....	5-16
Creating A New Mix Pass .....	5-16
Mix Running .....	5-17
Join and Revise .....	5-19
Discard .....	5-20
Updating a Mix Pass .....	5-20
Protection Modes .....	5-20
Switch Automation .....	5-21
<b>Automation Options .....</b>	<b>5-22</b>
Trim .....	5-22
Trim Lok .....	5-23
Motors Off .....	5-23
Snap Mode .....	5-24
AutoTakeover .....	5-24
Offline Trim .....	5-24
Copy and Swap .....	5-25
Saving Mix Passes to your DAW Project .....	5-25
Automation Setup Options .....	5-25

## Section 6: Remote Browser

<b>Installing the Application.</b> . . . . .	<b>6-1</b>
<b>A Note On Java.</b> . . . . .	<b>6-1</b>
<b>Connecting Duality Fuse to the Computer.</b> . . . . .	<b>6-2</b>
Connecting to Duality Fuse . . . . .	6-2
Project and Title Notes . . . . .	6-3
<b>Managing Projects</b> . . . . .	<b>6-4</b>
Creating a New Project . . . . .	6-4
<b>Project Options Menu</b> . . . . .	<b>6-4</b>
New Title . . . . .	6-4
Duplicate . . . . .	6-4
Rename . . . . .	6-4
Deleting a Project . . . . .	6-4
Backing Up a Project . . . . .	6-4
Restoring a Project . . . . .	6-4
<b>Managing Titles</b> . . . . .	<b>6-5</b>
Creating a Title . . . . .	6-5
<b>Title Options Menu</b> . . . . .	<b>6-5</b>
Opening a Current Title . . . . .	6-5
Duplicating and Copying a Title . . . . .	6-5
Rename . . . . .	6-6
Deleting a Title . . . . .	6-6

## Section 7: Fusion Processing

<b>Fusion processing</b> . . . . .	<b>7-1</b>
Introduction . . . . .	7-1
<b>Processing Section Overview</b> . . . . .	<b>7-3</b>
<b>Signal Flow Overview.</b> . . . . .	<b>7-4</b>
<b>Processing In Detail</b> . . . . .	<b>7-5</b>
O/LOAD (Overload) . . . . .	7-5
Input Trim . . . . .	7-5
HPF (High-Pass Filter) . . . . .	7-5
The 6 Colour Circuits . . . . .	7-6
Vintage Drive . . . . .	7-6
Violet EQ . . . . .	7-8
HF Compressor (High Frequency Compressor) and Stereo LMC (Listen Mic Compressor) . . . . .	7-9
HF Compressor . . . . .	7-9
Stereo LMC (Listen Mic Compressor) . . . . .	7-9
Stereo Image . . . . .	7-9
Transformer . . . . .	7-10
Stereo Insert . . . . .	7-11
Insert (Standard Mode) . . . . .	7-11

Insert (M/S Mode) . . . . .	7-11
Bypass Modes . . . . .	7-11
Bypass (Standard Mode) . . . . .	7-11
Bypass (Post I/P Trim) . . . . .	7-11
Output Trim . . . . .	7-11
Master Meter . . . . .	7-12
Front Panel Switch Haptic Feedback (Button Clicks!) . . . . .	7-12
Precision Image Adjust . . . . .	7-12
Fusion Routing Switch . . . . .	7-12
User Switches . . . . .	7-12
User Switch Mode Programming . . . . .	7-12
<b>Fusion Signal Routing . . . . .</b>	<b>7-13</b>
Patchbay and Signal Routing . . . . .	7-13
Fusion and Mix Bus Inserts . . . . .	7-14
Fusion Signal Flow Examples . . . . .	7-15
Fusion processing routed to MIX A with Bus Compressor AFTER Fusion Processing . . . . .	7-15
Fusion processing routed to MIX A with Bus Compressor BEFORE Fusion Processing . . . . .	7-15
Fusion processing routed to STEREO SUBMIX . . . . .	7-15
Fusion processing - Independant routing . . . . .	7-16
Fusion processing - Independant routing, patching into Mix B (or Mix C) . . . . .	7-16
<b>Settings Mode &amp; Factory Reset . . . . .</b>	<b>7-17</b>
Entering Settings Mode . . . . .	7-17
Meter & Switch Brightness . . . . .	7-17
Relay Feedback . . . . .	7-17
Exiting Settings Mode . . . . .	7-17
Factory Reset . . . . .	7-18
Simon Says Game . . . . .	7-18
<b>Fusion Section - Other Settings . . . . .</b>	<b>7-19</b>
UID Display Mode . . . . .	7-19
Unique ID (UID) . . . . .	7-19
Hardware Revision . . . . .	7-19
Soak Mode . . . . .	7-19
<b>Fusion - Block Diagram . . . . .</b>	<b>7-20</b>
<b>Fusion - Recall Sheet . . . . .</b>	<b>7-21</b>
<b>Appendices . . . . .</b>	<b>A-3</b>
AFADA . . . . .	A-3
Block Diagrams . . . . .	A-4



# *Duality Fuse*

**Operator's Manual**

**SECTION 1:**

**Introduction**

---

*This page is intentionally almost blank.*

---

# Contents

<b>SECTION 1: INTRODUCTION .....</b>	<b>1-1</b>
Introduction .....	1-1
What Is Duality Fuse™? .....	1-1
Design Concepts .....	1-1
Key Features Summary .....	1-1
Console Feature Summary .....	1-1
Exceptional Signal Processing .....	1-1
Creative Versatility .....	1-2
$\delta$ -Ctrl .....	1-2
$\delta$ -Ctrl Features Summary .....	1-2
DAW Controller .....	1-2
Controller Features Summary .....	1-2
iLOK .....	1-3
ABOUT THIS MANUAL .....	1-3
Conventions Used .....	1-3
Contacting Solid State Logic .....	1-3

---

*This page is intentionally almost blank.*

---

---

# SECTION 1: INTRODUCTION

## Introduction

### What Is Duality Fuse™?

Duality Fuse is an innovative combination of super analogue console and DAW controller from Solid State Logic. It draws on years of design experience, and incorporates industry standard features from SSL's range of large format music consoles.

### Design Concepts

Duality Fuse combines technology from SSL's acclaimed music console, the XL 9000 K Series, along with new design concepts which faithfully recreate the overload characteristics of valve circuitry through the use of the new VHD preamp. It retains all of the sonic benefits of SuperAnalogue™ capacitor-free servo coupled circuitry, then adds variable harmonic colouration on a channel by channel basis, contained within a control surface which should be familiar to any recording engineer who has previously used SSL consoles.

### Key Features Summary

- Combined large format SSL console and DAW controller
- Legendary SuperAnalogue™ mic preamps and signal processing
- VHD™ (Variable Harmonic Drive) preamp stage
- Comprehensive monitoring up to 5.1 surround with multiple loudspeaker support
- Integrated Fusion™ Mix Bus Processing
- Direct control of DAW recording, editing and mixing functions from the console surface
- Flexible signal routing enhanced by the channel 'Split' function
- Logictivity Remote browser for session management
- ⌘-Ctrl DAW plug-in

### Console Feature Summary

- Integrated console, signal acquisition, signal processing, studio monitoring, bass management and DAW control • Advanced DAW control through a high resolution integrated TFT screen
- Elegant, ergonomic design with a number of add on options
- Innovative large fader dual-control of both DAW and console input path with follow fader metering

### Exceptional Signal Processing

- Legendary SSL sound quality
- SuperAnalogue™ technology derived from SSL's acclaimed XL 9000 K Series console • VHDTM Input Preamp
- DC Coupled for excellent low frequency response
- Balanced signal paths throughout ensuring maximum dynamic range
- Audio bandwidth exceeding that of 192kHz recorders
- Ultra low-noise dual impedance mic amps
- Channel EQ with twin-curve SSL E and G Series 4-band parametric equalisation
- Channel dynamics sections with gate, expander and compressor/limiter
- 5.1 implementation of SSL's classic mix bus compressor
- Highly flexible signal processing order

## Creative Versatility

- Hex mix bus design configurable as a 5.1 bus or three stereo pairs (A, B, C)
- 5.1, stereo or stereo down-mix main outputs
- 24 track busses
- 2 Stereo Cue plus four Aux busses on all channel modules, with EFX re-assign system to feed track busses and channel output
- Wide range of solo modes including Solo-In-Front
- 4 stereo echo returns with full mix/foldback routing
- Unrivalled studio monitoring section with comprehensive user options
- Hi-visibility channel TFT screens for metering and optional Total Recall displays • 2 main VU meters and phase meter
- Comprehensive bus metering in the centre section

## δ-Ctrl

δ-Ctrl is a native AAX/RTAS/VST/VST3 plug-in allowing users to automate their console, as if it were a DAW Plug-in.

### δ-Ctrl Features Summary

- All fader moves are captured and played with the same accuracy as any other DAW automation parameter – moves are no longer quantised to Timecode frames and subframes.
- True 10-bit fader resolution.
- TCP/IP Network based control protocol – not embedded MIDI messages.
- Console Automation data automatically tracks all DAW audio editing operations.
- DAW editing tools can be used to draw and edit console fader and switch automation data.
- MOTORS OFF mode offers the full non moving-fader SSL VCA style mix experience as preferred by key industry re-mixers.
- New MOTORS OFF, Touch Write mode emulates the SSL G-Series Mix system Immediate Pickup (IP) option.

## DAW Controller

Today's DAWs provide the power and convenience of recording and editing audio, but a keyboard and mouse is not the most intuitive way to access these controls. For most users, finding an integrated solution that answers all of their working needs is strongly desired. Duality Fuse achieves this to an extent and quality that has previously been unavailable.

### Controller Features Summary

- Direct access to all major DAW mixing, editing and automation parameters via HUI and MCU protocols • Direct control of plug-in settings
- Dedicated control processor to maximise console performance
- Integral colour TFT display with dedicated control keys
- High quality motorised faders to write/replay level moves in your DAW • Simple switching between console layer and DAW control layer
- Two independent DAW layers or single Dual DAW layer option
- Full remote control implementation
- Operation independent of platform: works with Pro Tools™, Nuendo™, Logic Audio™, and others
- MIDI over Ethernet for enhanced control of two DAW systems

## iLOK

The plug-in uses the industry standard iLOK copy protection scheme. 5 licences are included as standard. Additional licences will be available from the SSL Web Store.

## ABOUT THIS MANUAL

This manual is divided into six main sections, and is designed to provide a comprehensive source of information for Duality Fuse console users. The table of contents will help you to familiarise yourself with the basic content of each section. If you are reading this from an electronic version of the manual, use the 'bookmark' feature to rapidly locate to virtually any topic.

If you have not previously used an SSL console, you are advised to read the Duality Fuse overview at the start of Section 2. Those of you who have experience of SSL's range of analogue consoles will have little difficulty getting to grips with the operation of this console's control surface; features that are specific to Duality Fuse are fully described in Section 2.

To set-up and configure the software interface between Duality Fuse and your chosen DAW, please study Section 3. This section also covers the DAW functions that you can usefully control from Duality's centre section.

Finally, the last section in this manual is provided to hold useful appendices that you may be supplied with from time to time.

## Conventions Used

Some typographical conventions have been used in this manual to help distinguish explanatory text from the text referring to console items. They are as follows:

- Physical switches and controls on the console are referenced in bold uppercase (eg. **SOLO** or **EQ-IN**).
- Silk screened text on the console's control surface can be either UPPERCASE (eg. DYNAMICS), or lowercase bold (eg. **auto**), or Titlecase (eg. Talkback Mix).
- Any text on the console's TFT screen or DAW menu options are referred to in a ***Bold italic*** typeface.

---

*Items of note or cautions are shown in italic with lines above and underneath.*

---

- Whenever this manual mentions the selection or pressing of a button, it is assumed that the button was not active (ie. not lit), and that this action has made it active (ie. it has become lit).
- Similarly, whenever the manual mentions the deselection of a button (or pressing it again), it is assumed that it was active before the action, and has become inactive due to this action.

## Contacting Solid State Logic

If you cannot find the information you need on the pages of this manual, please refer to the Duality Fuse support pages at [www.solidstatelogic.com](http://www.solidstatelogic.com)

---

*This page is intentionally almost blank.*

---

# *Duality Fuse*

**Operator's Manual**

**SECTION 2**

**Console Operations**

---

*This page is intentionally almost blank.*

---

# Section Contents

Section Contents .....	2-i
Section Index .....	2-iii
Overview .....	2-1
An Introduction to Split Mode .....	2-2
Routing and Signal Flow .....	2-2
DAW I/O Labelling .....	2-2
Channel Strip .....	2-3
Introduction .....	2-3
Channel Input Section .....	2-4
Dynamics Section .....	2-5
Filters .....	2-7
Equaliser .....	2-7
undershoot/overshoot .....	2-7
Insert .....	2-7
Channel Output (CHOP) .....	2-8
Channel Sends .....	2-9
Channel Pan .....	2-10
V-pot and DAW Control .....	2-11
adjacent to .....	2-11
Channel Cut and Solo .....	2-11
Channel Fader .....	2-11
Master Channel Fader and Mute .....	2-12
Fader Grouping .....	2-12
Fader Links .....	2-13
The Channel TFT Screen .....	2-15
The Centre Section .....	2-17
Introduction .....	2-17
Power Supply Indicators .....	2-17
Central Routing Panel .....	2-18
UNDO .....	2-19
Main Output Functions .....	2-20
Main Bus Compressor .....	2-21
Master Fader .....	2-22
Track Bus Master Controls .....	2-22
Monitoring .....	2-23
Cue/FX Send Master Controls .....	2-32
Foldback and Headphone Outputs .....	2-32
Stereo Return Channels .....	2-33
Misc Options .....	2-34

Communications .....	2-35
Oscillator.....	2-37
Mix Reassign Matrix .....	2-38
Group Control Faders .....	2-39
Centre Section Metering .....	2-40
Setup Menu.....	2-42

## Section Index

### A

AFL 2-31

### B

Bass Management 2-26

### C

Central Routing Panel 2-18

Centre Section 2-17

CH (channel) control 2-4

CHAN TO MF 2-12

Channel Input 2-4

Channel Output 2-8

Channel Routing 2-15, 2-18

Channel Sends 2-9

Channel Strip 2-3

Channel TFT Screen 2-15

Communications 2-35

Compressor (Channel) 2-5

Compressor (Main bus) 2-21

Control groups 2-39

Cue Stereo 2-9, 2-32

CUT button 2-11

### D

DAW Control 2-1, 2-3, 2-11

DAW Status Indicators 2-15

DRIVE pot 2-4

DRV IN button 2-4

DYN box 2-5

DYN IN button 2-5

Dynamics 2-5

### E

EDIT indicator 2-15

EFX TO TRK 2-10, 2-19

Equaliser 2-7

Expander 2-5

External Source Selectors 2-24

### F

Fader 2-11, 2-22

Fader Grouping 2-12, 2-39

FILT to INP button 2-4, 2-7

Filters 2-7

Foldback 2-32, 2-35

FX Sends 2-9

### G

Gate 2-5

### H

H/P button 2-33

Headphone outputs 2-33

Hi-Z button 2-4

### I

INPUT FLIP function 2-4, 2-19

Insert 2-7

### K

KEY button 2-6

### L

Labelling (DAW I/O) 2-2

LFE 2-38

LINK button (dynamics) 2-6

### M

Main Output Functions 2-20

Master Fader 2-12, 2-22

Metering 2-15, 2-25, 2-40

Misc Options 2-34

Mix Reassign Matrix 2-38

Monitor Calibration 2-28

Monitor Insert 2-25

Monitor Options 2-26

Monitoring 2-23

### O

Oscillator 2-37

### P

PAD button 2-4

Pan 2-10

PFL 2-31

PK LED 2-5

Power Supply Indicators 2-17

### R

REC indicator 2-15

RED LIGHT 2-35

### S

S/Ch LSTN button 2-6

SEL button 2-11

SEL indicator 2-15

SELECT button (Centre Section) 2-18

select button (fader) 2-18

Setup Menu 2-42

Signal Processing Order 2-15

Signal Processor Routing 2-8

SOLO (Central Routing Panel) 2-12

SOLO button 2-11, 2-23, 2-31

SOLO CLEAR 2-23

SOLO ISOLATE 2-19, 2-31

Solo-In-Front 2-31

SPLIT button 2-8

Split Mode 2-2, 2-8

SRC SEL button 2-8

Stereo Mix Matrix 2-38

Stereo Returns 2-33

### T

Talkback 2-35

TO S/ch button 2-7

Track Bus Master Controls 2-22

### V

V-pot 2-3, 2-11

Variable Harmonic Drive 2-4



---

# Section 2: Console Operations

## Overview

Duality Fuse is an evolutionary combination of analogue console and DAW controller from Solid State Logic. It draws on years of design experience, and incorporates industry standard features from SSL's range of large format music consoles.

Duality Fuse combines technology from SSL's acclaimed music console, the XL 9000 K Series with new design concepts which faithfully recreate the overload characteristics of valve circuitry. It retains all of the sonic benefits of SuperAnalogue™ capacitorless servo coupled circuitry, then adds variable harmonic colouration on a channel by channel basis, contained within a control surface which will be familiar to any recording engineer who has previously used SSL consoles.

The ubiquitous DAW (Digital Audio Workstation) has brought many benefits to audio production, including visual audio editing, integrated digital effects processing and convenient session storage and recall. However, although eminently flexible, DAW's present new challenges of integration within the studio environment today.

Duality Fuse has been carefully designed with these requirements in mind. It addresses all the needs of current DAW production techniques in an integrated, high quality and robust design, coupled with all of the sonic benefits expected from a Solid State Logic console.

SSL's extensive design experience has been utilised to create the ultimate capture path for up to 96 simultaneous inputs into the DAW, where recorded signals can be edited, processed and mixed via Duality Fuse's control surface. The signal paths can then be either summed internally within the DAW or returned to the analogue domain for further processing via Duality Fuse's channel path EQ and dynamics processors, before final summing via the console's balanced analogue mix bus architecture. With a comprehensive 5.1 monitoring section, audio can be auditioned with the highest possible audio integrity.

A high resolution, digitally controlled gain element in each channel allows the motorised faders to be switched to control any DAW that supports the HUI or Mackie Control protocols, while retaining control of the analogue signal path. The faders and their associated channel-based rotary encoders (V-pots) provide direct control of DAW faders, pans, sends, plus input and output routing. The Master Control Panel and Duality Fuse's centre section screen give paged control of all plug-in parameters.

In summary, Duality Fuse is a Complete Studio Solution for modern DAW based production environments.

## An Introduction to Split Mode

The Duality Fuse channel strip is optimised for working in conjunction with a multichannel DAW as the primary recording medium. Instead of retaining the 'in-line' architecture of previous SSL consoles, a new 'Split Mode' mode topology has been introduced which provides the equivalent of in-line operation but without the cost and complexity of separate channel and monitor paths.

In DAW-based productions, there is no longer the fixed track count limitation of conventional analogue or digital tape-based recording. This means that most sources are recorded individually to a track with or without processing as production requirements dictate, but without requiring constant access to a 'channel' fader. The Duality Fuse channel supports two input paths normally designated as the Channel Input and the DAW Monitor Return, with a single Channel Output as the DAW Send. The Split Mode architecture allows the input signal to be 'picked off' the channel path at the input stage, or pre fader, and replaced with the DAW return. The input signal automatically becomes the DAW send and the remaining section of the channel handles the DAW return. Toggling Split Mode on and off is the equivalent of the classic send/return (Group /Tape) monitoring. The console sends can select either the channel fader signal or the channel output signal as a source, offering the choice of zero-latency stereo cue and FX mixes, or post-DAW processed sends.

## Routing and Signal Flow

---

*As you read through the following pages, you may find it useful to refer to the signal flow diagrams in the appendices section at the end of this manual.*

---

In order to understand signal flow through Duality Fuse's various operational modes, first we need to discuss how your DAW I/O unit is connected to the console. To take advantage of the sonic and control environment provided by Duality Fuse, it is recommended that each DAW output is returned individually to a Duality Fuse channel strip.

For details of the physical location of Duality Fuse's inputs and outputs, please refer to the Duality Fuse Installation and Setup Manual.

## DAW I/O Labelling

When using DAW routing with Duality Fuse, it is advisable to take time to sensibly label the inputs, outputs and busses within your DAW. Details on how to do this will be found in the documentation supplied with the DAW. Sensible labelling will make the task of performing routing via Duality Fuse's front panel a simple task, rather than relying on having to decipher long complex names often assigned by default to DAW channels.

For example in a 48 I/O system, simply naming inputs and outputs '1' through '48', and busses 'b1' through 'b48' will allow a simple differentiation between hardware I/O and internal DAW busses when using the console control surface. In some DAW systems, I/O paths can be grouped. In this case label stereo paths in pairs such as '1-2', and sub paths as '1' and '2'.

# Channel Strip

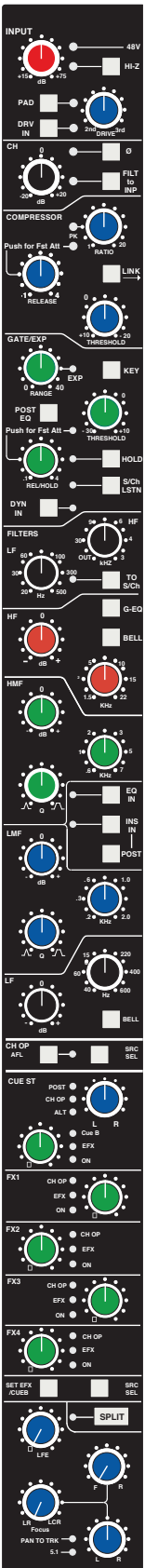

## Introduction

1. Channel Input

Duality Fuse's Split Mode enables the channel processing to be easily applied to channel input signals feeding the DAW record path or to the DAW returns. This provides the equivalent of in-line operation but without the complexity of separate channel and monitor paths.

Users who are familiar with SSL's range of in-line consoles will soon realise that the channel strip faders can control virtual faders on the workstation as well as the channel signal path, in many ways paralleling the large/small fader configuration of an in-line channel strip. This provides an alternative to Split Mode working, with the DAW console handling the functions of a monitor mixer.

2. Dynamics

The channel supports two input connections, the **MONITOR** Input which is normally sourced from the output of the DAW, and the **CHANNEL** input which accepts variable level signals from a microphone, DI box or other audio source. Three preamps are available for use with either input: a unity gain line level buffer which is normally assigned to the DAW return, and a pair of mic preamps sourced from the CHANNEL input XLR connector, one using SSL's Super Analogue direct coupled DC servo circuitry, and the other featuring SSL's proprietary VHD™ (Variable Harmonic Drive) valve emulation gain stage. The channel output can route to 24 Track Busses, any one of three stereo Main Mix Busses (A, B and C) or all the Main Mix Busses in 5.1 mode.

In addition to two Cue Stereo sends and four mono FX Sends, a dedicated Direct Output (CH OP) is provided. Each channel has comprehensive routing for EQ and filter, dynamics, and insert send/return points.

3. EQ and Filter

The channel strip can be divided into five distinct functional sections (see left):

1. 1. Channel input
2. 2. Dynamics
3. 3. EQ and filter
4. 4. Cue Stereo and FX outputs
5. 5. Channel output pan

*Note that a number of channel parameters are adjusted via the Central Routing Panel in the Centre Section, described later in this section. This panel is assigned to a channel by pressing the **SELECT** button at the base of the channel's fader.*

4. Cue + FX Outputs

Beneath the channel strips is a panel containing the 'V-pot' for DAW output or channel level control. This area also houses cut and solo buttons for both fader and V-pot, and an electronic scribble strip. Finally, below the electronic scribble strip, each channel has a long-throw (100mm) moving fader.

5. Channel Output Pan

Above each bay of six channel strips, the TFT meter display provides a large range of useful information on a per-channel basis, including audio and dynamics metering, processing order, bus routing, automation bargraphs (optional) and Total Recall™ (optional).

At your first introduction to the Duality Fuse console, you will immediately see that the channel strip controls are presented in reassuringly familiar manner. The following pages describe each control in detail, with brief coverage of the routing possibilities. See the start of this section for more on signal routing.

---

*In the following descriptions, the connectors referred to are on the rear of each channel module, unless stated otherwise.*

---

### Channel Input Section

This provides two external inputs, the first is a line level DAW return (D-connector), the other (XLR connector), is intended as a mic input but may be used for both mic or line inputs. Normally the Mic Input feeds the variable gain **INPUT** amplifier, and the DAW return feeds a unity gain line amp. However a centrally controlled **INPUT FLIP** function reverses the input routing so that the DAW return can be processed by the variable gain amplifier stage without the necessity for external patching.

The variable gain amplifier features two completely independent preamp stages. Both have electronically balanced inputs with very different but complementary sonic qualities. The default preamp uses SSL's acclaimed Super Analogue circuitry to provide an extremely low noise, extended bandwidth front end with the minimum of signal colouration. Pressing the **DRV IN** button routes the input signal to a completely different preamp featuring the SSL-developed VHD™ (Variable Harmonic Drive) circuitry. VHD emulates the characteristics of a classic valve front end but with the option to tailor the harmonic mix when the preamp is overdriven by adjusting the **DRIVE** pot. In conjunction with the 20dB **PAD** and **HI-Z** input impedance option, VHD can provide subtle valve style warmth to a mic signal or aggressive tonal shaping to existing DAW tracks. However, be aware that, due to differences in the mic amp topology, exact matching of gains is not possible.

---

*Many of the signal routing functions on a channel strip are also available on the central routing panel, and some are only available on the **CENTRAL ROUTING PANEL***

---

The post input stage **CH** (channel) control provides final  $\pm 20$ dB gain trim (for reducing the level when the input section is being abused for creative reasons) and polarity inversion (**Ø**), for the centrally selected channel source. Available input options are the output of the mic input preamp (**MIC**), the balanced line level DAW return (**LINE**), or the channel's associated track bus for patch free subgroups (**BUS**). In the latter case, the channel input is replaced by the output of one of the 24 Track Mix busses where Bus N feeds the input of Channel N, N+24, N+48 etc.

**FILT TO INP** locks the high and low pass filters to the channel source. **+48V** phantom power for mic inputs is selected on the Central Routing Panel.

---

*Selecting **INPUT FLIP** will automatically switch off phantom power in order to prevent damage to the output stage of connected equipment.*

---

## Dynamics Section

The Dynamics section contains a compressor section identical to that of the 9000 K Series and also found in SSL's X-Logic range of outboard processing units. In normal use, the compressor's true RMS, side chain and over-easy soft ratio function provide a very transparent compression action even with large amounts of gain reduction. The fast attack option offers the classic SSL compressor sound normally associated with its use on drum and percussion sources. Selecting Peak (PK) mode defeats the over-easy soft ratio, modifies the release curve and attack times, and unleashes a far more aggressive sounding compressor ideal for more radical sonic shaping.

The Gate/Expander section is a new variant of SSL's classic 4000 series three-control design. It features the choice of a steep gate or gentle expander slope, with optional fast attack. The new 'Hold' (HOLD) option flips the variable release (REL) control to function as a variable hold-off time with a fixed release curve.

The complete section is switched in or out of circuit using the **DYN IN** button (see also **CENTRAL ROUTING CONTROL**). When the dynamics section is in circuit, the **DYN** box on the channel TFT display is highlighted.

Individual controls act as follows:

### Compressor

**RATIO** – When turned to 1:1, the compressor section is inactive. Turning the control clockwise increases the compression ratio until it reaches a true limit mode at the fully clockwise position. Pressing the **RATIO** knob switches the compressor to peak mode, and replaces the 'over easy' characteristic with a hard knee, providing an alternative voicing for some instruments. The **PK** LED lights to indicate that this option has been selected.

**THRESHOLD** – Whenever a signal exceeds the level set by this control, the compressor will start to act at the ratio set by the **RATIO** control. This control, in conjunction with the Ratio setting, provides automatic make-up gain, so as you lower the threshold and introduce more compression, the output level is increased, maintaining a consistent output level.

**RELEASE** – Sets the time constant (speed) with which the compressor returns to normal gain settings once the signal has fallen below the compressor threshold. This control also incorporates a push-push switch which selects a very fast attack time as an alternative to the standard time constant.

### Gate/Expander

This section can act as a Gate or as a 2:1 Expander when the **RANGE** pot is pressed. The **EXP** LED indicates that Expand mode has been selected.

**RANGE** – Determines the depth of gating or expansion. When turned fully anticlockwise (Range = 0), the section is inactive. When turned fully clockwise, an attenuation range of greater than 40dB can be obtained.

**THRESHOLD** – Variable hysteresis is incorporated in the Threshold circuitry. For any given 'open' setting, the Expander/Gate will have a lower 'close' threshold to prevent 'hunting' artifacts. The hysteresis value is automatically increased as the Threshold is lowered. This is very useful in music recording as it allows instruments to decay below the open threshold before gating or expansion takes place.

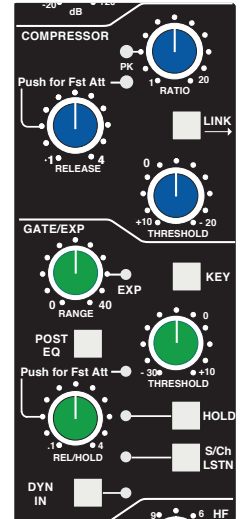

**REL/HOLD** — This determines the time constant (speed), variable from 0.1- 4 seconds, at which the Gate/Expander reduces the signal level once it has passed below the threshold. Note that this control interacts with the Range control. This control also incorporates a switch which, when pushed, provides a fast attack time (100µs per 40db), instead of the normal linear attack time of 1.5ms per 40dB. The attack time is the time taken for the Expander/Gate to ‘recover’ once the signal level is above the threshold. When gating signals with a steep rising edge, such as drums, a slow attack may effectively mask the initial THWACK, so you should be aware of this when selecting the appropriate attack time.

**HOLD** — When this button is pressed, the release time is fixed at 150ms but the hold time can be varied between 0 and 4 seconds by adjusting the **REL/HOLD** pot.

The **LINK** button in the compressor section links the sidechain signal of that unit to the sidechain of the next dynamics section to the right. When two dynamics sections are linked, the control voltages of each section sum together, so that whichever section has the most gain reduction will control the other section.

Don’t try to link two gates using the **LINK** button when you want the signal on one to open the other. If you need to achieve this effect, take a keying signal from one section to trigger the other. The easiest way to do this is by patching from the insert send of the ‘source’ channel into the Key input (see below) of the ‘destination’ channel, and selecting the **KEY** button on this channel.

The **KEY** button feeds whatever signal is present on a channel’s Key input (D-connector) into the sidechain input of that channel’s dynamics section. Pressing **S/CH LSTN** routes the sidechain signal to the console’s PFL bus. This simplifies the set up when either an external key input or the filters to side chain option is in use.

**POST EQ** (not surprisingly) places the dynamics section post the EQ section (see also **CENTRAL DYNAMICS CONTROL** below).

---

*When the dynamics section is not in circuit, its sidechain input is also bypassed.*

---

---

*Signal processing order is graphically displayed on the channel TFT screen*

---

## Central Dynamics Control

The centre section master routing panel replicates the dynamics **POST EQ** function for sweet spot control and multiple channel operation using the **SELECT/TO** range keys.

## Dynamics Section Metering

The TFT screen above each bay of six channel strips is used to display a wide variety of relevant information. In its default Channel mode, as well as channel output metering (see later) a display of dynamics section gain processing is shown, in the form of two columns of indicators — yellow and red for the compressor, green for the gate/expander. See **CHANNEL METERING** for more information.

## Filters

These comprise a 3rd Order 18dB/Octave high pass filter (**LF**) and a 2nd Order 12dB/Octave low-pass filter (**HF**). Each filter is out of circuit when the control is fully anticlockwise. When the filter is in circuit, the **FILTER** box on the channel TFT display is highlighted.

Normally, the filters follow the EQ section in the signal chain but the **FILT TO INP** button in the input section of the channel strip places the filters directly after the channel input. This function is also available on the central routing panel. Pressing **TO S/CH** routes the filter section to the dynamics sidechain.

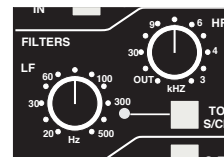

*Signal processing order is graphically displayed on the channel TFT screen*

## Equaliser

This is a four band parametric equaliser based on SSL's classic 'Black Knob' EQ, which was developed for the original SL 4000 E Series console. Selecting the **G-EQ** button introduces steeper shelving curves with a controlled amount of undershoot/overshoot at the turnover frequency, together with the classic gain/bandwidth interaction for the mid band sections that was a key characteristic of the original G-Series EQ.

The individual bands function as follows: **HF** high frequency shelving equaliser switchable to fixed Q parametric (BELL); **HMF** high frequency parametric mid band equaliser; **LMF** low frequency parametric mid band equaliser; **LF** low frequency shelving equaliser switchable to fixed Q parametric (BELL). The **EQ IN** button (located next to the insert buttons) routes the channel signal through the EQ and filter section. When in circuit, the **EQ** box on the channel TFT display is highlighted. See also

### CENTRAL ROUTING CONTROL.

## Insert

The **INS IN** button routes the channel signal via balanced insert send and return points, available on the rear of the console (D-connectors). The insert defaults to the channel input (post the input trim);

**POST** cycles the insert position through two alternative locations in the processing path: post EQ or post Dynamics; the centre section master routing panel provides individual **INS POST EQ** and **INS POST DYN** buttons. When the insert is active, the **INSERT** box on the channel TFT is highlighted.

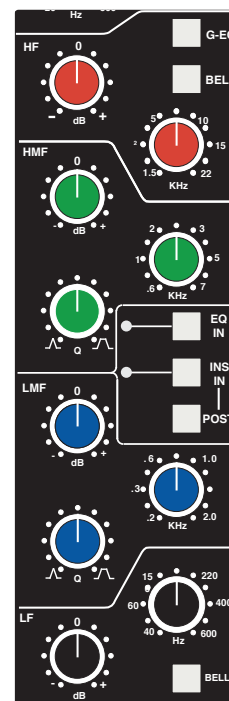
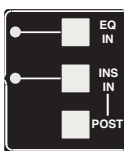

*Signal processing order is graphically displayed on the channel TFT screen*

## Channel Output (CHOP)

The Channel Output (D-connector) is normally used to feed the DAW input. The default signal is a post channel fader feed, but the **SRC SEL** button can be used to select alternative sources: pre channel fader (pre the **SPLIT** point — see below), the channel input (also pre the **SPLIT** point), or an active EFX send (see below). Each selection is graphically displayed on the channel TFT screen (see **CHANNEL METERING** for more information).

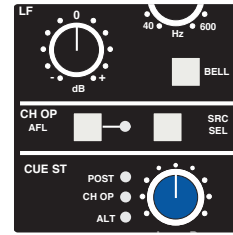

When either the channel input or pre fader source is selected, the **SPLIT** button activates the Split Monitoring function and routes the DAW return into the channel signal path post the split point (see below).

Use the associated **AFL** button to monitor the channel output source as you toggle through the options with the **SRC SEL** button. The central routing panel has single button selection of the four channel output sources: **INPUT**, **PRE FADE**, **POST FADE** and **EFX**.

## Split Mode

When the channel output (DAW input) is sourced from either the channel input or pre the channel fader, the **SPLIT** button (at the top of the panning area for the channel strip) offers a new approach to in-line tracking on an analogue console by returning the DAW output back into the channel path just after the channel output pick off point. By using **INPUT** or **PRE FADE** as the channel output source, clean or processed signals are routed to the DAW input, with the option to use the remaining channel processing and routing to monitor the DAW return in the analogue domain.

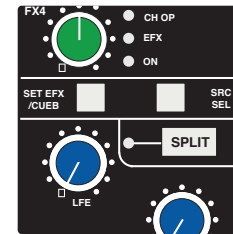

---

*The effect of **SPLIT** is graphically illustrated on the channel TFT (see **CHANNEL METERING** for more information).*

---

---

*Note that **SPLIT** is disabled if **CHOP** is sourced from **POST FADE** or **EFX**, or if the Line Amp is selected as the channel input.*

---

## Channel Sends

Each channel has two stereo and four mono sends that can be used for a number of different purposes: headphone feeds, FX sends, etc. The stereo cues can also be used to provide an additional line input to the mix.

### Cue Stereo

Normally, the stereo cue sources a pre channel fader signal, which routes to the console's Cue A bus. This in turn can be picked up in the centre section and used as a foldback source (see **CUE/ FX MASTER CONTROLS**). Press and hold down the **SRC SEL** button (at the base of the Channel Sends section) then press the stereo cue gain pot to toggle the source through post fader channel feed (**POST**), channel direct output (**CHOP**) or the unused channel input (**ALT**), as indicated by the LEDs adjacent to the stereo cue gain pot.

The **ALT** selection is defined as whichever input is not assigned to the main channel path (when **SPLIT** mode is not active), and allows the stereo cue to be used as an additional input.

When a channel has **BUS** assigned as its input source, the **ALT** input is the main CHANNEL input. This makes it possible to configure channel strips as bus masters, with full processing, and to use the CUE ST level pot as a 'short fader' that controls the level of the ALT source (the MIC preamp), being sent to the track busses via the EFX system. Provided the Channel Output is fed pre fader to the DAW record input, the **SPLIT** monitor mode allows the Bus send to be monitored directly via the Channel fader feeding the main mix busses, or when **SPLIT** is active, to monitor the DAW return.

Likewise, select the stereo cue output to Cue B by holding down the **SET EFX/ CUE B** button then pressing the stereo cue gain pot; this toggles the selection through Cue B, EFX and Cue A (off).

Master controls for the Cue A and B busses can be found in the centre section.

Pan your mono source across the stereo cue bus outputs with the LR pan control. The stereo cue send is turned on/off by means of a push-push switch mounted on the send level control.

### FX Sends

The four mono FX Sends are normally sourced post channel fader. They may, however, be sourced from the channel output (**CHOP**) by pressing and holding down the **SRC SEL** button (at the base of the Channel Sends section) then pressing the required FX gain pot to toggle the selection on/off.

Each FX level pot is fitted with a push-push on/off switch; 'on' is indicated by a LED beside the pot. Master controls for each FX bus can be found in the centre section.

### EFX System

Selecting an FX output to the EFX system (press and hold the **SET EFX/ CUE B** button then press the required FX or Cue Stereo gain pot) allows a single send to be isolated from its associated bus and to be used as source for either the Track Busses (select **EFX TO TRK** on the centre section routing panel), or the channel output — **CHOP** (selected locally or on the centre section routing panel). This enables up to 24 additional independent effects send or headphone mixes to be easily generated. Logic interlocks prevent feedback paths by disallowing the EFX function on a send sourced from the channel output if EFX to channel output is active.

Note that selecting **EFX TO TRK** changes the channel bus routing display from white to green.

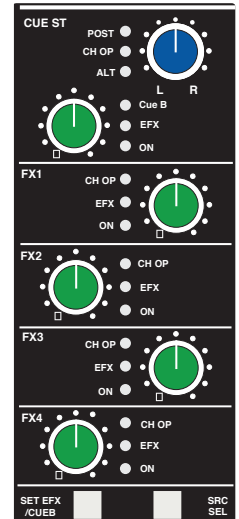

## Channel Pan

At the bottom of the channel strip is a fully featured 5.1 panning section for both the Main Mix busses as well as the 24 Track Busses. With the most complete implementation found on any analogue console, the feature set includes a dedicated LFE send and a fully variable 'Focus' control to alter the phantom/hard centre mix for signals located in the front channels.

The default arrangement is for stereo panning to three pairs of Main Mix busses — A, B and C. The 24 Track Busses normally pick up the mono post fader channel output. On the centre section routing panel, selecting **PAN TO TRK** routes the LR pan outputs to odd/even pairs of Track Busses. Selecting **5.1 PAN** enables the full 6-channel panning options for both the Main Mix busses and the

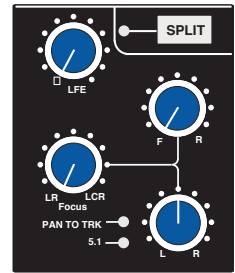

Track Busses, if **PAN TO TRK** is also selected. Local LEDs in each panning section indicate whether that channel has been selected to either of these two modes. When 5.1 panning is not enabled, only the LR (Left/Right) pan control is active.

If the centre section function **EFX TO TRK** is selected, this replaces the normal feed to the Track Busses and defeats 5.1 panning to the busses.

The channel panning section features XY style 5.1 panning via LR (Left/Right) and FR (Front/Rear) controls with additional **LFE** and **FOCUS** functions. The **LFE** control feeds a variable amount of the channel output to a dedicated LFE (subwoofer) bus (see more on this in the **CENTRE SECTION**).

The **FOCUS** control alters the proportion of input signal fed to the front Left/Right busses and the Centre bus, enabling channel signals to be focussed from a 'hard' centre, all the way through to a true phantom centre. As the **FOCUS** knob is rotated clockwise from the LR position, a centrally panned signal is progressively attenuated in the left and right busses, while the gain to the centre channel is increased. When fully clockwise, the LR pan pot becomes a three-channel discrete LCR panner. As the **FOCUS** control is returned to the LR position, variable amounts of divergence are introduced so that, at the 12 o'clock position, signal is present in the three front channels at equal level. As you continue to turn before 12 o'clock, the centre channel is then progressively reduced, leaving only the phantom (Left + Right) centre image at the fully anticlockwise position.

## V-pot and DAW Control

Below the channel strips is a 8-wide panel containing a rotary encoder known as the V-pot, together with its integral momentary switch mounted on the encoder shaft. This is used to adjust the currently assigned DAW parameter or the analogue channel level; V-pot functions are assigned from the centre section, and indicated in the V-pot's associated two line display.

The **CUT** and **SOLO** buttons adjacent to the encoder are used when the encoder is controlling the DAW or Duality Fuse channel gain.

The electronic scribble strip displays the channel name, the name of a DAW track, selected DAW send, or I/O data according to the function currently assigned on the Master Control Panel (see Section 3). When the rotary control and the fader swap roles for gain control, entries in the scribble strip also flip.

The **SEL** button operates the DAW 'Selected Channel' function. This function can be re-assigned from the centre section, to track arm a selected DAW channel or assign the 'plug-in' editor (Pro Tools only). Tallies in the channel meter display Record Ready and Edit status regardless of whether the console is in 'DAW Focus Mode' (see Section 3 for more details).

## Channel Cut and Solo

The **CUT** and **SOLO** switches above the traditional scribble strip function in the normal way, providing muting and solo auditioning of channels.

**SOLO** switches can also be controlled from the master **SOLO** switch, as described over the page.

## Channel Fader

The 100mm moving fader controls the analogue channel, or assigned DAW track, or the DAW send level when the centre section 'flip' function is active (Pro Tools/HUI and MCU interfaced DAWs), plus Plug-In parameters when using a MCU compatible DAW. The required function is selected via the **MASTER CONTROL PANEL** (see Section 3 for details).

Channel faders can also be controlled from the master fader, as described over the page.

The **FADER** button, and associated LEDs are used in conjunction with HUI automation, -Control, legacy Automation as well as Total Recall. (The **PLAY** and **MATCH** buttons are used only with Legacy Automation, not with -Control. See Sections 4 and 5 for more details.)

The **SELECT** button at the foot of the fader is used to select that channel to the Central Routing Panel, and for fader grouping and Master Channel control (see overleaf).



## Master Channel Fader and Mute

The **CHAN TO MF** and **SOLO** buttons in the Central Routing Panel allow analogue channel faders and solos to be controlled from the master fader. The **CHAN TO MF** button is located in the bottom row of buttons in the **CHANNEL SELECT** area, while the master **SOLO** button is located in the **MISC** area in the top right-hand corner of the Panel.

To use the Channel to Master Fader function, scroll to the channel using the **+/-** buttons either side of the channel number display (or the channel **SELECT** button) and activate the **CHAN TO MF** button. The master fader and the Central Routing Panel's **SOLO** button can now be used to control that channel's fader and **SOLO** button.

*These functions are always assigned to the analogue fader's signal, and will follow that signal regardless of the Focus mode and the status of the **CHANNEL** button and fader flip. It is important to understand that you will therefore not always be able to see the changes you are making.*

The Master Channel solo function can also be applied to a range of channels – if a range of channels is selected in the Central Routing Panel, the master **SOLO** button can be used to solo all selected channels.

*Ranges of channel faders cannot be controlled using the Master Fader function. If **CHAN TO MF** is active while a range of channels is selected, the master fader will only operate on the first channel in the range.*

## Fader Grouping

Duality Fuse features traditional VCA style grouping where the sum of the channel (slave) and group (master) fader dB values controls channel gain.

The console's centre section is fitted with eight dedicated group control faders. To assign channel faders to a group, simply press the Fader **SELECT** button of the channel you want to include in the group followed by the **SELECT** button on the required group fader. The group display on each fader will reflect your choice (the fader shown is being controlled by group fader 2). Multiple channels can be assigned to a group using the **TO** function on the central routing panel.

As with previous generation SSL consoles, group faders can be assigned as slaves to other groups to create a hierarchal (nested) grouping structure. To assign a Group fader as a slave to another group, hold the **SELECT** button on the slave group fader followed by the **SELECT** button on the required master group fader.

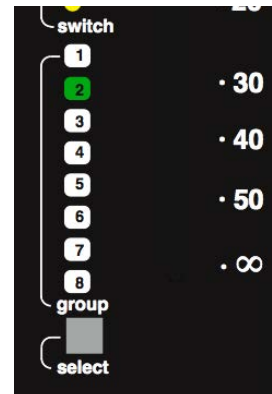

Prior to delta control automation, Duality software had an additional grouping mode termed Servo Grouping. This emulated the grouping function of early moving fader automation systems where the fader itself was the channel gain element. With Servo Grouping, touching a slave fader immediately isolates the channel from following the Group Master position, preventing any group moves from affecting the channel gain. When the slave fader is released, the channel returns to tracking the group fader level but relative to any change in position of the channel fader. Servo Grouping is still available with Duality Fuse but only if Legacy Automation has been enabled.

*Legacy Automation can be enabled via the **SSL / MISC / SETUP** menu – see Section 5-11 for more details. This requires a console restart. Following the restart, an additional menu entry to select the fader grouping mode will be available plus an additional entry to set the Servo Group Lockout Level.*

## Fader Links

Fader Links are a useful method of ganging channels without the complexity of a Master/Slave style grouping system. With a Fader Link, any fader or non-latching switch operation can be applied to all the channels in the link.

Faders retain any existing level offsets, provided no fader in the link reaches the upper or lower extremes of the fader scale. If any member of a link reaches the end of its physical travel, no member of the link can move beyond this point. To access Fader Links, press the **LNKS** soft key next to the **AUTO** key.

### Creating a New Link



To set up a new link, scroll to **NEW LINK** and press the V-pot push switch. This will create a new entry in the list suffixed with a number. This entry will be automatically highlighted, and faders can be added to (or removed from) the link by pressing their **FADER** status buttons (shown on the following page). Link numbers are shown in the fader scribble strip and the red fader status LEDs will indicate those faders in the currently selected link.

While the Fader and **CUT** and **SOLO** switches are always included in Fader Linking, it is possible to exclude the remaining automated channel switches (Cue and FX on, Insert In, EQ In) from the Link: with a fader link highlighted in the **LNKS** page, press the **CHSWS** softkey. When switches are included in the Link, **SWITCHES LINKED** is displayed after the fader link name on the screen (as shown for Link 2 above).

To adjust balance of a link, hold one fader whilst moving another. This automatically isolates the second fader from the link whilst the remaining faders continue to track the first fader touched.

When the Links page is not active, pressing the **SHOW LINKS** button to the left of the Eyeconix button causes the Links to be displayed in the Scribble Strip.

---

*The **SHOW LINKS** button is automatically selected when the Links page is active.*

---

As far as the automation system is concerned (see Section 5), switch and fader operations performed in one channel will cause that function in every channel in the link to go into Write. Links can be dissolved at any time, but all the automation data will still play out correctly.

To edit any existing links, scroll to and select the link. Channels can be added or removed as described above.

### SuspdSel/SuspdAll

Links can be globally or individually suspended at anytime. A link that is suspended will allow you to move all the faders in the link independently. If a link is highlighted, then the **SUSPDSEL** key will deactivate the selected link and 'suspended' will be shown next to the link number. **SUSPDALL** suspends all links in the list. The 'Motors Off' function automatically activates the **SUSPDALL** function.

### Inverting Switch Links

To invert the state of any switch in a link suspend the link, press the switch to toggle it to the opposite state, then re-enable the link.

### Deleting Links

To delete a link, select and highlight it, then use the **DELETE** and **CONFIRM** keys.

Fader Status Button

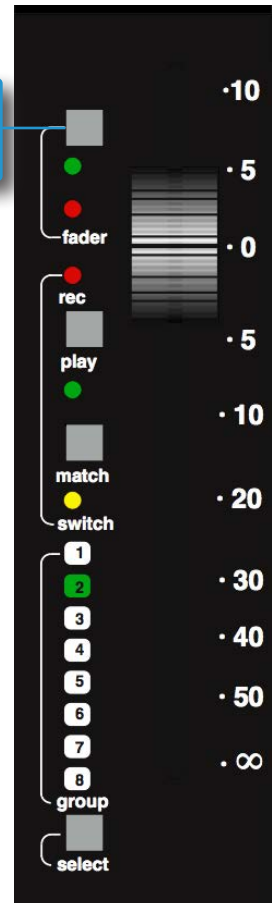

## The Channel TFT Screen

The TFT screen fitted above each channel bay is normally used to display a number of channel related parameters for the six channels in that bay.

When Total Recall is in use, the screen flips automatically to display the control positions for a single, selectable, channel (see Section 4 for more details).

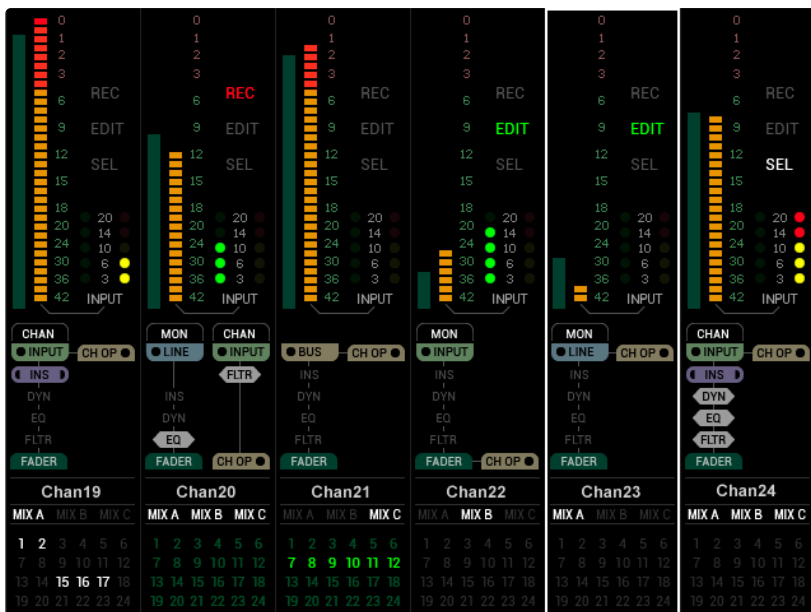

## Channel Routing

At the bottom of the channel display a clear indication is provided of each channel's routing to Main Mix busses A, B and C and the 24 Track busses.

## Signal Processing Order

The section above the routing indicators displays the order of channel processing for both signal paths in each channel (including the channel inputs, the channel fader and the channel output) as well as providing an indication of which processing element is actually in circuit. Once again, colour coding is used for ease of recognition.

## Channel Metering

A single peak meter indicates either analogue channel signals or DAW levels, according to selection of the Console/DAW 'Focus' button (see Section 3 for more on this). The standard scale is +24dB for 0dBFS (top of the scale). Other reference levels (+18dBu, +20dBu, +22dBu) can be selected in the **SSL / MISC / SETUP** menu. A peak hold option is available for channel and centre section meters via the centre section **METERS** setup menu. A legend below the Dynamics section indicators (see below) confirms the currently selected meter point for that channel, as set on the central routing.

In addition to the expected channel metering, two columns of five 'LEDs' give an indication of channel gate/expander gain reduction (green 'LEDs') and compressor gain reduction (yellow and red 'LEDs').

## DAW Status Indicators

To the right of each channel meter are three indicators that provide feedback of the current DAW status of that channel. **SEL** confirms that channel is currently the 'selected channel'. **REC** indicates the Record Ready status of the associated DAW track, and **EDIT** shows if the DAW channel associated with that channel strip is currently assigned to the plug-in editor (Pro Tools only). See Section 3 for more details. Note that Record Ready and Edit status will be indicated regardless of whether the console is in 'DAW Focus Mode' or not.

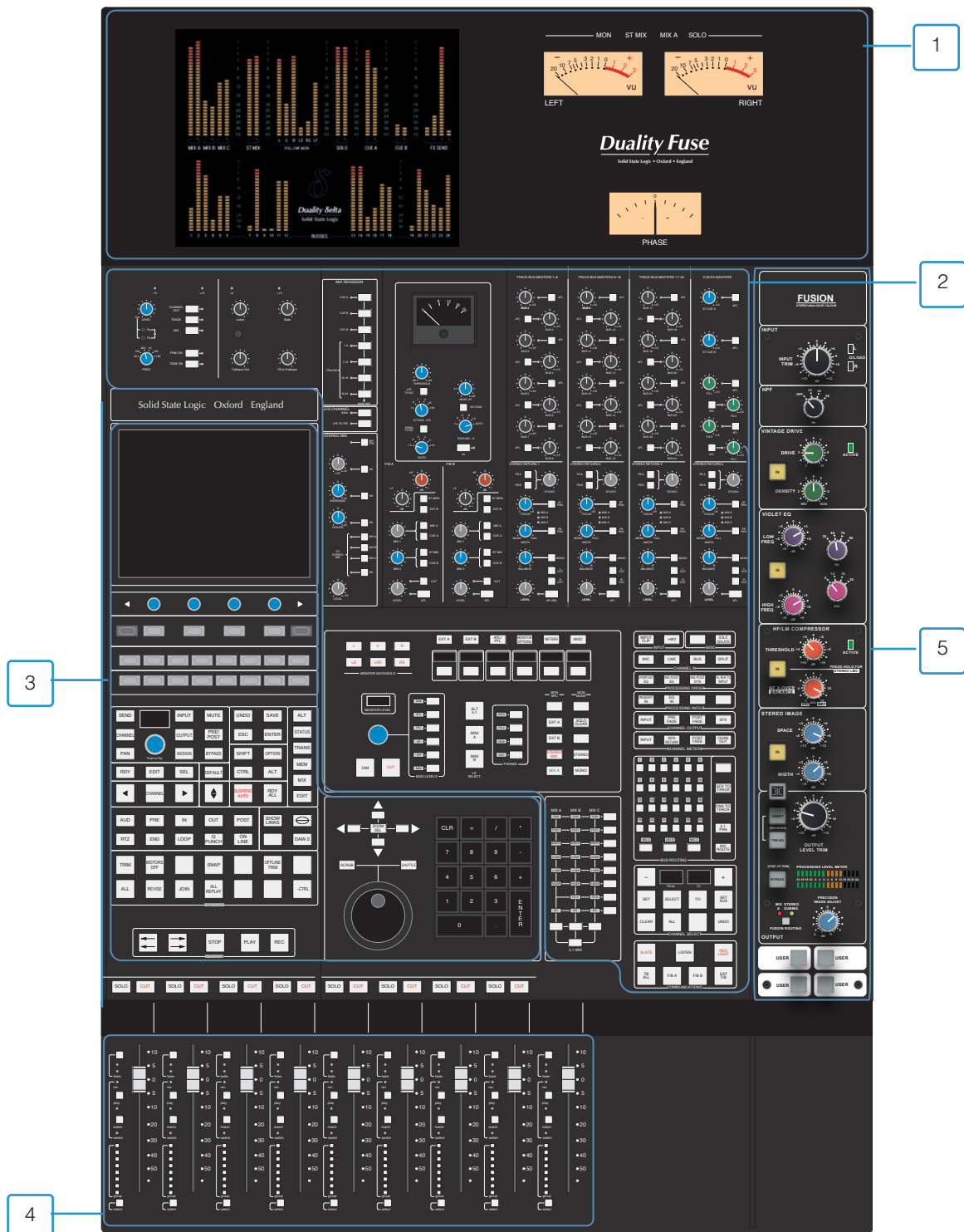

## The Centre Section

### Introduction

The console's centre section (see opposite) comprises five main areas:

1. Centre section meter panel.
2. Audio master control functions.
3. TFT screen and panels dedicated to DAW control; automation controls; DAW transport controls.
4. Group faders and master fader.
5. Fusion Processing Section and User Switches/Indicators

Once you have spent a few moments sitting at the console, you will find the Duality Fuse's centre section layout just as intuitive as its channel strip.

The following pages cover all the analogue controls in the centre section. See Section 3 for details of the console's DAW control facilities.

### Power Supply Indicators

Before we cover the more interesting features of the centre section, take a moment to acquaint yourself with the console's power supply indicators. If you suspect a hardware problem, and one of the LEDs described below is not lit, there may be a power supply fault. The LEDs, which display the current state of power rails within the console, are in the top left hand corner of the centre section, above the oscillator and talkback level controls.

The  $\pm 15$  Volt and the +4 Volt supplies are for analogue audio and logic circuitry respectively. The +12 Volt supply provides power for the faders and some relays. All LEDs should normally be illuminated, if not – try not to panic!

## Central Routing Panel

In addition to the DAW transport controls and the console monitor pot, in day- to-day operation you will probably find you use this panel more than any other, so it's worth taking a few minutes to fully understand its capabilities.

This panel provides access to channel routing, signal processing order, and other facilities, on single or multiple channels. Channels can be selected in a contiguous range or randomly across the console.

Channels are selected to the panel by pressing the **SELECT** button at the foot of each channel fader. The channel TFT meter will be outlined in green to indicate the selected channel.

Normally the routing panel is 'off' — ie all displays are blank. Pressing any channel **SELECT** button, or the + and – buttons (on the panel) together, wakes the panel up with a single channel selected — this will be either the **SELECT** button channel or the first channel of the previous selection.

Single channels can be selected at any time by pressing the channel **SELECT** buttons or using the +/- buttons. The currently selected channel will be shown in the left hand ('FROM') window. The right hand display will be blank.

To select a range of channels, press the **TO** button when a **FROM** channel has been selected. Initially, the next consecutive channel will be displayed in the right hand **TO** window and indicated on the channel meter display. To increment the range either use the +/- buttons, or press a second channel **SELECT** button to select the highest channel in the range; the highest channel is shown in the **TO** window.

Once a channel has been selected, The Central Routing Panel's **SELECT** button allows non contiguous arrays of channels to be added or removed from the current selection. The **SELECT** button will flash when active and any channel can added or removed from the current selection via the **SELECT** button on its fader. If **SELECT** is active the **ALL** button can be used to select all the console channels.

To deactivate the routing panel, press the + and – buttons simultaneously, or re-press the channel **SELECT** button on the active channel, (if **SELECT** or **TO** are not active).

Once a channel or range of channels has been selected, selections and changes made on the routing panel are made across all selected channels. If some functions are on and some are off on the selected channels, the lowest numbered channel in the selection sets the initial state. For example, you select channels 3 to 6. If channel 3 is assigned to a bus, then the first press on that bus routing button will deroute channels 3 to 6 from that bus.

If channel 3 is not assigned to a bus, then the first press on that bus routing button will route channels 3 to 6 to that bus.

The **CHAN TO MF** button assigns control of the fader and **SOLO** switch for the selected channel, as explained in the *Master Channel Fader and Mute* in the previous section of this chapter.

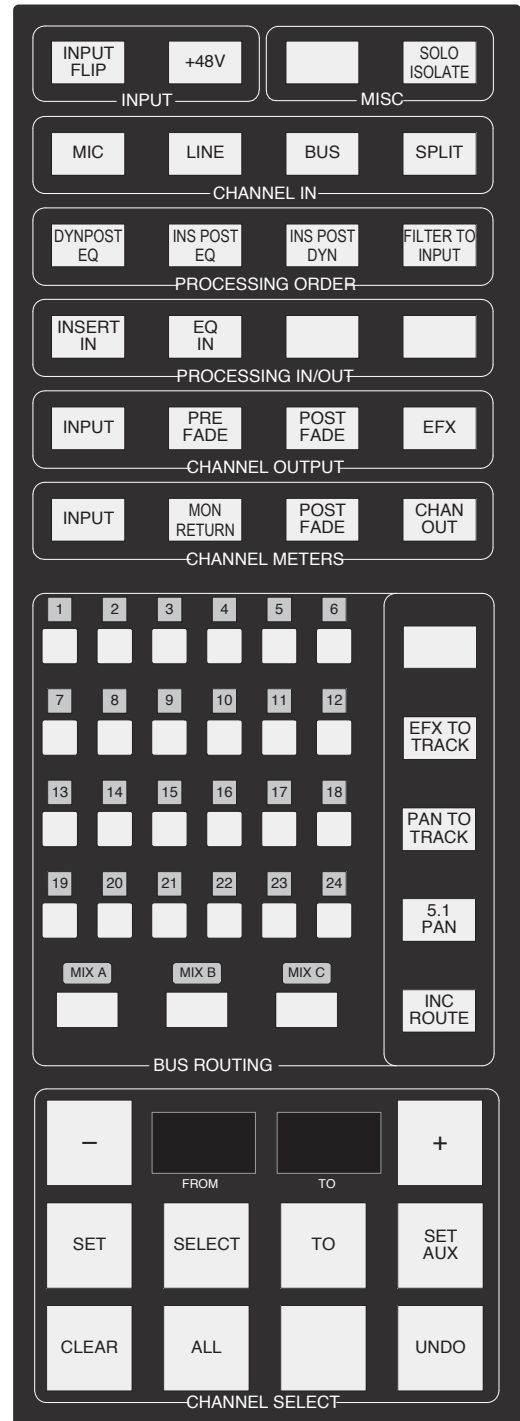

Having selected a channel, or range of channels, all the functions in the area above can be selected/deselected. Routing buttons **1-24** and **MIX A, MIX B, MIX C**, are self explanatory, as should most of the buttons above. Note that changes made to the 'PROCESSING ORDER' are graphically indicated on the channel TFT displays.

Items that may not be immediately obvious are as follows:

**+48V** – phantom power is selected here, as is **INPUT FLIP** and the channel input source – **CHANNEL IN**.

---

*Selecting **INPUT FLIP** will automatically switch off phantom power.*

---

**SOLO** – Duplicates the **SOLO** switch for the currently selected channel, when **CHAN TO MF** is selected (see *Master Channel Fader and Mute* in the previous section of this chapter for more details).

**SOLO ISOLATE** – Solo isolated channels will not be cut when other channels are soloed. Useful for FX returns.

---

*Solo-isolated channels can be set to automatically solo in AFL mode via the **ISOLATED CHANNELS AFL ON SOLO**: option in the **SSL / MISC / SETUP** menu.*

---

---

*The **ISO** button in the **AFL/PFL** menu allows a number of Solo Isolates to be set more easily, as described below.*

---

In the '**PAN MODE**' section, **INC ROUTE** works in conjunction with the channel **SELECT** and **TO** functions, and provides incremental bus routing for a range of channels. The selected channels will be incrementally routed (or derouted if currently assigned) to consecutive busses starting from the first bus selected. **5.1 PAN** enables 5.1 panning mode. **PAN TO TRK** routes the output of the selected channel's pan to the Track busses. Stereo panning is between odd/even pairs; 5.1 panning divides the track busses into four 6-channel groups. **EFX TO TRK** replaces the channel feed to the Track busses with the active EFX send output. Stereo Cue EFX sends are automatically routed to odd/ even pairs.

When **SET AUX** is selected, changes made to Cue Stereo and FX source and destination routing and On/Off state, on any of the selected channels, will be copied to all selected channels, allowing the quick set up of aux sends. Again, if some functions are on and some are off on the selected channels, the lowest numbered channel in the selection sets the initial state.

**SET** and **CLEAR** provide an alternative way to set up routing. Press either **SET** or **CLEAR**, then select the function(s) you wish to turn on or off. Pressing the **SELECT** button on any channel will set or clear the selected function(s).

Pressing **ALL** when **SET** or **CLEAR** are selected will make the **SET** or **CLEAR** button flash. A second press on **SET** or **CLEAR** will make the assignment/de-assignment across all channels.

**UNDO** undoes all routing and channel set up changes since the routing panel was last made active. As a safety measure, it requires two presses in quick succession to carry out the undo operation. The UNDO operation automatically deselects the routing panel.

## Main Output Functions

Duality Fuse features a 6-wide main mix bus that can be configured either to provide a full 5.1 surround mix or three stereo mix busses.

The six main mix busses are represented by three columns of indicators on this panel which, in turn, represent three independent stereo pairs, **MIX A, MIX B AND MIX C**. Functions are assigned to these busses using the dedicated row keys on the right of the matrix, in conjunction with the mix select keys at the base of the matrix columns.

Each pair of busses has a switchable **INSERT** point with the option to be placed pre (default) or **POST** the main output level control (normally the master fader).

So, for example, lets assume all your channels are routed to **MIX A**, and you want to insert an external stereo compressor on that bus. Press and hold the button at the foot of the **MIX A** column and then press the button to the right of the **INSERT** row; the associated **INSERT** indicator will light. Additional facilities described below are assigned in a similar manner.

In Duality Fuse the **MIX A** Insert can be automatically fed through the FUSION processing if the FUSION ROUTING switch at the bottom of the Fusion Section is switched to MIX A.



*The FUSION ROUTING is via the Patchbay, so for this to operate correctly no Patch Cords should be 'over patched' on the Patchbay,*

**SUM** mode allows the insert return to be summed with the main signal path. **COMP**

assigns the master on-board compressor to the selected bus(es). This functions as single stereo unit inserted on a chosen stereo bus or as a 5.1 compressor when in 5.1 mode (see below). The single master **FADER** is assigned to individual stereo mix stems or as a 5.1 master fader in 5.1 mode. The fader can control the same level of all three stereo busses simultaneously but can only set the level for one bus at a time. If not fader-controlled, the main output level will be set at the last set level. Maximum gain is 0dB or +10dB if the **+10dB** function is selected. This again can be set either on individual stereo busses or globally for 5.1 mixes.

The **TO A** function for **MIX B** and **MIX C** enable those busses to be folded down and added to **MIX A**. The output of each stereo mix bus can be individually monitored (confidence-checked) by selecting the **AFL** function.

All the above assumes you are working in 'stereo' mode. If you select the **5.1 MIX** button at the foot of the matrix, the **MIX A, B** and **C** assignment buttons function as a group. For example, if you select the **COMP** (compressor,) it will be automatically assigned to all six busses (as indicated by the matrix **COMP** indicators). Selecting the 5.1 MIX button puts the matrix into 5.1 mode regardless of the state of the **5.1 PAN** button on the **CENTRAL ROUTING PANEL**.

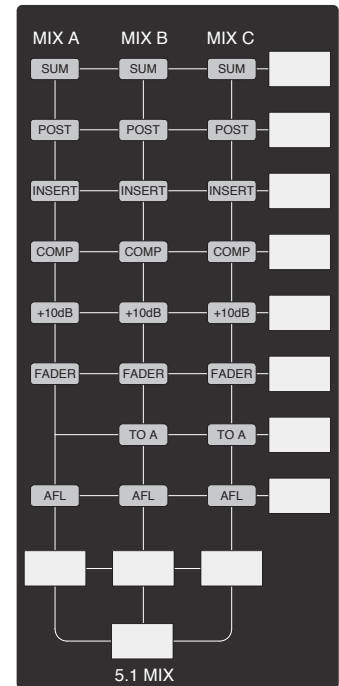

## Main Bus Compressor

Using the same classic design as found on the original SL 4000 Series console, the main bus compressor can be used as a single stereo unit or as a master 5.1 compressor. The compressor is assigned either to one of the Mix A, B, C busses or the 5.1 mix bus via the main bus select matrix (see previous page).

The 'soft' knee point of the compressor, ie. the level at which compression start to take place, is set by the **THRESHOLD** control ( $\pm 20$ dB). This is intentionally designed to change depending on the setting of the **RATIO** control; decreasing the **RATIO** setting lowers the effective threshold, hence maintaining the perceived 'loudness' of the compressed signal. The **RATIO** switch has six settings, 1.5:1, 2:1, 3:1, 4:1, 5:1 and 10:1. **ATTACK** time is switchable in six steps between 0.1 and 30 ms, and the **RELEASE** time is selectable between 0.1 and 1.2 seconds in five steps. The **AUTO** release selection adjusts the release time according to the signal envelope.

The gain **MAKE-UP** simply acts as a level control to compensate for the lowered level that is a consequence of compressing the signal. This control may be set so as not to change the overall output level when the compressor is switched in. The meter indicates dBs of gain reduction.

In 5.1 mode, two buttons, **SRND TO S/C** and **LFE TO S/C** determine whether the surround and LFE channels contribute to the side chain, or not. A further button, **S/C  $\Sigma$** , defeats the normal 'loudest-bus-in-the-mix' side chain operation and substitutes a summing mode so that the gain reduction is proportional to the soundfield energy as opposed to the loudest individual signal.

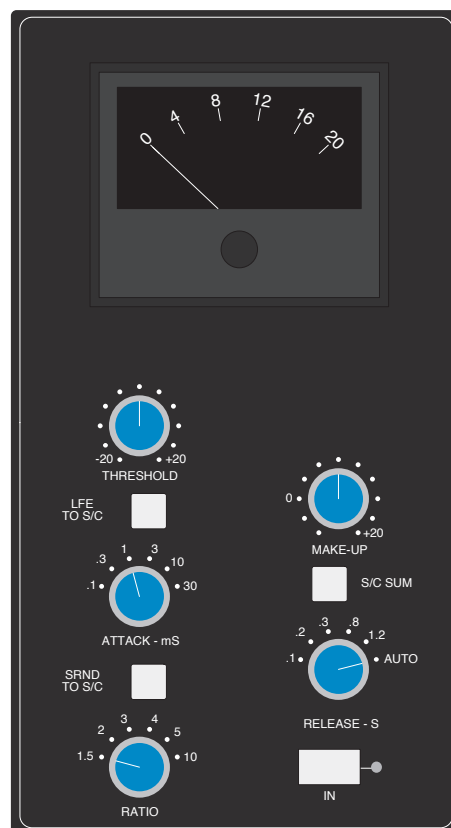

## Master Fader

The master fader can be selected to control the stereo Mix A, B, C busses or the 5.1 mix bus via the main bus select matrix (see previous page). The fader can control the level of all three stereo busses simultaneously but can only set the level for one bus at a time. Level control is via 36-bit, high resolution MDACs.

Alternatively, when **CHAN TO MF** is selected (at the bottom of the Central Routing Panel), the master fader is used to control the selected channel's fader. (See *Master Channel Fader and Mute* in the previous section of this chapter for more details).

The fader is provided with two scales. The one on the left is the normal scale; the one on the right is for use with the **+10DB** function selected via the main bus select matrix (see previous page).

The automation status button and LEDs fitted on this fader are used with the optional automation system.

Following the injection of talkback and tone (see later), the main output busses feed D-connectors on the centre section connector panel.

All the main mix busses are provided with LCD metering above the centre section. In addition, the stereo Mix A bus can be metered on the centre section VU meters.

## Track Bus Master Controls

The output levels of the console's 24 mono Track busses are set by a group of rotary controls in the upper right of the centre section (see left). They all have 10dB of gain when turned fully clockwise; an indent at the '12 o'clock' position corresponds to 0dB gain. Following level control, the bus outputs can be injected with tone (oscillator **TRACK** button) and talkback (talkback **SLATE** button) before being fed to a D-connector on the centre section connector panel.

An **AFL** function (post tone and talkback inject) is provided for each bus. The AFL signal is intelligently assigned to left and right AFL busses. Selecting AFL on a single Track bus output will route signal to both left and right AFL busses. Selecting AFL on odd and even numbered Track bus outputs will route the odd numbered output to the left AFL bus and the even numbered output to the right AFL bus.

A set of LCD bargraph meters in the centre section are dedicated to metering the bus outputs.

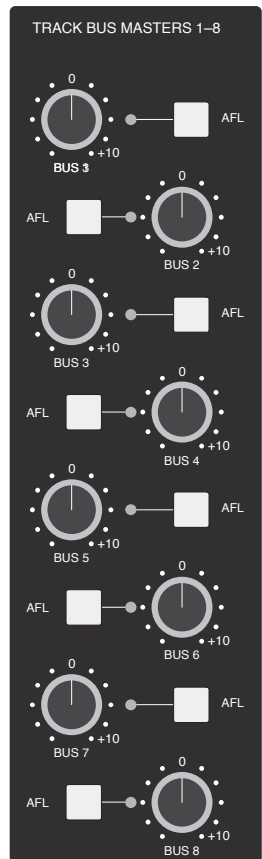
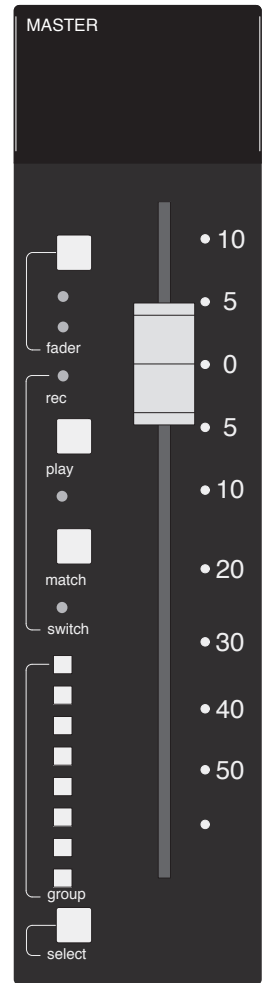

## Monitoring

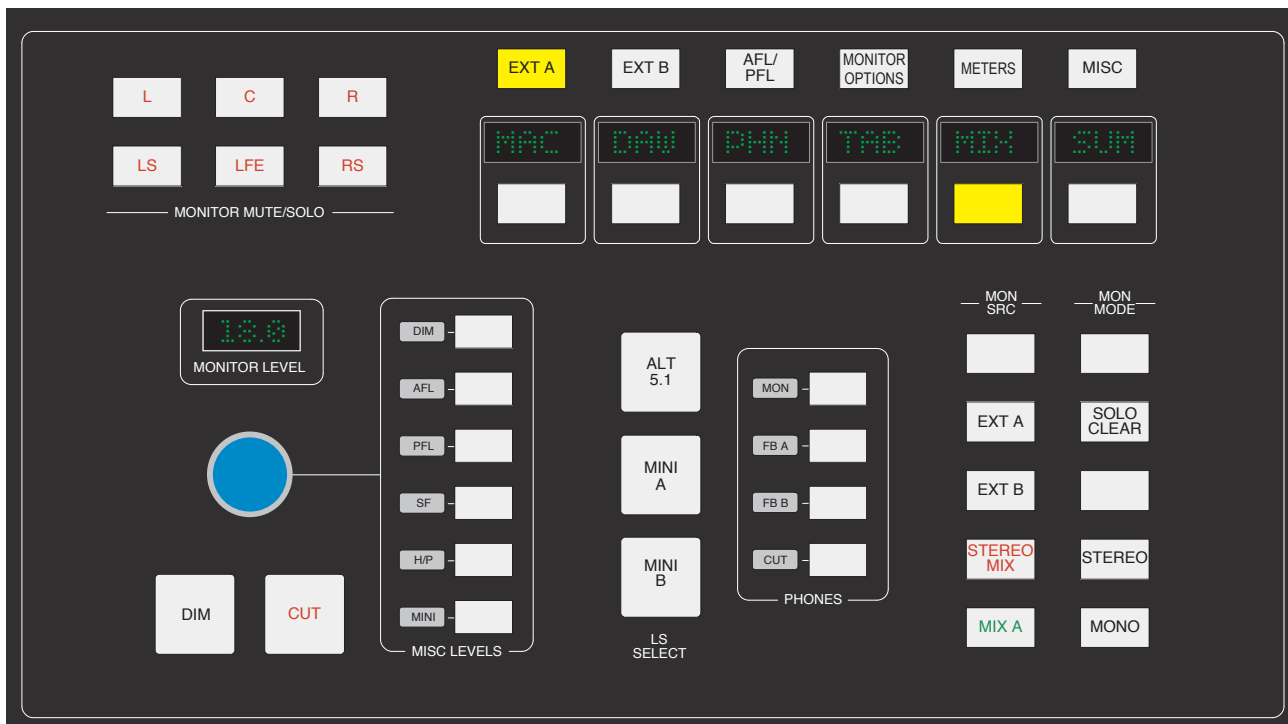

The large knob below the 'MONITOR LEVEL' display normally sets the level of the main control room monitors, according to the monitoring standard selected in the **SSL / MISC / SETUP** menu – see **MONITOR LEVEL DISPLAY AND CALIBRATED LISTENING LEVEL**. The column of six buttons to the right enables this control to be used for the named alternative functions. You will be monitoring on whichever set of speakers is selected from the 'LS SELECT' group: the Main 5.1 speakers ('Main A' is the default with no buttons selected), **ALT 5.1** ('Main B'), **MINI A** or **MINI B**.

The loudspeakers are fed from whatever source has been selected in the 'MON SRC' group of buttons. The alternatives include the **MIX A** bus, the stereo downmix (**STEREO MIX**), and two external source selectors, **EXT A** and **EXT B**. Sources will be intercanceling unless the **SUM** button is selected. All sources to the monitoring are stereo except those brought in via the **EXT A** monitor source selector (see below).

The **STEREO** button folds down the 5.1 inputs to the monitor path via a 5-2 gain-compensated matrix (which also provides the **MON** feed to the foldback outputs), and feeds the result to left and right monitor outputs. **MONO** can be selected with or without **STEREO** and sums the left and right monitor busses, feeding the result equally to the left and right monitor outputs. The **Ø** button precedes the **MONO** button and reverses the phase of the left monitor feed, providing a quick way of checking for any phase anomalies in a stereo mix. If **MONO** is active, selecting the **Ø** button allows the difference (L – R or the 'S' signal) to be monitored instead of the L + R sum.

The **SOLO** button turns the monitor cut buttons (see below) into monitor solo buttons. The **SOLO CLEAR** button lights when any channel **SOLO**, **S/CH LSTN**, **AFL**, or centre section **AFL** or **MONITOR SOLO** button is pressed. Press **SOLO CLEAR** to cancel any Solo/AFL/PFL function.

If either **MINI A** or **MINI B** 'LS SELECT' buttons are selected, the left and right monitor busses are fed to the corresponding stereo mini loudspeaker output. Mini level relative to the main monitors can be trimmed via the main monitor pot by selecting **MINI** in the group of buttons to the right of the monitor pot. When a Mini speaker output is selected, the 5-2 **STEREO** mix is automatically switched into the monitor circuit to deal with any 5.1 sources present.

The **DIM** button dims both main and mini loudspeaker outputs by a preset level. Set this level by selecting the **DIM** button to the right of the monitor pot and turning the main monitor pot. The Dim circuit is automatically activated when any of the following buttons are pressed: **LISTEN, TB ALL, F/B A, F/B B, EXT T/B**, Oscillator to **TRACK** or **MIX**. The **CUT** button cuts the monitor feeds to whichever set of monitors is selected. **CUT** is activated automatically by the **SLATE** talkback function. **CUT** and **DIM** can also be activated externally via the GPIO/Talkback connector. The six main monitor outputs can be muted individually with the **L, C, R, LS, RS** and **LFE** (sub) '**MONITOR MUTE/SOLO**' buttons. These become monitor solo buttons by selecting the **SOLO** button in the 'MON MODE' group (see above).

All the monitor outputs are available for connection to amplifiers via the centre section connector panel. The two 5.1 outputs (Main and Alt) and the two Mini outputs feed two 25-way D-type connectors — 'MON A' and 'MON B'; the two Mini outputs (Mini A and Mini B) also feed individual XLRs for left and right.

### External Source Selectors

Two external monitor source selectors are provided. **EXT A** has four 5.1 inputs. These may be fed by any source of six channels or less. The **MIX** selection provides an important fifth input to **EXT A**, which is used to monitor the 5.1 Main Mix bus when mixing in 5.1 mode.

**EXT B** is a 2-channel selector that may receive up to four stereo sources. In either case, sources may be summed together; this is particularly useful for generating complex foldback mixes or when stem mixing, as it allows the recorded stems to be monitored together with the current mix.

To select an external monitor source, first press either the **EXT A** or **EXT B** button, choose a source from those shown in the display, and then press the soft key under that source (or first press the key under **SUM** to sum selected sources). Finally, route the external source(s) to the monitors by pressing **EXT A** or **EXT B** in the 'MON SRC' group of buttons. The **LTR** selection on **EXT B** provides monitoring for a surround encoder's LtRt output (see next page).

Inputs to the external source selectors are connected via D-connectors (four for External A, one for External B) on the connector panel.

## Monitor Insert

The External A selector output (ie. all 5.1 sources) is automatically routed via a 5.1 insert point to which an encoder/decoder system may be interfaced; this insert may be switched in/out of circuit using the Monitor Options INS function (see next page). The insert send and return appear on two 25-way D-type connectors on the centre section connector panel. The insert point also has connections for the two channel output from the encoder, and the two channel input to the decoder. These allow monitoring of the encoder output ('LtRt') signals and provide automatic routing of the External B selector outputs to the decoder inputs to enable encoded recordings to be played back through the decoder. The logic for this is as follows:

- With no sources selected on External B, the encoder outputs are linked to the decoder inputs.
- Selecting any source on External B will route the External B outputs to the decoder inputs.
- Selecting **EXT A** and **INS** will monitor the insert return; if no source is selected on External B you will hear the External A signals through the encoder and decoder. If a source is selected then you will hear the decoded output of External B.
- Selecting **EXT B** and **INS** and selecting a source on External B will monitor External B.
- Selecting **EXT B** and **INS** with no source selected on External B will monitor the LtRt encoder outputs. The **LTR** soft button lights to show this. Note that **LTR** is selected by turning off all other External B sources.

## Monitor Metering

A dedicated set of six LCD bargraphs above the centre section provide a constant indication of 'FOLLOW MONITOR' levels (ie. what you are currently listening to), plus a stereo meter for the SOLO/AFL bus and mono PFL levels. See later for more on meter options. The 'FOLLOW MONITOR' meter feeds are available via a 25-way D-type connector on the centre section connector panel, for use with external metering.

## Monitor Options

A wide range of monitor options are available via the soft keys and associated display on the monitor panel. Pressing the **MONITOR OPTIONS** button above the display produces the following choices; press the button below an entry to select that option.

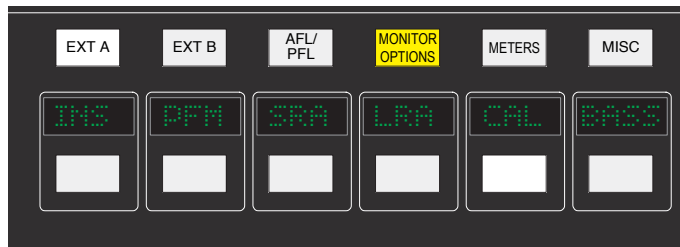

**INS** — Switches the 5.1 encoder/decoder insert into the EXT A monitor path as described on the previous page.

**PFM** — Routes the PFL signal to the Mini A or B loudspeakers. In this mode, PFL level is controlled by the PFL level control only — the Main and Mini monitor level controls have no effect.

**SRA** — Both sets of Main speaker outputs are capable of handling six channels. If you are mixing in 5.1 and the client turns up with an alternative set of ‘front’ (LCR) speakers only, the surround feeds may be locked to the Main 5.1 (Main A) outputs by selecting the **SRA** (‘Surround on A’) function. This allows you to switch to the alternative LCR speakers, connected to the **ALT 5.1** (Main B) output, and still maintain full surround monitoring. A further option (**A2B** — see next page) enables the subwoofer output to be included in this arrangement.

**LRA** — Similar to the **SRA** function except that the LCR monitor feeds are locked to the Main A outputs but an alternative set of surround speakers may be selected by switching to the Main B output. This can be useful in rooms that work on both music, using full bandwidth separate surround speakers, and film using multiple lower powered surround speakers.

## Bass Management

**BASS** — Selecting this option produces a further layer of bass management options (see following pages for options held under **CAL**):

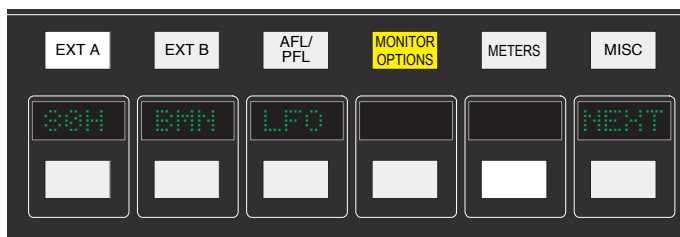

**80H** — Inserts a 7th order, 80Hz, low pass filter into the LFE monitor bus, to deal with listening to 5.1 material that has a full range, unfiltered, LFE channel.

**BMN** — Turns on the Bass Management system. This is designed to extend the low frequency response of the monitoring system, and to simulate the 5.1 monitoring systems in TV and domestic environments. It inserts 12dB per octave, 80Hz high pass filters in the L, C, R, LS, RS monitor outputs, and feeds a pre high pass filter mono sum of these five outputs to an 80Hz, 24dB per octave, low pass filter, which is summed with the LFE monitor bus. Post this summing point, the combined signals feed via a 10Hz subsonic high pass filter before reaching the subwoofer monitor output. These are the default filter slopes. Internal circuit-board links (see Installation Guide for details) allow the links to be set to 12dB or 24dB per octave, and to select whether or not the surround channels are included.

*Note that this option is stored separately for each set of speaker outputs (like the loudspeaker level calibration), so it is possible to have Bass Management enabled on one set of speakers and not on others.*

**LFO** — Normally, the LFE bus level is increased by 10dB post the main monitor level control, as this is a requirement for DVD playback. If you are mixing for SACD, or any other format that requires unity gain on the LFE channel, select **LFO** to restore the LFE bus level to unity gain.

**NEXT** — Produces a second layer of options:

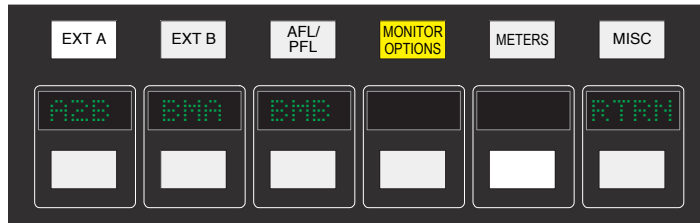

**A2B** — Retains use of the main 5.1 subwoofer, even when you switch to the **ALT 5.1** loudspeaker selection.

**BMA** — Uses the Alt 5.1 subwoofer instead of the main subwoofer for bass management when **MINI A** is selected and **BMN** is on.

**BMB** — Uses the Alt 5.1 subwoofer instead of the main subwoofer for bass management when **MINI B** is selected and **BMN** is on.

**RTRN** — Returns you to the top layer of the **MONITOR OPTIONS** selection.

## Monitor Speaker Calibration

The monitor calibration system enables the level of any loudspeaker connected to Duality Fuse to be trimmed by  $\pm 10$ db. Note that, with the monitor gain at maximum, a trim level of +10dB corresponds to unity gain through the monitor section.

*Do not attempt to carry out loudspeaker calibration unless you have access to accurately calibrated test equipment.*

---

Selecting **CAL** in the first layer of **MONITOR OPTIONS** produces the following options:

Turn on the console oscillator (**OSC ON**) and select the **PINK ON** button; the default level for the console's pink noise output is +4dBu RMS. Adjust using the **PINK** trim pot in the oscillator section if necessary.

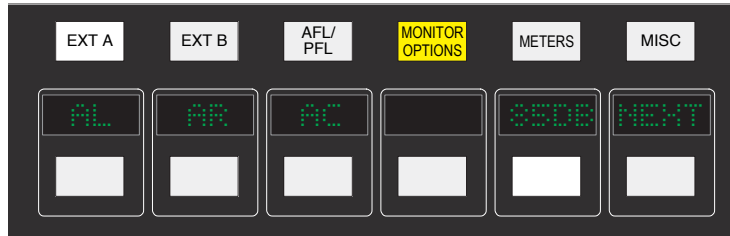

Set the monitor level control to the position you wish to correspond to the calibrated level. A level setting of 8.5 will provide 10dB of additional gain in hand.

Now select the required monitor system — Main 5.1, **ALT 5.1**, **MINI A** or **MINI B**.

Select the **CAL** menu. Pressing either **AL** or **AR** or **AC** will send pink noise to the Left or Right or Centre loudspeakers respectively. Adjust the level for the required SPL (eg. 85dBa C weighting, slow response, on a suitably calibrated dB meter), by turning the main monitor pot left or right from its initial position.

Now work through the rest of the speakers (see below), checking before you calibrate the LFE output whether the **LFO** option (see previous page) is off or on.

*See **MONITOR LEVEL DISPLAY AND CALIBRATED LISTENING LEVEL** for information regarding the **85DB** button.*

---

**NEXT** — selecting this in the first layer produces a second layer of calibration options:

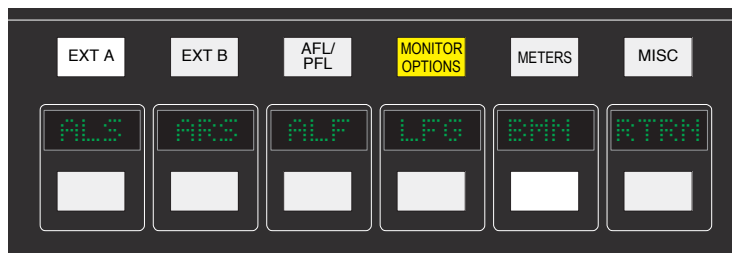

Selecting **ALS** or **ARS** or **ALF** allows you to trim the Left Surround, Right Surround or LFE channels respectively by  $\pm 10$ db, using the method described above.

**LFG** — This stands for Low Frequency Gain and allows the gain of the contribution from the full bandwidth channels to the subwoofer output to be adjusted. Like all the speaker calibration settings it must be set for each set of speaker outputs (assuming Bass Management is in use).

Having lined up the six main speakers, select **LFG**. In **LFG** mode all speakers are initially muted, and the six monitor cut buttons will light; uncut the left output, and with the bass management turned on (note that the **BMN** selection in the **BASS** menu is duplicated in the **CAL** menu), adjust the **LFG** gain for a flat low end response. Cut the left output, uncut the right output, and check this has a flat low end response. Repeat for all channels. Depending on how well matched the monitors are, you may have to adjust the **LFG** gain slightly.

Note that when **LFG** is on, the LFE monitor output is always cut. This does not mute the actual subwoofer output, only the LFE signals feeding it. This ensures that you are only measuring the contribution from the Bass Management system.

## Monitor Level Display and Calibrated listening level

The **SSL / MISC / SETUP** menu provides two additional options:

**MONITOR GAIN DISPLAY:** Music (Off to 11)  
Film (Off to 95dB)  
Gain (Off to 0dB)

**MONITOR SET CAL LEVEL IS:** 70 - 90

Furthermore it is possible to change the Monitor Level pots resolution between 'Fine' and 'Large' in '**MUSIC**' or '**GAIN**' modes by pushing down on the pot. The display above it will show which mode it is in. 'Fine' mode makes adjustments in 0.1dB steps while 'Large' mode adjusts the value in 0.5dB steps.

When working in '**FILM**' mode pushing down on the Level pot will adjust the monitor volume to the user defined calibrated level selected in the **SSL / MISC / SETUP** menu. Normal selection here would be the international recognized 85dB but it is possible to set a range from 70dB to 90dB. It is recommended that you use a SPL meter to calibrate your studios monitoring level to match that displayed on your Monitor Level display.

---

*Note that the monitor gain corresponding to +85dB SPL can be set in the **MONITOR OPTIONS / CAL** page 1 by adjusting the main monitor level control to give an SPL of 85dB, then pressing the **85DB** switch.*

---

Note that if you make a change to this value in the Setup menu while running in Calibrated mode this change will not be reflected until you come out of Calibrated mode and re-enter it. You can tell which mode you have switched into as it will display either '**CAL**' for calibrated or '**UCAL**' for uncalibrated. Bear in mind that switching to a calibrated level of 85dB may cause a significant increase in listening volume so take care not to damage your hearing and of course your loudspeaker monitoring system.

The third option setting '**GAIN**' allows a range of volume level settings where the maximum value is 0dB. All other values are reductions of this level through to '**OFF**'.

## SOLO / AFL / PFL

The console's default solo mode is a destructive solo-in-place — soloing a channel cuts all other channels. The alternative solo modes — AFL, PFL and Solo-in-front are selected via the soft key display on the monitor control panel. Press the **AFL/PFL** button above the display to produce the following options:

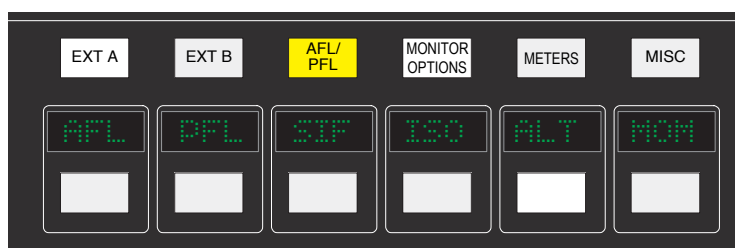

- AFL** Pressing a channel **SOLO** button routes the post channel pan signal, via the stereo AFL bus and the AFL level control, to the currently selected monitor speakers.
- PFL** Pressing a channel **SOLO** button routes a mono pre-fade signal, via the PFL bus and the PFL level control, to the left and right Main monitor speakers. Optionally, PFL signals may be fed to the Mini loudspeakers — see **PFM** in **MONITOR OPTIONS**.
- SIF** (Solo-In-Front) Pressing a channel **SOLO** button routes a mix of the AFL signal and the selected left and right monitor sources to the monitor outputs. The SIF level control (select the **SIF** button to the right of the main monitor pot and use the pot to set the level) adjusts the balance between AFL signal and desk output.
- ISO** To solo isolate a number of channels, select **ISO**, press the **SOLO** buttons on all channels to be isolated, then deselect **ISO**. The SOLO switches on isolated channels will flash.

---

*Solo-isolated channels can be set to automatically solo in AFL mode via the **ISOLATED CHANNELS AFL ON SOLO**: option in the **SSL / MISC / SETUP** menu.*

---

- ALT** Makes channel **SOLO** buttons intercancel with each other, so that soloing one channel will clear any other solo selections.
- MOM** This option makes all the channel **SOLO** buttons momentary.

---

*Note that **ALT** and **MOM** do not affect the operation of centre section AFL and SOLO functions*

---

Solo, AFL and PFL signals are all metered on the centre section **SOLO** meter. See **CENTRE SECTION METERING** for more information.

When auditioning signals which are low in the mix, it is possible to boost the solo bus signal level by up to 10dB via the **SOLO GAIN BOOST**: option in the **SSL / MISC / SETUP** menu.

---

*Note that this boost is applied at the final output stage of the signal and is not reflected in the Solo meters. If insufficient headroom is available, less gain will be applied.*

---

### Cue/FX Send Master Controls

Each channel is fitted with two Cue Stereo and four mono FX sends for use as foldback, feeds to effects devices, etc. The Cue Stereo outputs from each channel may be routed to one of two busses — Stereo Cue A or Stereo Cue B. FX 1-4 feed their respective busses.

The master output level controls for these busses (in the top right of the centre section — see left) all have 10dB of gain when turned fully clockwise, and an indent at the '12 o'clock' position, which corresponds to 0dB gain.

An **AFL** button is provided for each output. The AFL signal is intelligently assigned to left and right AFL busses. Selecting AFL on a single FX output will route signal to both left and right AFL busses. Selecting AFL on odd and even numbered FX outputs will route the odd numbered output to the left AFL bus and the even numbered output to the right AFL bus.

The two Cue Stereo and four mono FX outputs are available to external devices via a D-connector on the centre section connector panel. The Cue outputs are also available as sources to the Foldback outputs (see below).

A dedicated set of LCD bargraphs just above the master controls provides metering of the Stereo Cue A, Stereo Cue B and FX busses (see **CENTRE SECTION METERING**).

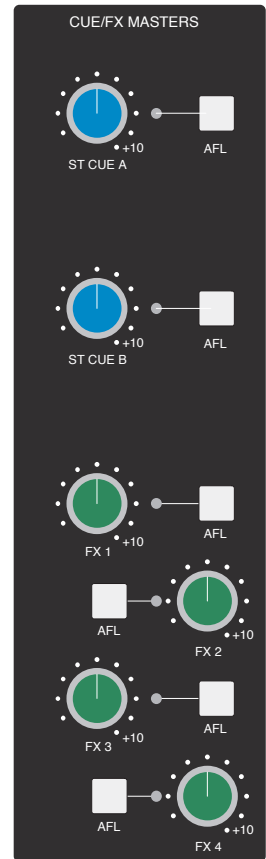

### Foldback and Headphone Outputs

The console provides three stereo outputs — Foldback A and B, intended for use in the studio for headphones or LS playback, plus a stereo headphone feed for control room use; a socket for this is provided beneath the buffer rail in the centre section. The foldback outputs feed 1/4" jacks on the centre section connector panel, from where they may be connected to amplifier inputs.

The master controls for Foldback A and B are provided by two identical sections fitted just below the main output compressor (see left — only Foldback B shown).

Each output has a dedicated **LEVEL** control, **CUT**, **AFL**, and six source selector buttons with associated level controls:

The **MIX 1** pot controls the contribution of Main stereo mix bus A (**MIX A**) and/or the output of Cue Stereo A (**CUE A**), to the foldback mix.

The **MIX 2** pot controls the contribution of the stereo downmix signal (**ST MIX**) and/or the output of Cue Stereo B (**CUE B**), to the foldback mix.

In addition, the stereo Main monitor output (**ST MON**) and the output of External Source Selector B (**EXT B**) may be selected as sources.

Dedicated **F/B A** and **F/B B** talkback buttons are used to add talkback to the foldback outputs.

The **TALK TO FB:** option in the **SSL / MISC / SETUP** menu determines whether the talkback signal replaces or sums with the foldback mix.

HF and LF shelving equalisers are provided on the outputs.

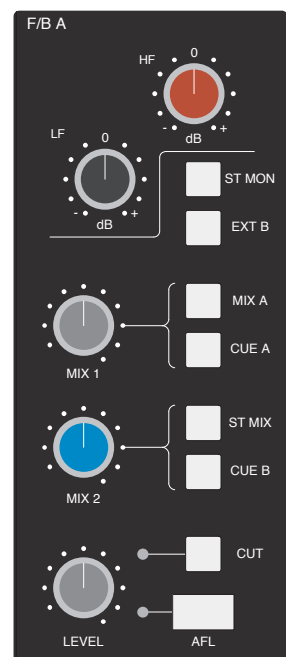

A small area of the monitor control panel (see right) provides source selection (control room monitor and foldbacks) and a **CUT** function for the console's stereo headphone output. Note that the **F/B A** and **F/B B** signals are taken from before the foldback master level and EQ controls.

The level of the headphone output is set using the **H/P** button to the right of the Main monitor pot, in conjunction with the pot itself.

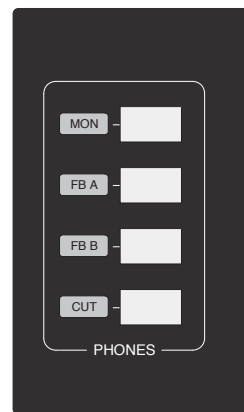

### Stereo Return Channels

The console's four stereo return channels may be driven by the outputs of devices that have been fed from the corresponding mono FX busses. Alternatively, the returns may be used for any additional stereo input required for the mix. Inputs to the returns are interfaced to the console via a D-connector on the centre section connector panel.

Four identical sets of controls are provided; the controls for Stereo Return 1 are shown on the right. Each return can be routed to the console's Main mix busses, with full control of level and panning. Default routing is post the **CUT L** and **CUT R** input cut switches to Mix A, B or C via the master **LEVEL** control.

To route a Stereo Return to the required mix bus, enable the Central Routing Panel by pressing the + and – buttons simultaneously, then press and hold down the **AFL/SEL** button at the bottom of the Stereo Return. The Routing Panel display will change to read **ST 01**, (**02**, **03**) and the **MIX A**, **MIX B** and **MIX C** buttons above can be used to assign the selected Stereo Return to the required bus(es).

The **BALANCE** pot provides a differential Left/Right gain trim for the stereo input signal. This is followed by a variable stereo **WIDTH** control, which can reduce the stereo image to a mono centre phantom point source. The **MONO** button sums the inputs and simultaneously alters the action of the **BALANCE** control to that of a conventional two channel pan pot. This is very useful when you are using a mono FX device, as it saves having to parallel the return inputs.

For 5.1 work, selecting the **FB PAN** button causes the **WIDTH** control to act as a Front/Back pan pot. The **FOCUS** control progressively subtracts the front L R signals and re-routes the sum to the C (Centre) bus (Bus 3).

Selecting the **STEREO** button defeats the surround panning options and provides switched routing via the central routing panel. Press and hold the **AFL/SEL** button on the return to activate the panel, and use the panel's routing buttons to select MIX A, B or C (or combination thereof).

Return signal may also be fed independently, post the **CUT L** and **CUT R** input cut switches, to Foldback outputs A and B by selecting the **FB A** and/or **FB B** buttons and adjusting the **STUDIO** control.

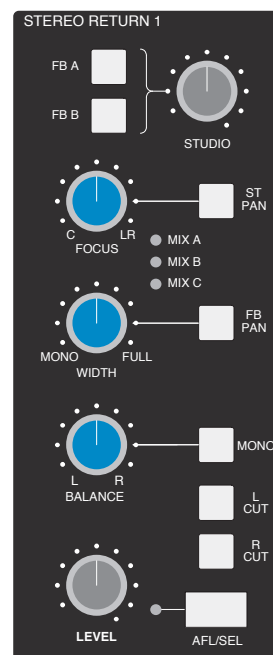

## Misc Options

A number of useful options can be accessed via the MISC menu. Press the **MISC** button above the display to produce the following options:

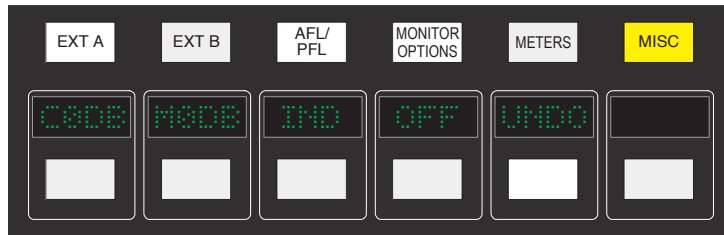

**C0DB** Sets all channel faders to 0dB.

**M0DB** Sets all group master faders to 0dB.

**IND** When selected, pressing any fader's **FADER** button will set that fader to 0dB. The **IND** button flashes to indicate that it is active.

**OFF** Moves all faders to  $-\infty$ .

**UNDO** Reverses the last action.

---

*Note that there is one level of undo. The button lights to indicate that an 'undo' is available.*

---

## Communications

A group of communications buttons (talkback etc.) are fitted below the central routing panel. A built-in talkback microphone and pots to set the level of **TB TO FOLDBACK**, **TALKBACK OUT** (an external talkback feed), **SLATE** level (talkback to Main Mix, Track bus and channel outputs) and an incoming Listen mic, are provided in the 'Comms' section above the DAW control TFT screen (see right).

Note that a gain control for the talkback mic preamp is provided on the connector panel adjacent to the external talkback output jack. If required, an external talkback mic may be connected to the console's talkback distribution circuitry via an XLR on the connector panel. When using this facility, turn the console mic preamp gain fully anticlockwise (off) if you no longer wish the inboard mic to contribute to the talkback system.

Note also that, apart from **SLATE**, which cuts the monitors, all the following functions dim the monitors. All the buttons, apart from **LISTEN** and **RED LIGHT**, can be selected to be latching, momentary or to be inhibited in Play or Record – see opposite for details.

**SLATE** — Interrupts the Main Mix and Track bus outputs with talkback.

**F/B A** and **F/B B** — Adds (or optionally replaces) talkback to the associated foldback outputs after the level and cut controls.

**EXT T/B** — Sends talkback to an external feed, available via a 1/4" jack on the connector panel. Level is adjusted using the **TALKBACK OUT** pot (see above).

**TB ALL** feeds talkback to the foldback sends and the external talkback output.

**LISTEN** — Injects an external mic signal (connected via an XLR on the centre section connector panel) onto the Mini A loudspeaker set and dims the main loudspeakers. This button is latching (optionally inhibited in Play or Record); the level is adjusted using the **LISTEN** pot (see above). The mic is usually placed in the recording area. The circuitry features SSL's legendary listen mic compressor, the sound of which is much loved by many experienced SSL users, so the connector panel provides a post compressor output XLR — 'Listen Mic Out'.

**RED LIGHT** — this provides an isolated contact closure for hooking up to a studio red light via an external relay box.

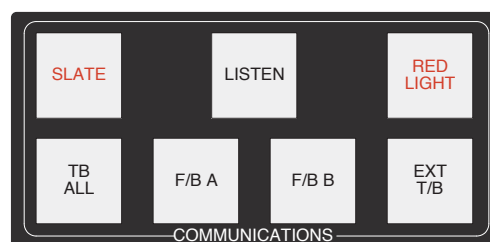
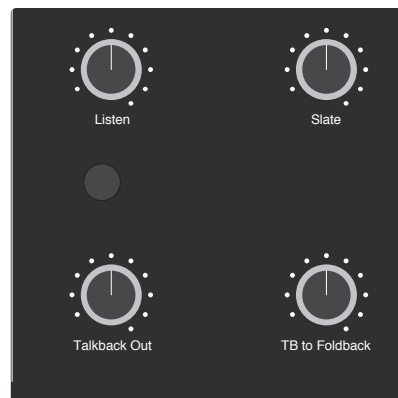

*The talkback button functions are all duplicated on a Talkback/GPIO connector on the rear of the console, as are the monitor **CUT** and **DIM** switches. See the Duality Fuse Installation and Setup Manual for more information.*

The following options for the console's communications are located in the **SSL / MISC / SETUP** menu:

- TALKBACK SWITCHES:** This selects the operation of the talkback buttons: Momentary / Latching / Auto (Play) / Auto (Record).
- LISTEN SWITCH:** This selects the operation of the Listen buttons: Latching / Auto (Play) / Auto (Record).
- RED LIGHT SWITCH:** This selects the operation of the red light switch: Manual / Auto (Play) / Auto (Record).

---

*Note that for the **TALKBACK SWITCHES** and **LISTEN SWITCH** options, 'Auto' inhibits the switch when the transport is in the status indicated. In the case of the red light, 'Auto' forces the red light on when the transport is in play + record.*

---

- TB SWITCHES DISABLE LISTEN:** This allows the Listen function to be switched off when talkback is activated, thus avoiding feedback problems.
- TB TO FB:** (Sums / Replaces) When assigning talkback to foldbacks, this option defines whether talkback sums or replaces the normal foldback signal.

## Oscillator

The word oscillator is a slight misnomer in this case, as the console actually provides a comprehensive tone and pink noise generator!

The 'Oscillator' section (see right), located just above the DAW control TFT screen, contains controls for frequency, level and routing of tone or pink noise to the Main Mix and Track bus outputs and to the monitor outputs for use in monitor calibration.

**OSC ON** — Activates the oscillator output (surprise, surprise!). It's good practice to turn the oscillator off when recording, to prevent any accidental routing to desk outputs.

**PINK ON** — Switches the output from tone to pink noise. Note that the pink noise level can only be adjusted using the **PINK** 'Cal' preset.

The **LEVEL** control adjusts the level of the tone generator from  $-25\text{dBu}$  to  $+20\text{dBu}$ .

When fully anticlockwise, a preset 'Cal' level is selected that can be calibrated using the multiturn preset located below the level control; a red LED lights to show when the level control is in the calibrated position.

When **OSC ON** is selected, the rotary **FREQ** switch provides six preset frequencies.

The oscillator may be routed to the Main **MIX** busses, the **TRACK** busses and the **CHANNEL OUT** (individually or simultaneously).

The oscillator output is also available on an XLR on the centre section connector panel.

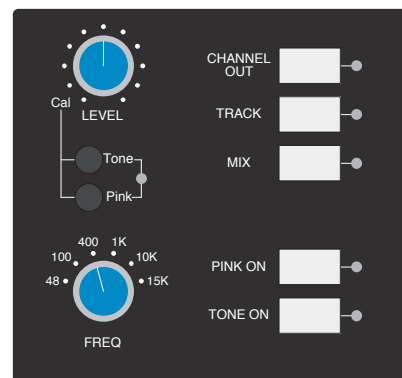

### Mix Reassign Matrix

This useful matrix, to the left of the main output compressor (see right), adds the selected mix(es). post output level control, to the six Main Mix busses. Three stereo mixes — stereo **CUE A** and **CUE B**, plus the output of the **EXT B** stereo monitor selector, can be reassigned to Main Mix busses 1 and 2 (Mix A). The 24 Track busses are split into four groups of 6, and are re-assigned in those groups to all of the Main Mix busses (busses 1 and 2 to Mix A, 3 and 4 to Mix B, 5 and 6 to Mix C, etc.). This provides up to four 5.1 stems or four triple stereo bus sets.

### LFE Channel

This section (see right) enables a low pass filter to be switched (**LFE FILTER**) into the LFE mix bus (Bus B Right) when working in surround. Two filter frequencies are provided — the default 120Hz filter or, when the **80HZ** button is pressed, a 80Hz option. The filter slope is 12dB/Octave.

### Stereo Mix Matrix

This matrix (see right) is used to sum the console's Main Mix busses, with two exclusive modes of operation.

Firstly, the three rotary controls and their associated **ON** buttons act as a 5.1 to Stereo Downmix matrix to control the centre, surround and LFE contributions added to the original 5.1 front L and R channels. By default, the downmix is sourced from the Main Mix bus outputs, post processing and level control. **INP PRE** feeds the matrix directly from the busses' mix amps, thereby bypassing all processing.

The **MIX A, B** and **C** buttons are used to select a second mode of operation, which provides a simple bus sum of the six Main Mix busses, when they are being used as three stereo pairs or stems. The summing is post processing and level control. In both cases, the resultant stereo mix has a master **LEVEL** trim and a separate pre level control insert point (**INS**). The insert return supports the 'Sum' option, as found on the **BUS SELECT MATRIX** for Main Mix bus insert points. This mode is selected in the **SSL / MISC / SETUP** menu, selected via the centre section TFT screen.

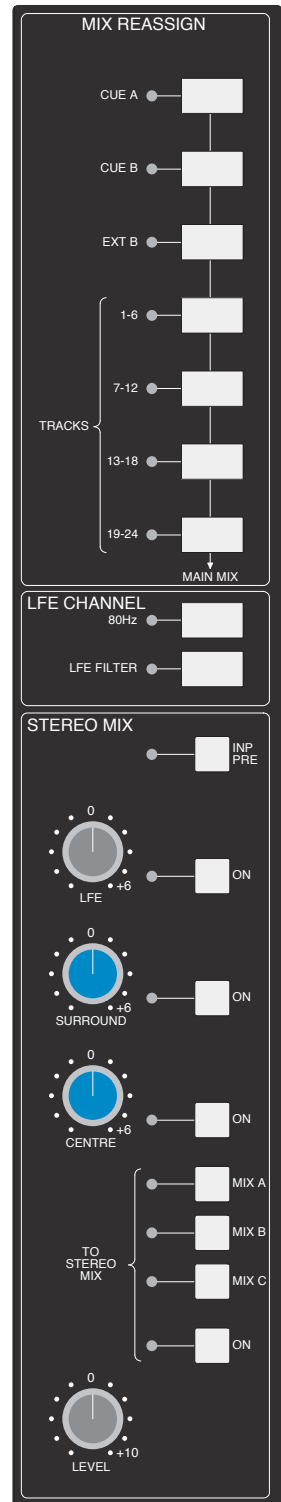

## Group Control Faders

The console centre section features eight control group master faders. Each group master fader may control a number of slave channel faders. Additionally, group master faders may control other group master faders.

Duality Fuse features traditional VCA style grouping – the gain equals the gain of the slave plus the gain of the master (in dB). Assigning a fader to a group immediately changes the gain by the amount the master is displaced from 0dB. Group assignments may be stored as part of a Total Recall (option) setup.

Selecting channel faders to a group is simple — press the **SELECT** buttons of the channels you want to include in the group then, in the centre section, press the **GROUP** button at the foot of the required group fader (see right). The group display on each fader will reflect your choice.

To assign a group master to be controlled by another group master, press the **GROUP** button on the group master to be controlled (ie. the slave), and while keeping this button pressed, press the **GROUP** button on the group master that will control the slave. Use the same procedure to deselect an assigned master from the slave group.

Pressing the **CUT** button on a group master fader will have the same effect as pressing the **CUT** buttons on all the slave faders. The underlying state of these functions on slave faders can be changed while a group master **CUT** is active, but the group master **CUT** state can not be overridden by the local function. Group fader **CUT** buttons may be automated if the optional automation system is active. See Section 5 for more details.

Similarly, when in **SIF**, **AFL** or **PFL** solo modes, pressing the **SOLO** button on a group master fader will have the same effect as pressing the **SOLO** buttons on all the slave faders. However, in default (solo-in-place) solo mode, group solos work slightly differently: pressing the **SOLO** button on a group master fader will result in all channels not in that group being cut. This means that pressing the **SOLO** button on a fader within that group will cause the other faders within the group to be muted, overriding the group **SOLO** button.

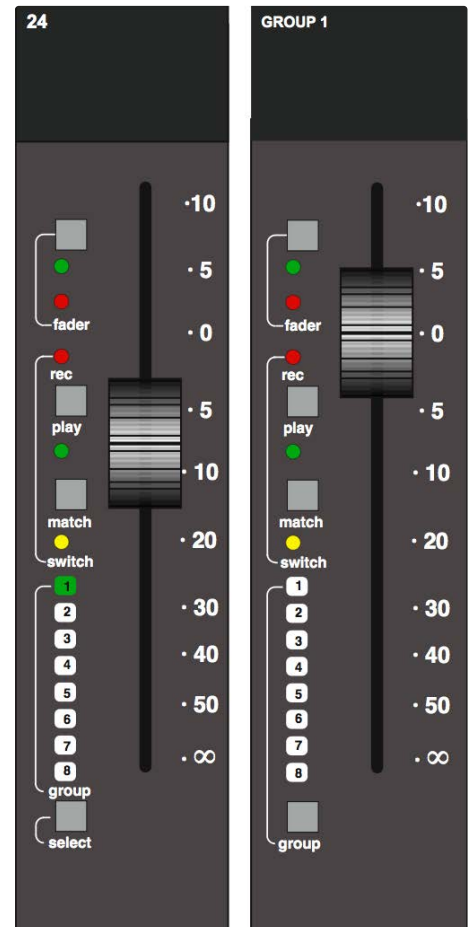

If legacy Automation is enabled via the *SSL / Misc / Setup* menu, an additional grouping option, Servo Grouping, can be selected from the Fader Grouping Mode entry. With Servo grouping active, moving the master fader will cause the slave faders to move, emulating the grouping system found on early moving-fader automation systems where the audio signal passed through the fader.

*If you load a mix created in one grouping mode while the other grouping mode is active, the mix levels for playback will be automatically corrected for the current mode.*

*Servo mode allows you to set a group master level below which slave faders will not have their balance altered. The lockout level range is -35dB to -70dB or OFF.*

*The servo grouping mode allows faders to be added to and removed from groups without changing levels.*

## Centre Section Metering

The panel above the main centre section features LCD and analogue metering for the console's main and auxiliary outputs:

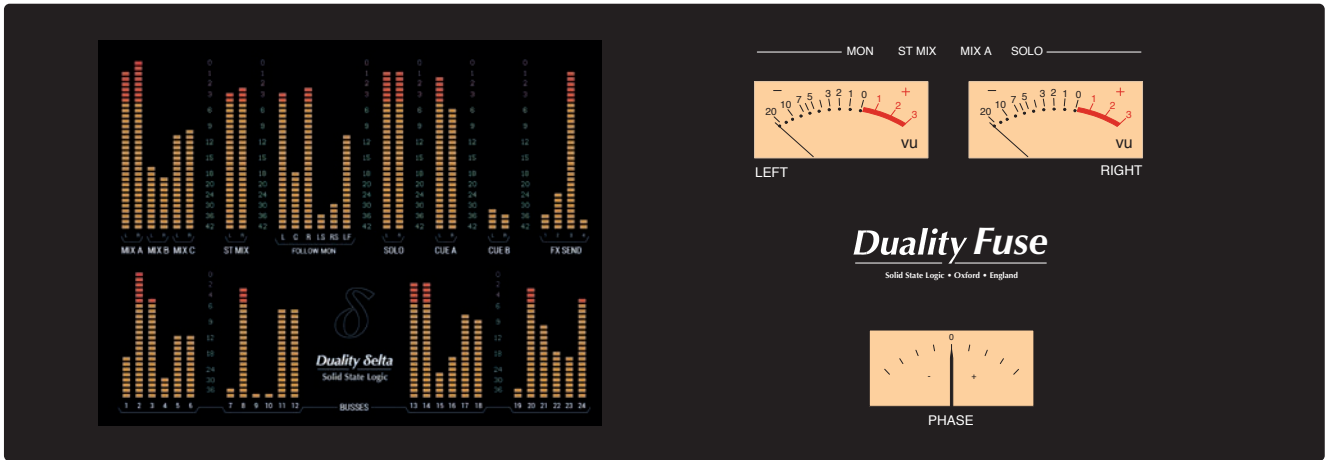

On the left of the centre section meter bridge are six sets of LCD bargraphs. These are dedicated to the metering of (from left to right) the following busses:

- AL, AR, BL, BR, CL, CR **MAIN MIX** (when working in 5.1, these become L, R, C, LF, LS, RS)
- L, R **ST MIX** (downmix)
- L, C, R, LS, RS, LF **FOLLOW MON** (monitor)
- L, R **SOLO**, AFL, PFL bus
- L, R **CUE A** and **CUE B**
- 1-4 **FX SENDs**
- 1-24 Track **BUSSES**

The standard scale is +24dB for 0dB FS (top of the scale). Options for different 0dB FS levels are available via the **SSL / MISC / SETUP** menu (see next page).

To the right of the bargraphs are two VU meters and a phasemeter. These meter the Left and Right outputs of three mix busses, as selected via the **METERS** menu (see next page).

## Meter Options

Meter options are provided by soft key selections on the monitor panel; select the **METERS** button to produce the following selections:

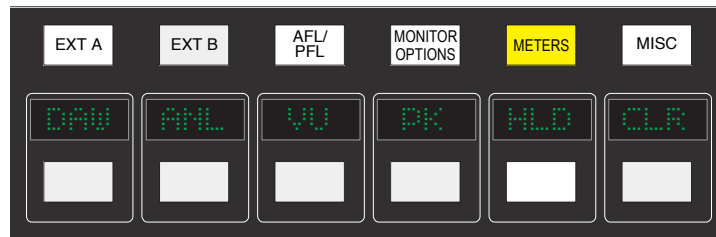

**DAW** Locks the channel meters to the DAW layers.

**ANL** Locks the channel meters to the analogue channels.

**VU** Toggles the feed to the VU meters between the following, as indicated above the VU meters:

**MON:** The current Left and Right monitor outputs

**DMIX:** The stereo downmix output level

**MIX A:** The Main Mix A bus.

---

*Note that any **AFL** or **SOLO** selection will automatically cause the VU meters to meter the console's solo bus.*

---

**PK** Switches the meters to peak reading mode; peak readings are held for 3 seconds.

**HLD** Select this to hold the peak readings indefinitely.

**CLR** Press to clear the currently held peak readings.

## Setup Menu

The centre section TFT screen provides access to a setup menu that holds a number of useful console-related items. Select **SSL** followed by **MISC** and then **SETUP** (see Section 3 if you are not familiar with the use of the TFT and its associated soft keys).

To change a setting, use the left hand V-pot to select the item, then press the V-pot to enter adjustment mode. Turn the V-pot to the desired setting and press it a second time to save the setting to non-volatile memory.

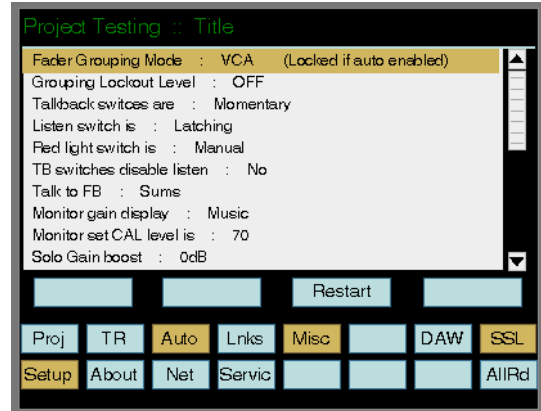

The **SETUP** options are as follows:

### Talkback

- TALKBACK SWITCHES:** Select the operation of the talkback buttons: Momentary / Latching / Auto (Play) / Auto (Record).
- LISTEN SWITCH:** Select the operation of the Listen buttons: Latching / Auto (Play) / Auto (Record).
- RED LIGHT SWITCH:** Select the operation of the Red Light switch: Manual / Auto (Play) / Auto (Record).
- TB SWITCHES DISABLE LISTEN:** This allows the Listen function to be switched off when talkback is activated, thus avoiding feedback problems.
- TB TO FB:** (Sums / Replaces) When assigning talkback to foldbacks, this option defines whether talkback sums with or replaces the normal foldback signal.

---

*See **COMMUNICATIONS** for more details of these options*

---

### Monitor section

- MONITOR GAIN DISPLAY:** The calibration of the main monitor Gain pot and display can be set to one of three industry-standard monitoring modes: Music (Off to 11) / Film (Off to 95dB) / Gain (Off to 0dB)
- MONITOR SET CAL LEVEL:** When in Film monitoring mode, the calibrated listening level can be adjusted: 70 – 90 (dB).

---

*See **MONITOR LEVEL DISPLAY AND CALIBRATED LISTENING LEVEL** for more details of these options*

---

- SOLO GAIN BOOST:** When auditioning signals which are low in the mix, it is possible to boost the solo bus signal level. (Range: 0 – 10dB).
- ISOLATED CHANNELS AFL ON SOLO:** Set solo-isolated channels to automatically solo in AFL (ON/OFF).

## Desk Setup

<b>STEREO MIX INSERT MODE</b>	This enables the stereo mix matrix 'SUM' option to be selected, where the insert return sums with the main signal path. Select REPLACE to disable this function.
<b>INPUT CUT ENABLE</b>	If set ON, the channel strip <b>CUT</b> button will cut prefade sends, ie. Aux and CHOP sends (ON / OFF).
<b>ANALOGUE METER SCALING</b>	Set the analogue level corresponding to 0dB FS on the console meters. (Range 18, 20, 22, 24 dBu).

## DAW setup

The next few items in the **SETUP** menu are concerned with DAW interconnection, but are included here for completeness; see Section 3 for more details. Note that changes to any of these DAW settings will require a console reboot before they take effect: hold down the **RESTART** softkey and press the **CONFIRM** softkey which appears to its right.

<b>TRANSPORT LOCK LAYER*:</b>	Select the master DAW layer for transport control between DAW 1, DAW 2 or Off.
<b>DAW 1 JOG WHEEL SENDS:</b>	Define the control data sent by the jog wheel for HUI DAWs. Normally the Jog Wheel has no action unless Scrub or Shuttle are enabled. The Nudge option allows the Jog Wheel to scroll through the session Timeline using the nudge (+/-) commands. Options are Jog / Nudge (40 / 20 / 13 / 10 / 8 / 6 / 5 per revolution). The Scroll action depends on the nudge value set in Pro Tools and the number of commands sent per a jog wheel revolution; adjust to taste. When DAW 2 is HUI, there is a <b>DAW 2 JOG WHEEL SENDS*:</b> menu entry.
<b>MIDI CONNECTS VIA:</b>	Select the ports used for MIDI connections: MIDI Ports (the physical MIDI ports on the console) or Network (MIDI over Ethernet).
<b>DAW 1:</b>	Select from Protools HUI / Logic / Logic Handshake / Nuendo / Digital Performer / Sonar
<b>DAW 2*:</b>	Select from Protools HUI / Logic / Logic Handshake / Nuendo / Digital Performer / Sonar / None
<b>FIRST PHYSICAL CHANNEL DAW 1:</b>	Select the console channel number that is controlling the first track number on DAW 1. When DAW 2 is assigned, there is a <b>FIRST PHYSICAL CHANNEL DAW 2*:</b> menu entry.
<b>CHANNEL COUNT DAW 1:</b>	Select the total number of channels dedicated to DAW control (8 – 48 in steps of 8). When DAW 2 is assigned, there is a <b>CHANNEL COUNT DAW 2*:</b> menu entry.
<b>SINGLE LAYER*:</b>	Assign both DAWs to a single layer (ON/OFF).

---

*\* Not displayed if **MIDI CONNECTS VIA: MIDI PORTS** is selected.*

---

## Desk settings

<b>SCRIBBLE STRIP BRIGHTNESS</b>	Use this to adjust the channel scribble strip brightness (range: 1-6)
<b>TFT BACKLIGHT BRIGHTNESS</b>	Use this to adjust the backlight level (range: 1 – 8)
<b>TURN OFF DISPLAY AFTER</b>	Shuts off the TFT display after a predetermined time: 30 mins to 5 hours in 30 minute increments.
<b>CONSOLE CHANNEL COUNT</b>	Should be set to the size of your console: 24, 48, 72 or 96. This setting determines the range of channels selected by the Central Routing Panel's <b>ALL</b> button.

---

*The TFT and scribble strip displays can each be turned off by turning the control pot clockwise (beyond 8 or 6) to 'Off'.*

---

NOTE. The following Automation options are only available if the console is rebooted into Legacy Automation mode.

## Grouping

<b>FADER GROUPING MODE:</b>	Selects the fader grouping mode (Servo / VCA). (See <b>GROUP CONTROL FADERS</b> for more details).
<b>GROUP LOCKOUT LEVEL:</b>	Set the group master level below which slave faders cannot have their balance altered (available in Servo grouping mode only). The lockout level range is –35dB to –70dB or OFF.

## Automation

<b>GLIDE FRAMES:</b>	Sets the ramp time in frames for the automation SNAP mode. (range 0 – 255)
<b>ROLLBACK THRESHOLD FRAMES:</b>	Sets the number of consecutive frames that the system needs to see to determine if a Rollback has taken place. The range is 0 – 10; the default is 0 frames. Increase as required if a Rollback occurs when you stop the timecode master.  Setting the threshold to 0 means that mix data can be entered in non real time by setting the DAW nudge value to a frame, and using the nudge forward command to step through the mix whilst moving a fader or operating switch functions. A reverse nudge command will automatically force a rollback, returning the mix pass status to Mix Review and incrementing the rollback counter.
<b>IN MIX SHOW:</b>	When using the automation, you have a choice of what is displayed on the consoles channel scribble strips (and below the Group and Master fader levels in the Centre Section TFT screen). The choices are:  Automation Mode: displays the status of the faders – Auto, Safe or Manual; Channel names in Mix running: displays the channel names once <b>EXECUTE</b> is pressed in automation, Channel names: displays the channels names regardless.
<b>MIX UPDATE MODE:</b>	Sets the default automation mode at the start of an update mix (Replay / Absolute / Trim).
<b>AUTOMATED SWITCHES TURN OFF ON:</b>	Select whether the off function of automatable switches is sent on the down-press or release of the button (Press / Release).

---

*This page is almost blank*

---



# *Duality Fuse*

**Operator's Manual**

**SECTION 3**

**DAW Control**

*This page is intentionally almost blank.*

# Section Contents

<b>Section Contents</b> .....	<b>3-i</b>
<b>Introduction</b> .....	<b>3-1</b>
DAW Controller Features Summary .....	3-1
Console Focus .....	3-2
DAW Layers .....	3-3
<b>Connecting Duality Fuse to DAWs</b> .....	<b>3-4</b>
<b>DAW Control Operations</b> .....	<b>3-5</b>
V-pots .....	3-5
<b>The Master Control Panel (HUI Mode)</b> .....	<b>3-7</b>
Channel Banking Controls .....	3-7
DAW Window Buttons .....	3-7
DAW Utility Buttons .....	3-8
Modifier Buttons .....	3-8
The Default Button .....	3-9
<b>Channel Functions</b> .....	<b>3-11</b>
DAW Meters .....	3-11
Channel Fader .....	3-11
Channel Solo and Cut Panels .....	3-12
Edit Mode .....	3-13
Select Mode .....	3-14
Working with the Channel V-pots .....	3-14
<b>Input, Output and Send Routing</b> .....	<b>3-17</b>
Viewing Input, Output and Send Routing .....	3-17
Setting input, Output and Send Routing .....	3-17
<b>Motion Control</b> .....	<b>3-19</b>
Basic Transport Controls .....	3-19
Additional Transport Controls .....	3-19
Other useful transport modes .....	3-20
Setting Pre and Post Roll .....	3-20
Setting start (In) and end (Out) Times .....	3-20
Audition .....	3-20
Footswitch Control .....	3-21
Zoom, Navigation and Selection Modes .....	3-21
Scrolling Within a Window .....	3-22
Shuttle/Scrub Wheel .....	3-22
Numeric Keypad .....	3-23
<b>Plug-In Editor</b> .....	<b>3-25</b>
Plug-In Editor Display .....	3-25
Plug-In Editor Controls .....	3-25
Paging Buttons .....	3-25

---

Selecting a DAW Channel for Plug-In Control . . . . .	3-26
Timecode/Bars & Beats/Samples Display . . . . .	3-26
Plug-In Display Modes . . . . .	3-26
Viewing Current Inserts (Insert Mode) . . . . .	3-26
Assigning a Plug-In or Hardware I/O Insert (Assign Mode) . . . . .	3-27
Editing Plug-In Parameters (Parameter Mode) . . . . .	3-27
<b>Soft Keys . . . . .</b>	<b>3-29</b>
Automation Enables . . . . .	3-29
Automation Modes . . . . .	3-29
Edit Tools Menu . . . . .	3-30
Edit Modes Menu . . . . .	3-30
Status/Group Menu . . . . .	3-30
Function Keys . . . . .	3-31
EDIT Menu . . . . .	3-31
SSL Menu . . . . .	3-31
<b>Working with DAW Automation . . . . .</b>	<b>3-33</b>
Automation Enables . . . . .	3-33
Automation Modes . . . . .	3-33
TRIM Mode . . . . .	3-33
Automation Status Display . . . . .	3-34
Suspending Automation . . . . .	3-34
Writing Automation (Write to Start, End or All) . . . . .	3-34
Automating Cuts . . . . .	3-35
Automating Pans and Sends . . . . .	3-35
Automating Plug-Ins . . . . .	3-35
<b>Mackie Control (MCU) Emulation . . . . .</b>	<b>3-37</b>
Mackie Control Emulation Advantages . . . . .	3-37
Implementation . . . . .	3-37
Mackie Function Control Overview . . . . .	3-39
The Logic Template . . . . .	3-40
Nuendo/Cubase Template . . . . .	3-42

# Section Index

## A

Audition	3-20
Automating Cuts	3-35
Automating Plug-Ins	3-35
Automation	3-33
Automation Enables	3-29, 3-33
Automation Modes	3-29, 3-33

## B

Banking	3-7
Bypassing	3-28

## C

Channel Fader	3-11
Channel Mode	3-14

## D

DAW 2	3-3
-------	-----

## E

Edit	3-13, 3-30
EDIT Menu	3-31
Edit Modes	3-30

## F

Flipping Send Levels	3-15
Footswitch	3-21
Function Keys	3-31

## H

HUI	3-7
-----	-----

## L

Layers	3-3
Logic	3-40

## M

Mackie Function Control	3-39
Master Control Panel	3-7
MCU	3-37
Meters	3-11
Modifier Buttons	3-8
Motion Control	3-19
Muting a Send	3-15

## N

Nuendo	3-42
Nuendo Control Screen	3-44
Numeric Keypad	3-23

## O

Output	3-17
--------	------

## P

Paging Buttons	3-25
Pan Mode	3-14
Plug-In Editor	3-25
Plug-In Parameters	3-27

## R

RDY	3-39, 3-43
REC	3-11
Record Ready	3-13
Record Safe	3-13

## S

Scrub	3-22, 3-23
SEL	3-39, 3-43
Select	3-12
Select Mode	3-14
Selecting a DAW Channel	3-26
Selection Mode	3-21
Send Mode	3-15
Send Routing	3-17
Setting Pre and Post Roll	3-20
Shuttle	3-22
Soft Keys	3-29
Solo	3-12
SSL Menu	3-31
Status/Group	3-30
Suspending	3-34

## T

Timecode	3-26
Transport Control	3-41
Transport Controls	3-19
TRIM	3-33

## U

Utility Buttons	3-8
-----------------	-----

## V

V-pot Sensitivity	3-28
V-pots	3-5, 3-14

## W

Writing Automation	3-34
--------------------	------

## Z

Zoom	3-21
------	------

---

*This page is intentionally almost blank.*

---

---

## Section 3: DAW Control

### Introduction

When connected to a Digital Audio Workstation that supports the HUI or Mackie Control Universal (MCU) control protocols, the Duality Fuse console becomes a powerful digital workstation control surface, giving direct access to the most important controls within the DAW. The console faders can be used to control the workstation faders and sends, the channel V-pots can be used to control pans, sends and I/O functions, and the Master Control Panel and plug-in controller provide easy access to a range of other parameters.

Duality Fuse can connect to two DAWs simultaneously, enabling more complex multi-workstation sessions to be run without leaving the listening position.

For an up to date list of compatible DAW applications please visit: <http://www.solidstatelogic.com>. This section of the manual is largely based on use with Digidesign's Pro Tools package, with supplementary pages for other packages, whose functionality will depend on their implementation of the HUI or MCU control protocols.

---

*Duality Fuse communicates with connected DAWs using MIDI ports – either MIDI over Ethernet (ipMIDI) or the physical MIDI ports located on the rear of the console. The separate Console Installation and Setup Guide details wiring and software installation for connecting via MIDI over Ethernet or conventional MIDI ports, and also details workstation configuration.*

---

### DAW Controller Features Summary

- Direct access to all major DAW mixing, editing and automation parameters
- MIDI connections over Ethernet
- Direct control of plug-in settings
- Integral colour TFT display with dedicated control buttons
- High resolution rotary encoder (V-pot) on every channel provides control of DAW pans, sends and I/O routing, and for MCU compatible applications, Plug-ins and Instruments
- High quality motorised faders to write/replay level moves in your DAW
- Simple switching between console layer and DAW control layer
- Full remote control implementation
- Operation independent of platform or application

## Console Focus

The console can be selected to one of two important modes using the Console Focus button (8), located on the Master Control Panel. This switches the channel meters, faders, solo and cut buttons between control of the analogue signal path and the DAW. When the Console Focus button is illuminated, Duality Fuse is in 'Analogue Focus Mode'. When the Console Focus button is not illuminated, Duality Fuse is in 'DAW Focus Mode'. This section describes operation of the console in DAW Focus Mode.

*Note that channel meters can be locked to either the analogue or DAW metering via the **METERS** soft keys on the monitor panel: **DAW** locks the channel meters to the DAW layers, and **Anl** locks the channel meters to the analogue channels.*

### Analogue Focus Mode

The channel faders control the channel audio output level for that fader. The channel meters indicate analogue input/output levels for that channel. The channel V-pots are available to control DAW parameters.

### DAW Focus Mode

The channel faders control DAW fader levels. The meters indicate DAW track levels. The channel V-pots are available to control other DAW functions such as pan or send level.

### Virtual 'In-line' Mode

When the console is in DAW Focus Mode, analogue level control can be assigned to the V-pots by pressing the **CHANNEL** button (1) on the Master Control Panel.

In Analogue Focus mode, the converse occurs with the V-Pots controlling the DAW faders levels. In either Focus mode, the V-Pot switch acts as a 'Fader Flip' reversing the assignments of the V-Pot and Fader. This mode emulates a traditional In-Line architecture with the DAW console as a fully automated and instantly resettable monitor mixer.

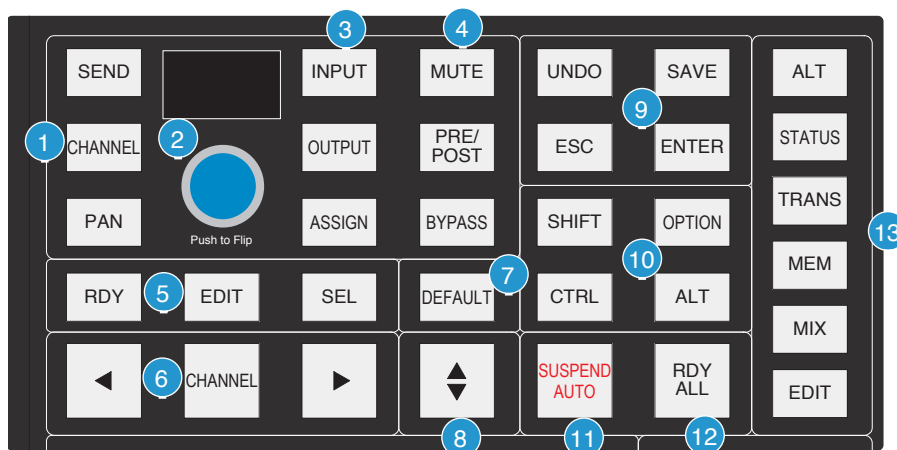

## DAW Layers

Duality Fuse can connect to two DAWs when connected using ipMIDI, and these are controlled from the two virtual 'layers'. Control operations performed on the Duality Fuse control surface will then affect whichever DAW is assigned to the currently selected layer.

To switch between the two DAW layers, press the **DAW 2** button, located beneath the Eyeconix button in the Monitor Controls area of the Centre Section (see below). Alternatively, go to **SSL / DAW** and choose either **DAW1** or **DAW2** to make it the currently selected layer.

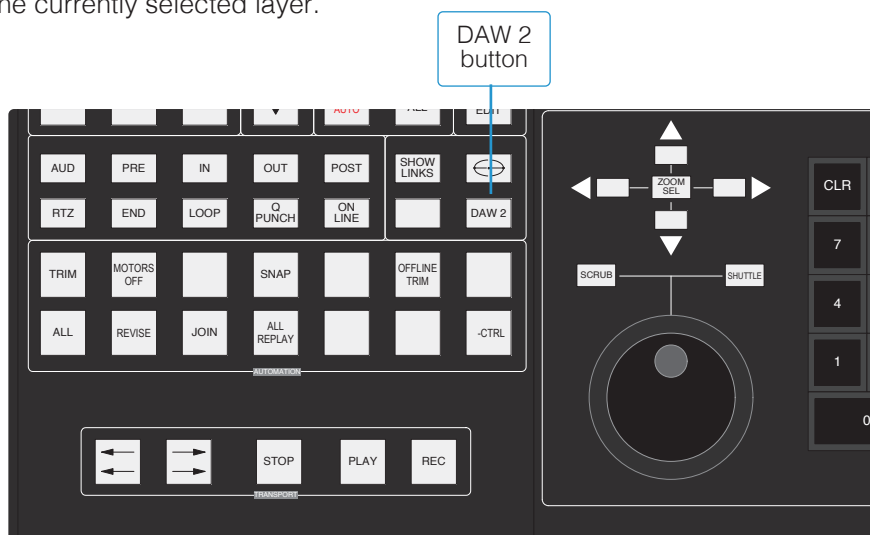

When the desk is in DAW Focus then the console controls will only effect the selected DAW.

---

## Connecting Duality Fuse to DAWs

---

*Please refer to the separate Duality Fuse Installation and Setup Guide for additional information concerning the connection of the DAW computer.*

---

Duality Fuse communicates with connected DAWs using MIDI ports – either MIDI over Ethernet (ipMIDI) or the physical MIDI ports located on the rear of the console. This is selected in **SSL / Misc / Setup / MIDI connects via**.

A number of items in the **SSL / Misc / Setup** menu, accessed via the centre section TFT, are concerned with DAW interconnection.

To change a setting, use the left hand V-pot to select the item, then press the V-pot to enter adjustment mode. Turn the V-pot to the desired setting and press it a second time to save the setting to non-volatile memory.

- DAW 1 Jog wheel sends:** Define the control data sent by the jog wheel for HUI DAWs. Normally the Jog Wheel has no action unless Scrub or Shuttle are enabled. The Nudge option allows the Jog Wheel to scroll through the session Timeline using the nudge (+/-) commands. Options are Jog / Nudge (40 / 20 / 13 / 10 / 8 / 6 / 5 per revolution). The Scroll action depends on the nudge value set in Pro Tools and the number of commands sent per a jog wheel revolution; adjust to taste.
- First physical channel DAW 1:** Select the console channel number that is controlling the first DAW track number for DAW 1.
- Channel Count DAW 1:** Select the total number of channels dedicated to DAW 1 control. Options are 8 to 48 in steps of 8 (32 channels max for HUI Controlled DAWs). If you change these figures, you will need to change the number of controllers assigned in the DAW.

---

*Note that these entries also exists for DAW 2 where applicable.*

---

- Single Layer:** Allows both DAWs to appear on different channel ranges within DAW layer 1. Ensure that the channel range for DAW 2 starts after the range for DAW 1.

---

*Note that changes to any of these settings will require a console reboot before they take effect: hold down the **Restart** softkey and press the **Confirm** softkey which appears to its right.*

---

Refer to your DAW manual for information on how to configure its software. Once configured and connected, communication with the DAW will be initialised, and the level of Duality Fuse's channel faders, rotary controls and master functions will be set to match the DAW controls (provided you are 'DAW Focus' mode).

## DAW Control Operations

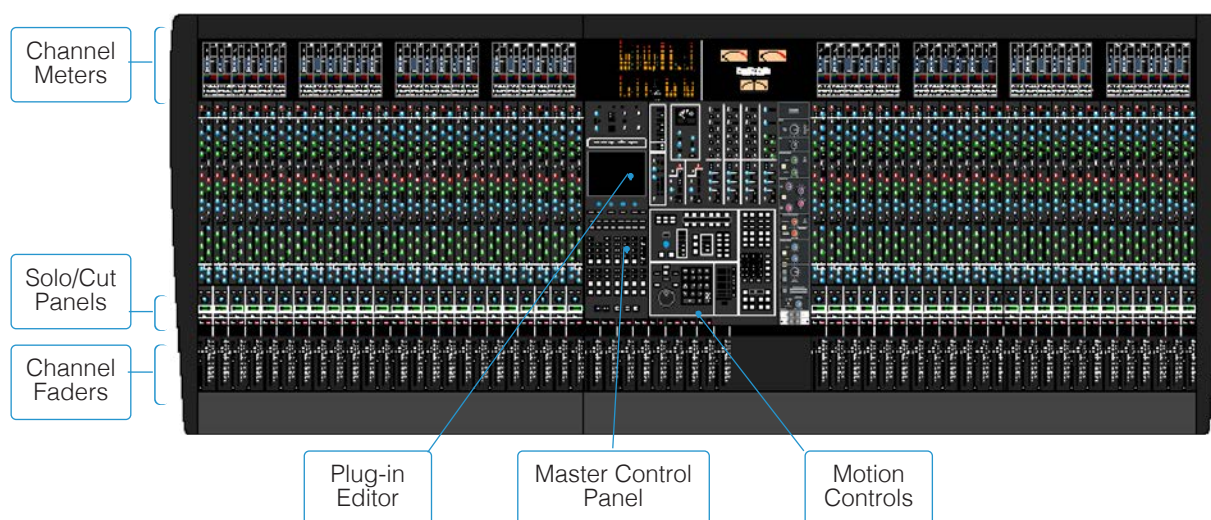

Duality Fuse's faders, and its Solos and Cuts panels, can be switched between controlling the analogue audio signal path and the DAW by pressing the Console Focus button . The Motion Controls, Master Control Panel and Plug-in Editor always control the DAW. The illustration above indicates those console elements that relate directly to a DAW in 'DAW Focus Mode'.

### V-pots

Each channel has a continuous rotary control or 'V-pot'. The Plug-in Editor (HUI Mode only) has four V-pots for control of plug-in parameters.

*This page is intentionally almost blank.*

## The Master Control Panel (HUI Mode)

The Master Control Panel contains a mixture of master functions and modifier buttons for DAW control:

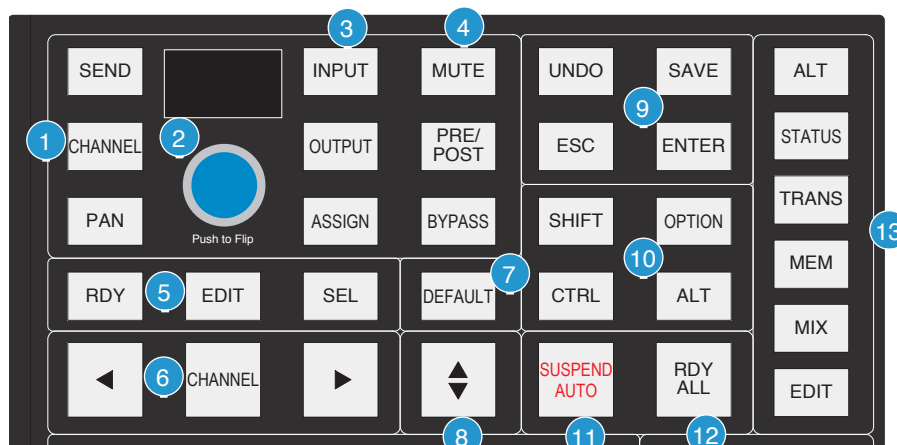

### Channel Banking Controls (6)

Duality Fuse can have up to 96 touch sensitive moving faders. However, you can only have a maximum of 32 faders assigned to DAW control in HUI mode, as Pro Tools only supports 4 HUI controllers, giving a maximum of 32 faders. If the DAW session has more tracks than this, Duality Fuse can 'bank flip' its faders to control any number of virtual faders within the DAW.

To flip the console's faders to the next set of DAW faders, press the right bank button. To flip back to the previous set, press the left bank button. Any number of virtual faders can be controlled from Duality Fuse using the banking buttons.

To scroll the faders one at a time, press the **CHANNEL** button (located between the two banking arrow buttons) followed by the left or right banking buttons; the **CHANNEL** button will light to indicate it is in 'Channel' mode. Press the **CHANNEL** button once more to switch back to 'Bank' mode.

### DAW Window Buttons (13)

This group of buttons provides instant access to the various windows within the DAW. Press them once to display or hide the relevant menu:

<b>ALT</b>	Opens or closes the floating window for the currently selected plug-in
<b>STATUS</b>	Opens or closes the Session Setup window
<b>TRANS</b>	Opens or closes the Transport window
<b>MEM</b>	Opens or closes the Memory Locations window
<b>MIX</b> and <b>EDIT</b>	Bring that window to the foreground. The button lights to show the currently active window

## DAW Utility Buttons (9)

This group of four buttons provide shortcuts to useful functions on the DAW.

**SAVE** will light when unsaved data is present. Pressing it once will cause the **SAVE** button to flash. A second press will save the Pro Tools session. Press **ESC** to cancel a pending save.

The **UNDO** button will light if undo is available, and flash if redo is available. Press the **UNDO** button to undo the last function and press **ALT + SHIFT + UNDO** to redo the last function.

**ENTER** duplicates the function of the ENTER key on the computer keyboard.

**ESC**(ape) duplicates the function of the ESC key on the computer keyboard.

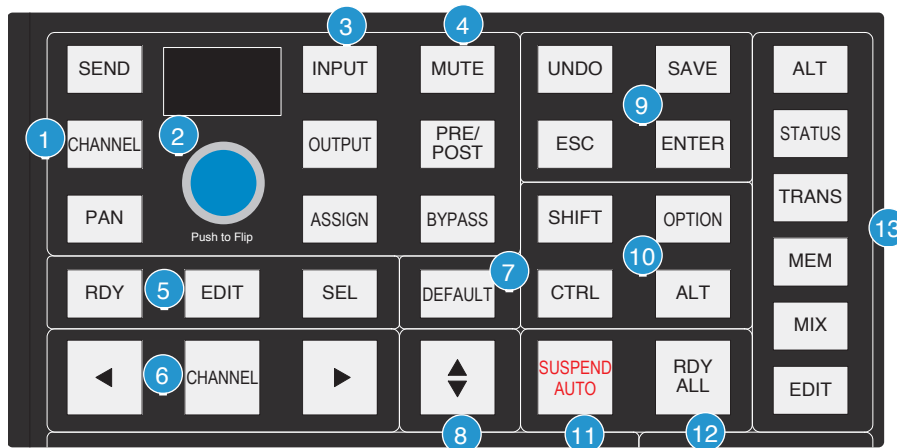

## Modifier Buttons (10)

These buttons modify the function of other buttons, and their practical use is detailed under the relevant topics in this section. For your information:

**OPTION** typically changes the function of a single button to affect all similar buttons. Thus holding down **OPTION** and pressing a channel **CUT** button will cut all DAW channels. It is a direct equivalent of a current Mac keyboard Option (⌘) key. The additional alt label found on this key refers to its use in Unix and Windows environments.

**SHIFT** allows selection of multiple objects or controls. It is a direct equivalent of the computer keyboard shift key.

**ALT** increases the resolution of rotary controls and inverts switch selections when held down. It is the direct equivalent of the Command (⌘) key on a current Apple keyboard.

**CTRL** disengages grouping when held down. It is a direct equivalent of the Mac keyboard Ctrl key.

*Although on the surface confusing, the **OPTION** and **ALT** keys are labelled according to the definitions in the Pro Tools HUI operating instructions which correspond to key cap labels on legacy mac keyboards. We have retained this convention to avoid confusion when following the many modifier key short cuts documented in the Pro Tools guide to MIDI controllers.*

## The Default Button (7)

Faders, pans and sends can be reset to their default values using the **DEFAULT** button:

### Resetting Pans

Select the **PAN** button on the Master Control Panel, and all Duality Fuse's V-pots become pan controls. Hold the **DEFAULT** button while pressing the V-pot on the channel you wish to reset. Hold down **OPTION** and press **DEFAULT** followed by the V-Pot switch to perform a reset across all pans.

### Resetting Faders

Hold the **DEFAULT** button while pressing the **SEL** (Select) button on the channel you wish to reset. Hold **SEL** **OPTION** and press **DEFAULT** followed by the SEL switch to perform a reset across all faders.

### Resetting Sends

Select the **SEND** button on the Master Control Panel. Turn the Master V-pot to scroll through the list of available sends. Hold the **DEFAULT** button while pressing the channel V-pot on the channel you want to reset. Hold down **OPTION** and press **DEFAULT** followed by the V-Pot switch to perform a reset across all sends.

### Resetting Plug-ins

Hold the **DEFAULT** button and press the Plug-In Editor **COMPARE** function. The plug-in default value is either the factory setting or user setting determined within the DAW.

---

*This page is intentionally almost blank.*

---

## Channel Functions

In DAW focus mode, the channel meters, faders and part or all of the Solo and Cuts panels control the DAW and display its status.

### DAW Meters

In DAW focus mode, Duality Fuse's channel meters flip to a stereo mode to indicate the level of the DAW signal path. Mono tracks are displayed on the left meter only.

The meters duplicate the function of meters within the DAW, and show the same information. They also follow DAW pre or post fader meter settings, as set within the DAW.

#### Status Indicators

The meter shows the status of the corresponding DAW track.

**REC** flashes when the track is in record ready and lights when the track is in record.

**EDIT** indicates that the track is selected for editing with the plug-in controller.

#### Multi-channel Metering (TDM Systems Only)

Multi-channel metering can be displayed by pressing **OPTION + SOLO** on a selected multi-channel track. The next two stereo meters are used to show the additional information. Normal metering functionality resumes after deselecting the **SOLO** function.

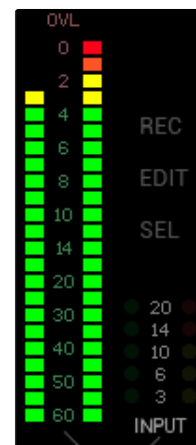

### Channel Fader

The channel fader can control any virtual DAW fader including Channel, Master, Auxiliary, MIDI tracks or Instrument tracks. The calibration of the fader will depend upon the DAW (please refer to your DAW manual for more details). Pressing **ALT** will display the gain of the DAW fader on the fader scribble strip when you move the fader.

#### Fader Grouping

Channel faders will follow any grouping enabled within the DAW. Faders can be disengaged from a fader group simply by holding down the **CTRL** button or by touching one fader in a group while adjusting another fader's level. Relative fader levels are maintained upon release of the fader.



## Channel Solo and Cut Panels

### Channel V-pot

Each channel has a continuous rotary control or V-pot. This can be used to control send levels and panning, and to assign input, output and send routing. See the following pages for more details.

The V-pot includes a push switch that is used (depending on the centre section mode) to select sends to be pre or post fade, to mute sends and to confirm I/O selections. Again, see the following pages for more details.

### Solo and Cut Buttons

Two sets of **SOLO** and **CUT** buttons are provided on each channel. The upper set is associated with the signal path controlled by the channel V-pot, and the lower set with the signal path under fader control. Thus in Analogue Focus mode, and with **CHANNEL** mode selected, the lower set of buttons control the analogue path and the upper set control the DAW channels. Changing to DAW Focus reverses this.



One easy way to tell if you are soloing a Duality or DAW channel is that channels cut by a Duality solo have a solid lit **CUT** button, and channels cut by a DAW solo have flashing **CUT** buttons.

Holding down **OPTION** and pressing a channel **SOLO/CUT** button will select/deselect that function across all channels. If channels are already soloed, then this action will turn off all solo buttons, providing a quick way to clear solos.

### Solo Isolate

Holding down **ALT** and pressing a channel **SOLO** will put a channel into 'Solo Isolate' mode. This prevents that channel from being cut when a **SOLO** is activated on another channel. This is particularly useful for FX return tracks.

### Channel Select Button

The channel **SEL** button can function as a channel select button, a track record enable or a plug-in edit enable button, depending on the mode selected on the Master Control Panel. See over the page for more details.

### Scribble Strip Displays

When a Duality channel fader is controlling a DAW fader level, the channel scribble strip will indicate a four character version of the DAW channel name. When controlling the analogue channel it displays the number of the fader, eg. 'FADR25' or the six character name entered from the Duality remote application.

The scribble strip can also display other information such as: automation status, grouping information, monitor information, input/output routing, send routing, send pre/post information, fader level display, and pan position (see the following pages for details). An indication of the selected function is provided in these other modes — Pan, ASGN etc.

## Channel SEL Button — Record Ready/Edit/Select

The function of the channel **SEL** button depends on the mode selected by the centre section **RDY**, **EDIT** and **SEL** buttons (5) on the Master Control Panel.

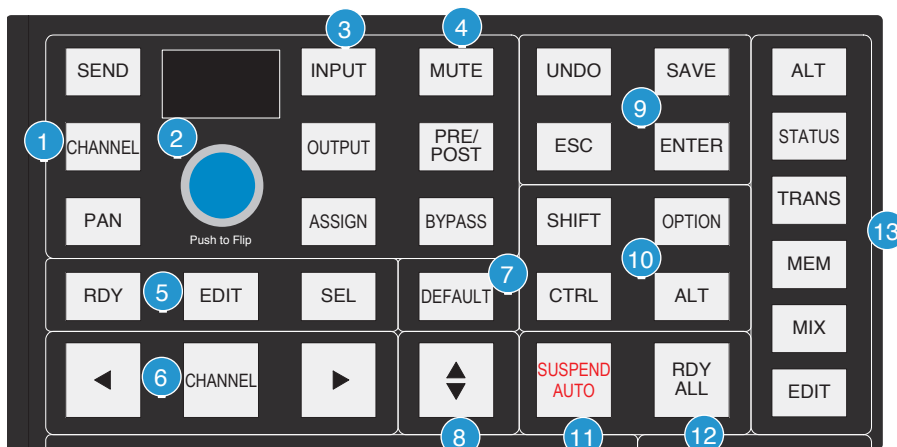

### Record Ready Mode

When **RDY** is selected, all the channel **SEL** buttons become Record Ready buttons. Pressing a channel **SEL** button puts that DAW track into Record Ready (provided that the DAW track has an input routed). The **REC** tally in the channel meter display flashes to show that the track is in ready.

### Ready All

Track arming can be set or cleared across all channels by using the master **RDY ALL** button (12). This button flashes if any DAW tracks are in Record Ready. Pressing this button while it is flashing will clear all track arming.

### Record Safe

To put a DAW track into Record Safe (so it cannot be selected to Record Ready) hold down **ALT** and press the channel **SEL** button. Hold down **ALT + OPTION** then press any **SEL** button to select all tracks to Record Safe.

## Edit Mode

With the **EDIT** button selected, a channel **SEL** button can have a number of different functions:

As long as the Master Control Panel **BYPASS** button is not selected, pressing a channel **SEL** button assigns the Plug-in Editor to that channel. The **EDIT** flag on that channel's meter display will light to confirm that this is the **EDIT** channel (see **Plug-in Editor** for more details). A double press on the **SEL** button will select the first plug-in on that channel for editing. Successive double presses will select the next plug-in on that channel.

Selecting the **BYPASS** button (4) on the Master Control Panel changes the channel **SEL** buttons to **BYPASS** buttons. Pressing a channel **SEL** button will bypass all plug-ins on that channel. The channel meter display's **EDIT** flag will light to show that all plug-ins are bypassed.

Note that due to changes in Pro Tools software following the release of the Avid Command 8 control surface the EDIT key function is only available from the first 8 channels – to select plugins on other channels, use the mouse (or page the channel to faders 1 – 8).

## Select Mode

With the **SEL** button (5) on the Master Control Panel selected, all the console's channel **SEL** buttons become track select buttons. They perform the same function as clicking on a channel in the DAW screen display.

A double click on a **SEL** button will open the channel naming pop-up for that channel. Multiple channels can be selected by holding down the **SHIFT** button while selecting further **SEL** buttons or by holding down the first **SEL** button you pressed while you select more channels. Note that this latter method only works within blocks of channels corresponding to a single HUI interface.

Hold down **OPTION** and press any **SEL** button to select all channels. Hold down **ALT** and press any **SEL** button to invert the state of all select buttons.

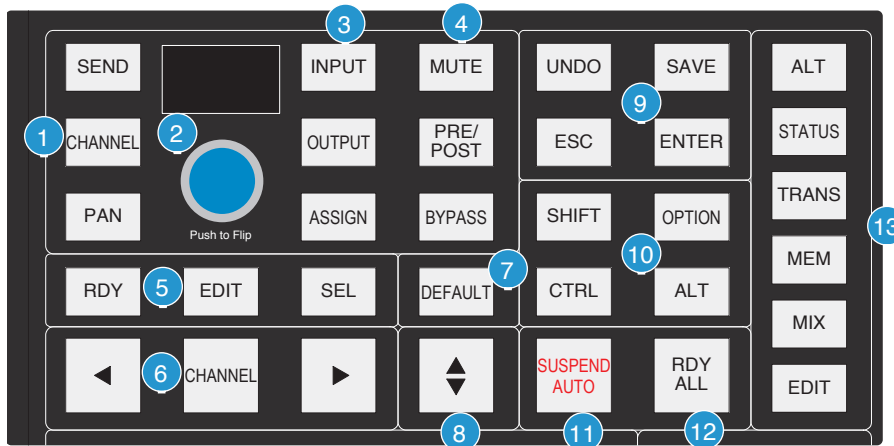

## Working with the Channel V-pots

The channel V-pots can control the DAW's channel pan, send (aux) levels and pan, routing assignment and analogue audio levels. Each V-pot also has a switch which is activated by pushing down on the V-pot.

The channel V-pot function is selected on the Master Control Panel by the Master Send V-pot (2) and six associated buttons (1) and (3). The scribble strip above the channel V-pots shows which function is currently selected. A further two buttons (**PRE/POST** and **MUTE**) change the function of the V-pot push switches.

### Pan Mode

Select the **PAN** button on the Master Control Panel, and the channel V-pots become pan controls for the DAW. The V-pot scribble strip displays **Pan**.

Pressing the **PAN** button a second time (it flashes in this mode) allows you to access a second pan control for stereo channels, according to the DAW configuration. The V-pot scribble strip displays **Pan R** in this mode. Press the **PAN** button again to return to normal pan mode. Holding down **ALT** displays a pan's numeric value on the channel scribble strip as you adjust the control.

### Channel Mode

Select the **CHANNEL** button on the Master Control Panel, and the channel V-pots control the analogue gain of the channel strip. The V-pot scribble strip will display the analogue fader number (eg. 'FADER').

Switching to Analogue Focus mode will swap the analogue gain and the DAW gain between V-pot and channel fader. Individual channels can be swapped by pressing the channel V-pot.

## Send Mode

Select the **SEND** button on the Master Control Panel, and the V-pots become level controls for any sends or aux send levels within the DAW.

The Master V-pot (2) selects which of the available sends (A – E or 1 – 5) is being controlled by the channel V-pots. The selected send is shown in the display window above the Master V-pot (and on the channel V-pot scribble strip). The channel scribble strips show the name of the currently selected send. Turning a channel V-pot will alter the level of the selected send from that channel. Holding down the **ALT** button allows you to make fine adjustments to the gain. See over the page on how to use faders to set send levels.

## Setting Sends Pre/Post Fader

When working with sends it is useful to be able to flip a send between pre and post fader. If necessary, first select the **PRE/POST** button (4) on the Master Control Panel. Pushing a channel V-pot will now switch the selected send on that channel between pre and post. The green LED below the V-pot lights to show **PRE** is selected.

To change mode on all channels, press and hold the Master Control Panel **OPTION** button then press any channel V-pot. All channels will switch to pre or post.

## Muting a Send Output

To mute a send output, select the **MUTE** button (4) on the Master Control Panel and push the channel V-pot. The LED below the channel V-pot will light to show the channel is muted. To mute or un-mute all channels, press and hold the **OPTION** button then press any channel V-pot.

## Flipping Send Levels to the Faders

To flip send levels from the V-pots to the channel faders, press the Master V-pot (2) — hence **Push to Flip!** The channel faders now control send levels and the fader **CUT** button will mute a send. The channel V-pot controls panning on stereo sends.

In this ‘flipped’ mode, **PRE/POST** mode is automatically selected for the V-pot switches, so pushing a V-pot will toggle the send pre/post on that channel. The LED below the V-pot lights to show **PRE** is selected.

Note that the fader **SOLO** button will still solo the channel, not the send.

---

*This page is intentionally almost blank.*

---

## Input, Output and Send Routing

The channel V-pots can also be used to assign signals to inputs, outputs and the aux sends of a DAW:

### Viewing Input, Output and Send Routing

The input, output or send routing for all DAW channels can be displayed on the channel scribble strip by holding down the **INPUT**, **OUTPUT** or **SEND** button (3) on the Master Control Panel and using the Master V-pot to select which of the available sends you wish to display.

### Setting input, Output and Send Routing

To make or change an input, output or send assignment:

1. Select **ASSIGN + INPUT** or **OUTPUT** or **SEND** (3) on the Master Control Panel.

---

*When using **SEND**, use the Master V-pot to select the send you wish to change*

---

2. The V-pot scribble strip will now read **ASGN** and the fader scribble strip will indicate the current routing for the DAW channel.
3. Turn a channel V-pot to scroll through a list of available DAW inputs or outputs (names are derived from the DAW I/O settings, not Duality SE). The list will appear in the channel scribble strip. The LED below the V-pot will flash.
4. Push the V-pot knob to select the current assignment; the LED will become solid and a '✓' symbol will appear in front of the assigned signal (for example, 'OUTB-4').
5. Press the **ASSIGN** button once more to exit assign mode. This will also commit any changes you have made, that have not been confirmed by pressing the V-pot.
6. Pressing **ESC** at any time will abort the assignment process.

#### Assigning Signals to Multiple Channels

Holding down **OPTION** then pressing any channel V-pot will assign that channel's input to all channels. Holding down **SHIFT + OPTION** will assign that channel's input to all selected channels. Select **SEL** mode on the Master Control Panel then press the **SEL** buttons on the channels you wish to route to.

Holding down **OPTION + ALT** then pressing a channel V-pot will incrementally route that channel's input to all channels. For example, selecting input 1 as the input to channel 9, then holding down **OPTION** and **ALT**, before pressing the channel 9 V-pot, will route input 1 to channel 9, input 2 to channel 10, input 3 to channel 11 and so on across the entire DAW.

Holding down **SHIFT + OPTION + ALT** will incrementally route that channel's input to all selected channels. Select **SEL** mode on the Master Control Panel then press the **SEL** buttons on the channels to which you wish to route.

#### Assigning a Channel to Multiple Outputs

Hold the **CTRL** button and select another output. The currently assigned output will have a '✓' symbol in front of it (for example, 'OUTB-4'), and other added outputs will have a '+' (for example 'OUTB-5') until you assign it. In the scribble strip, an '⊘' symbol indicates that an item is inactive (ie. routed but muted). The '⊞' symbol indicates that more than one output is assigned, and at least one of those is inactive.

*This page is intentionally almost blank.*

## Motion Control

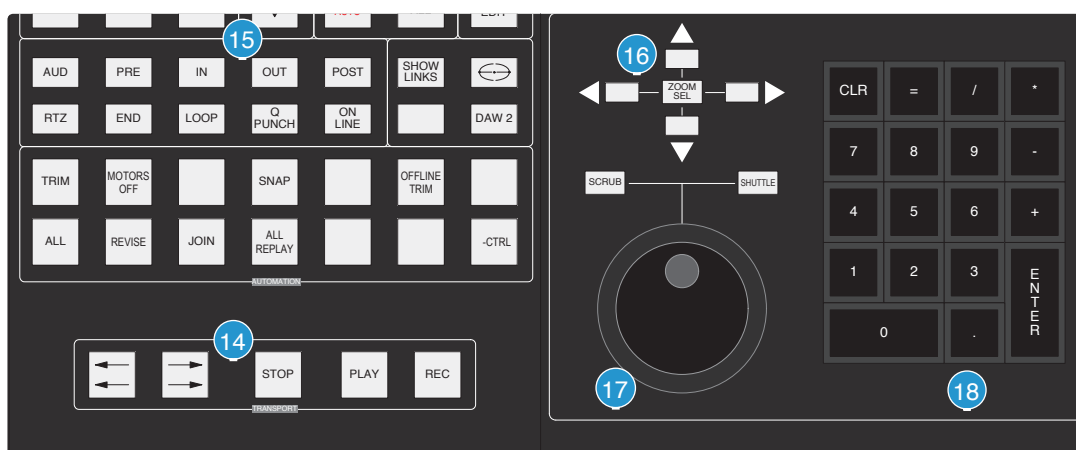

### Basic Transport Controls (14)

Dedicated transport controls are provided for direct control of the DAW:

<b>REWIND</b>	Press and hold to rewind the DAW (increment depends upon DAW Display mode)
<b>FAST FORWARD</b>	Press and hold to fast forward the DAW (increment depends upon DAW Display mode)
<b>STOP</b>	Stops playback or recording
<b>PLAY</b>	Commences playback from the current cursor position or the last locate point, depending on DAW settings
<b>RECORD</b>	Engages DAW recording for currently armed tracks

### Additional Transport Controls (15)

<b>PRE</b>	Toggles the DAW pre-roll function. See next page for setting pre-roll time
<b>POST</b>	Toggles the DAW post-roll function. See next page for setting post-roll time
<b>IN</b>	Captures the current DAW position as the Start edit time
<b>OUT</b>	Captures the current DAW position as the End edit time
<b>RTZ (Return-To-Zero)</b>	Returns the playback cursor to the Session start time
<b>END (Go-To-End)</b>	Moves the playback cursor to the Session end time
<b>LOOP</b>	Toggles Loop mode on/off (hold down <b>CTRL</b> for Loop Record mode)
<b>Q PUNCH</b>	Toggles the DAW Quickpunch recording status on/off
<b>ONLINE</b>	Puts the DAW Online for synchronisation

See next page for details of the **AUD** button.

## Other useful transport modes

Half-speed Playback	<b>SHIFT + PLAY</b>
Abort Current Record Pass	<b>SHIFT + STOP</b>
Cycle through Record Modes (Normal, Quickpunch, TrackPunch, Loop)	<b>CTRL + RECORD</b>
Cycle through Machine Control Masters (accessible via the transport window)	<b>CTRL + ONLINE</b>
Link or Unlink the Edit and Timelines	<b>SHIFT + / (backslash)</b>

## Setting Pre and Post Roll (15)

Hold down **ALT** and press the **PRE** or **POST** button to highlight the left hand numeric field of the **pre-roll** or **post-roll** time window; the time is displayed on Duality's TFT screen in place of the DAW's timecode position. The selected numeric field will flash; use the navigation left/right arrow buttons (16) to select a different numeric field if required, then enter a value on the numeric keypad (18) or use the up/down arrow buttons (16) to increase or decrease the selected field.

Press **ENTER** on the numeric keypad (18) to confirm the time. The numeric keypad's **CLR** button can be used to clear the selected time.

## Setting start (In) and end (Out) Times (15)

Hold down **ALT** and press the **IN** or **OUT** button to highlight the left hand numeric field of the start or end time window. The time is displayed on Duality's TFT screen in place of the DAW timecode position. The selected numeric field will flash; use the navigation left/right arrow buttons (16) to select a different numeric field if required, then enter a value on the numeric keypad (18) or use the up/down arrow buttons (16) to increase or decrease the selected field.

Press **ENTER** on the numeric keypad (18) to confirm the time. The numeric keypad's **CLR** button can be used to clear the selected time.

## Audition (15)

This function allows the **IN**, **OUT**, **PRE** and **POST** points to be checked. Press the **AUD** button, then press either the **PRE**, **IN**, **OUT**, or **POST** button. Press the **AUD** button again to cancel the function.

**PRE** Plays from the **pre-roll** point to the selection **start** point

**IN** Plays from the selection **start** point for the **post-roll** time

**OUT** Plays from the **end** point less the **pre-roll** time to the **end** point

**POST** Plays from the selection **end** point for the **post-roll** time

**ALT + OPTION + PRE** or **IN** Plays from the selection **start** point less the **pre-roll** time to the selection **start** time plus the **post-roll** time

**ALT + OPTION + POST** or **OUT** Plays from the selection **end** point to the selection **end** point plus **post-roll** time.

## Footswitch Control

Duality Fuse has two 1/4" jack footswitch connectors on the rear of the console. These are intended for hands-free access to essential transport functions:

Footswitch Control 1 either plays or stops the DAW. Holding down **SHIFT** will abort a recording if in record, or initiate half-speed playback if stopped.

Footswitch Control 2 is used to activate or deactivate record mode. Holding **CTRL** while pressing the footswitch will cycle through record modes.

## Zoom, Navigation and Selection Modes (16)

The Motion Control area has a section with four cursor buttons and a **ZOOM/SEL** function that toggles the selection of three available modes: **Navigation Edit**, **Zoom** and **Select**.

Navigation Mode (Zoom/Sel button not lit)

In this mode the cursor buttons can be used to select a region or regions on the DAW screen.

The left and right buttons will snap to region/clip boundaries. The up/down buttons move the cursor to the track above or below respectively. Holding down the **SHIFT** modifier button will allow a selection to be extended in any direction. Holding the **OPTION** button allows the current selection point to be centred on the screen.

Holding **CTRL + Up/Down/Left/Right** cursor button allows you to change and extend the region/clip selection. Add **SHIFT** to the above combination to include either the previous or next region.

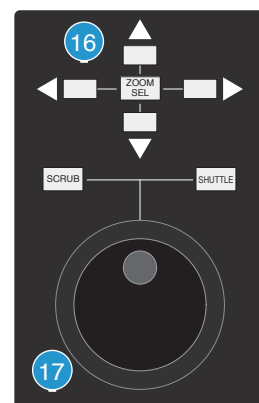

Zoom Mode (Zoom/Sel button lit)

The cursor buttons now become horizontal and vertical zoom controls for the edit/arrange window on the DAW.

Fixed edit/arrange zoom settings can be saved or recalled from Duality Fuse's numeric keypad:

To save a zoom setting — press **SHIFT** + numeric keypad number

To recall a zoom setting — press **OPTION** + numeric keypad number

Selection Mode (Zoom/Sel button flashing)\*

In this mode the cursor buttons provide a way to create and edit selections within the DAW program.

To create a selection, press and hold either the left or right cursor button and move the inner shuttle wheel to adjust the start or end point for the selection. The up and down cursor buttons will move the selection to the next track. Holding **SHIFT** and using the up/down buttons will allow the selection to be extended across multiple tracks.

Holding the left and right cursor buttons simultaneously, while scrubbing, retains the selection duration while moving the selection start point.

Pressing **OPTION + Up/Down** cursor button removes the upper or lowermost track from the selection.

---

\* Version 6 and below. HUI Selection Mode is not supported in current Pro Tools HD software.

---

## Scrolling Within a Window

To page scroll one page in either direction within a currently selected window (ie. Mix/Mixer or Edit/Arrange), press the **ALT + Up/Down/Left/Right** cursor button.

Holding down **OPTION** and **ALT** scrolls to the window boundary.

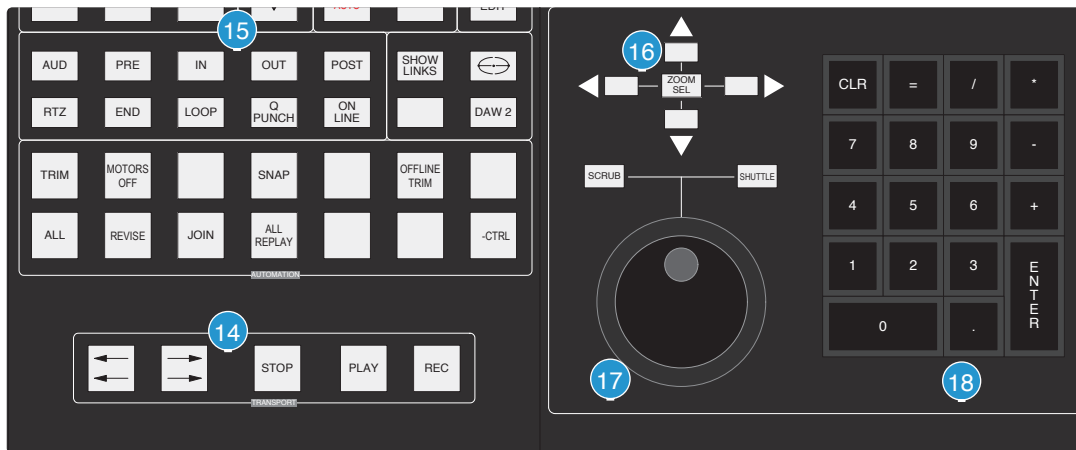

## Shuttle/Scrub Wheel (17)

A dual-concentric Shuttle/Scrub wheel is provided. It has a spring-loaded outer ring and a continuously variable inner wheel for DAW scrub and shuttle functions.

Provided the Nudge option has been enabled in **DAW 1 Jog wheel sends:** entry in the **SSL / Misc / Setup** menu, the inner wheel can be used to scroll through the session timeline, and to modify edit selections. This is achieved by sending nudge commands as the wheel is turned, with the number of nudge commands set from the setup menu (options are 40 / 20 / 13 / 10 / 8 / 6 / 5 per revolution). In conjunction with the nudge value set in the Pro Tools nudge menu, this sets the resolution or 'feel' of the scroll option and should be adjusted as required.

When DAW 2 is HUI controlled, there is a **DAW 2 Jog wheel sends:** menu entry.

Additional modes are enabled via the Shuttle and Scrub switches or directly from the outer ring.

### Shuttle Mode

With the DAW stopped, turn the wheel to activate shuttle mode. The outer rim will step through seven fixed shuttle speeds, while the inner controller is continuously variable.

To use the inner wheel as a shuttle control, press the **SHUTTLE** button above the wheel. The inner wheel now becomes a continuously variable shuttle control.

In HUI mode, with Scrub and Shuttle deselected, the inner wheel will send either nudge commands (+/-) or jog commands. Select to suit the DAW being controlled.

## Scrub Mode

Select a region to scrub within the DAW. Press the **SCRUB** button above the wheel. The inner wheel now becomes an analogue tape machine style scrub wheel.

### Using the Numeric Keypad to shuttle

Depending upon the configuration of your DAW system, the numeric keypad can be used to control shuttle speed and direction. Hold down the **CTRL** button followed by a number on the numeric keypad that represents the shuttle speed. The +/- buttons control the direction of shuttle.

To exit from shuttle mode press either the **STOP** or **ESC** button.

### Notes on Scrub and Shuttle Modes

The position at which the scrub/shuttle starts is derived from the current DAW selection or timeline position. Scrub/Shuttle mode can commence from the selection end point by holding down the **OPTION** button before you grab the shuttle wheel.

Holding down the **ALT** button will increase the resolution of the scrub/shuttle wheel.

When scrub or shuttle is active, many functions are suspended until you exit from scrub/shuttle mode. The following functions are available:

- Fader control, solo and cut buttons
- Scrub/Shuttle wheel functions
- Transport controls
- Enter button (to create marker/cue events)

Scrub/Shuttle will also control serial machines if the DAW is 9-pin enabled.

## Numeric Keypad (18)

The console's numeric keypad replicates the numeric keypad on a DAW keyboard. The primary use for this keypad is for saving and recalling Memory Locates and entering data values (please refer to your DAW manual for more details on keypad uses).

### Working with Markers/Memory Locations

To Enter a Marker/Cue point, press **ENTER**. To Recall a Marker/Cue point, press a number followed by the decimal point button (Numeric Keypad in *Classic* mode) or a decimal point followed by a number followed a decimal point (Numeric Keypad in *Transport* mode).

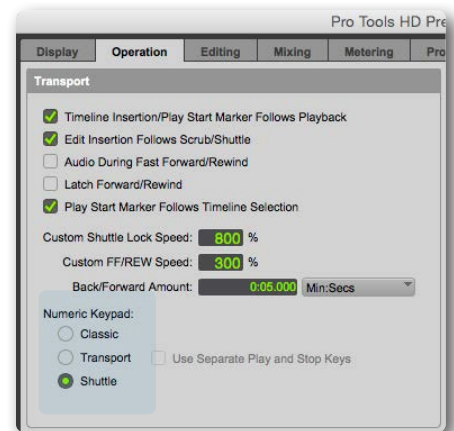

---

*The **ENTER** button on the keypad also works as a enter button for pop-up windows, duplicating the **ENTER** button on the Master Control Panel.*

---

---

*This page is intentionally almost blank.*

---

## Plug-In Editor

Duality Fuse comes with a powerful Plug-in Editor located in the console centre section. From here, plug-ins and hardware inserts can be assigned, and plug-in parameters can be edited.

### Plug-In Editor Display

The Plug-In Editor uses a high resolution TFT display, four V-pots and four soft buttons to control the parameters of any plug-in. The display is also used to show the position and status of the DAW, and to provide access to a range of paged menus.

The currently selected EDIT channel name is displayed at the top of the screen. Below are the plug-in control displays followed by transport status displays and a timecode display. At the foot of the screen are two rows of soft key menu selections



### Plug-In Editor Controls

Controls for the display are located just below the screen area. The four V-pots and associated in-line soft keys are mapped to the corresponding controls on the display. The V-pots also have push-push select switches that perform various functions.

The display also shows information from the DAW at the top of the editor display.

### Paging Buttons

The left/right paging buttons either page through available insert slots in **INSERT** mode, or plug-in parameters in **PARAMETER** mode (see below).

The far left and far right buttons directly below the V-pots provide a Page Down and Page Up facility respectively.



## Selecting a DAW Channel for Plug-In Control

Select **EDIT** mode on the Master Control Panel then use the channel **SEL** buttons to choose the channel you wish to edit. The **EDIT** flag in the channel meter will light. The DAW will highlight the selected channel and the currently selected plug-in. Press **ALT** to display the plug-in window.

Alternatively, select a channel by double clicking on one of the insert points in the Mix window.

---

*Note that due to changes in Pro Tools software following the release of the Avid Command 8 control surface the EDIT key function is only available from the first 8 channels – to select plugins on other channels, use the mouse (or page the channel to faders 1-8).*

---

*Note also: Bank switching channels leaves the Plug-In Editor with the channel assigned to it. The channel EDIT tally will show this.*

---

## Timecode/Bars & Beats/Samples Display

The on-screen timecode readout can be assigned to display either timecode (SMPTE/EBU), Feet/Frames, Bars/Beats or samples. This display will follow the setting selection made within your DAW. Please refer to your DAW manual for further details.

## Plug-In Display Modes

There are three display modes, **Insert**, **Parameter** and **Assign**, all of which are selected using the soft button **ASSIGN** and **INSERT/PARAM** buttons below the V-pots.

## Viewing Current Inserts (Insert Mode)

Press the **INSERT/PARAM** button till the **INSERT/PARAM** box reads **INSERT**; the Plug-in Editor is now in Insert mode. In this mode, the four V-pots represent four insert points on the selected channel. The currently assigned plug-ins are displayed above each V-pot. The name of the currently active plug-in will flash. Additional insert points can be displayed using the paging buttons.

The four V-pot push switches can be used to select an insert slot for editing or for plug-in assignment — see over.

## Assigning a Plug-In or Hardware I/O Insert (Assign Mode)

To Assign a Plug-in to a Channel Insert Point:

1. Press the **ASSIGN** soft button to enter assign mode; the on-screen box flashes to confirm this.
2. Press the V-pot corresponding to the insert slot that you want to route to a plug-in (use the paging buttons as necessary) then use the V-pot to scroll through the list of plug-ins and I/O slots; the displayed names are derived from the DAW.
3. To confirm the assignment either:
  - a. Press the **ASSIGN** button a second time. This will exit **INSERT** mode and switch the Plug-In Editor to **PARAMETER** mode to edit the last selected insert, or
  - b. Press the V-pot used to make the assignment. This will confirm the assignment and leave you in Assign mode for further assignments.

---

*Some DAW applications will not allow assignments to be made during playback or recording.*

---

### Assigning the Same Plug-in to All Channels

Follow steps 1 and 2 above to select a plug-in, then hold down the **OPTION** button before pressing the V-pot switch to assign that plug-in to all channels.

### Assigning The Same Plug-in to Selected Channels

To assign a plug-in to selected channels, select **SEL** mode on the Master Control Panel then choose the channels you wish to assign to by holding down **SHIFT** and pressing the channel **SEL** buttons.

Follow steps 1 and 2 above to select a plug-in, then hold down **OPTION + SHIFT** before pressing the V-pot switch to assign the plug-in to the selected channels.

## Editing Plug-In Parameters (Parameter Mode)

### Selecting a Plug-In to Edit

In **Insert** or **Assign** mode, press the plug-in V-pot for the insert you wish to edit or in **Insert** mode, select **Parameter** mode by pressing the **INSERT/PARAM** soft button. To exit from **Parameter** mode, press the **PARAM** soft key (if you want to edit a different plug-in) or the **ASSIGN** soft key (if you want to change assignment).

### Changing Plug-in Parameters

Once you have selected a channel and a plug-in for editing, the four V-pots and their switches control the on-screen parameters derived from the DAW plug-in. The names of the currently selected controls and their values are shown above the on-screen V-pots. The **PAGE UP** and **PAGE DOWN** buttons can be used to access all the plug-in controls.

### Hi-Resolution Parameter Display Mode

Holding down the **OPTION** button while editing a plug-in parameter will show a 9-character version of the parameter value at the top of the Plug-In Editor display.

---

*The **ALT** button can be used to open or close the plug-in/pop-up window at any time.*

---

## Comparing Your Changes

Pressing the **COMPARE** button allows you to compare any changes made to plug-in parameters with the values stored before editing. As soon as you change any parameter the **COMPARE** box will turn yellow. Pressing the **COMPARE** button toggles between the settings when you starting editing parameters and the current settings.

---

*Note that the plug-in window must be opened before this function becomes available.*

---

## Bypassing Plug-ins

The **BYPASS** button allows a plug-In to be toggled in/out of the signal path in **PARAM** mode. In **INSERT** mode, individual plug-ins can be bypassed by holding down the **BYPASS** button and pushing the V-pot that corresponds to the insert you want to bypass. The channel **SEL** button can be used to bypass all the plug-ins on a channel.

## V-pot Sensitivity

The Plug-in Editor's V-pots can be set to one of two modes: **Fixed** or **Velocity-sensitive**. In **Fixed** mode, turning a knob will range through the complete list of available parameters; this allows you to search through long lists very quickly. Holding down the **ALT** button enables a finer resolution scroll function. In **Velocity-sensitive** mode, the speed of scrolling is dependent upon how quickly you turn the V-pot. To toggle between the two modes press the **F5** button in the **Fkys** menu.

---

*Note that the channel V-pots only operate in Fixed mode.*

---

## Soft Keys

The Plug-In Editor panel includes an 8 x 8 matrix of soft keys that map to the 16 menu boxes at the bottom of the plug-in display.



The top row (buttons 1 – 8) allows selection of the labelled functions. Once pressed, a submenu will appear below. These items are selected using the second row of soft key buttons (9 – 16). The menus are ordered as follows:

### Automation Enables

AuEn	AuMo	EdTs	EdMo	StGr	Fkys	Edit	SSL
Fader	Pan	Plgin	Mute	Send	SnMute		

The Automation Enables (**AuEn**) globally engage or disengage automation for the following items: Faders, Pans, Plug-Ins, Mutes (cuts), Sends and Send Muting. See **Working with Automation** for more details.

### Automation Modes

AuEn	AuMo	EdTs	EdMo	StGr	Fkys	Edit	SSL
Trim	Latch	Touch	Write	Read	Off		

Automation Modes (**AuMo**) set the update mode for each channel or group of channels. See **Working with Automation** for more details.

## Edit Tools Menu

AuEn	AuMo	EdTs	EdMo	StGr	Fkys	Edit	SSL
Zoom	Trim	Select	Grab	Scrub	Pencil	Smart	

Edit Tools (**EdTs**) displays a list of available tools used by your DAW system. For example, with Pro Tools you can select the Zoom, Trim, Select, Grabber, Scrub Pencil and Smart Tool tools.

## Edit Modes Menu

AuEn	AuMo	EdTs	EdMo	StGr	Fkys	Edit	SSL
Shuffl	Slip	Spot	Grid				

Edit Modes (**EdMo**) displays a list of available edit modes used by your DAW system. Within Pro Tools you can select Shuffle, Slip, Spot and Grid modes.

## Status/Group Menu

AuEn	AuMo	EdTs	EdMo	StGr	Fkys	Edit	SSL
Auto	Mon	Phase	Group	Create	Susp		

The Status/Group (**StGr**) menu contains several useful functions including:

- Auto:** Displays, on the channel fader scribble strips, the automation status of all focused channel faders.
- Monitor:** Displays, on the fader scribble strip, the monitor status of all focused channels. Designations are as follows:
  - AUTO Auto input mode
  - INPT Input mode only
  - AUX Auxiliary input channel
  - MIDI MIDI channel
  - MSTR Master Fader
  - PHASE Not implemented
- Group:** Displays the grouping status of all focused channels on the console. A lowercase letter indicates that a fader belongs to that group. An uppercase letter indicates that the fader belongs to multiple groups, with the foremost group ID being displayed, eg. 'e' for groups b, c and e.
- Create:** To create a fader group for your DAW, select **SEL** mode on the Master Control Panel then hold down the **ALT** modifier key and press the **SEL** buttons on any channels you wish to group. Finally, press the **CREATE** button and a new group will be created.
- Suspend:** Fader/Mix groups can be suspended at any time by selecting **SUSPEND**; they are now disengaged from their respective grouping arrangements. Pressing **SUSPEND** a second time re-enables the groups.

## Function Keys

AuEn	AuMo	EdTs	EdMo	StGr	Fkys	Edit	SSL
F1	F2	F3	F4	F5	F6	F7	F8/Esc

The F-Keys (**Fkys**) menu gives access to the DAW function keys; these will vary between DAW applications. A standard configuration for Pro Tools is:

- F1** Peak Hold Clear for the Duality channel meters
- F5** Cycles **Fixed** or **Velocity-sensitive** modes for the V-pots
- F8** Escape

## EDIT Menu

AuEn	AuMo	EdTs	EdMo	StGr	Fkys	Edit	SSL
Capt	Sep	Cut	Copy	Paste	Delete		

The Edit (**Edit**) menu provides quick access to frequently used editing functions including Capture, Separate, Cut, Copy, Paste and Delete.

## SSL Menu

This menu is used to access additional optional features such as the Duality  $\delta$ -Control Automation System, A-FADA automation, and Total Recall. Information regarding these features will be found in the appropriate section of this manual.

---

*This page is intentionally almost blank.*

---

## Working with DAW Automation

Duality Fuse's touch sensitive moving faders can be used to write automation for the DAW faders. Most automation functions are enabled from the soft key matrix below the Plug-in Editor display screen. Menus are provided for Automation Enables, Automation Modes, Grouping and Editing functions.

*Note that automation data can usually only be written when the DAW is in Play, Half-Speed Play or Record.*

### Automation Enables

<b>AuEn</b>	<b>AuMo</b>	<b>EdTs</b>	<b>EdMo</b>	<b>StGr</b>	<b>Fkys</b>	<b>Edit</b>	<b>SSL</b>
<b>Fader</b>	<b>Pan</b>	<b>Plgin</b>	<b>Mute</b>	<b>Send</b>	<b>SnMute</b>		

The Automation Enables (**AuEn**) menu is used to globally engage or disengage automation for the following items: Faders, Pans, Plug-Ins, Mutes (cuts), Sends and Send Muting. Holding down the **OPTION** button and then pressing any of the submenu buttons will toggle automation on or off for all controls. The **Pan** automation enable includes both Channel and Send Pan.

### Automation Modes

<b>AuEn</b>	<b>AuMo</b>	<b>EdTs</b>	<b>EdMo</b>	<b>StGr</b>	<b>Fkys</b>	<b>Edit</b>	<b>SSL</b>
<b>Trim</b>	<b>Latch</b>	<b>Touch</b>	<b>Write</b>	<b>Read</b>	<b>Off</b>		

Several Automation Modes (**AuMo**) are available: **Write** (Wrt), **Touch** (Tch), **Latch** (Ltch), **Trim** (Trim), **Read** (Read) and **Off** (Off). Entries in parenthesis ( ) indicate the mode as shown on the channel scribble strip. To change automation mode on a channel, select an automation mode from the soft key menu and then press the **auto** button on a channel fader. Alternatively, select a channel auto button which displays the current mode on the channel scribble strip, followed by the required mode from soft key menu. Holding down **OPTION** and then selecting an automation mode will change the automation mode on all channels.

*Refer to your DAW manual for more information on its specific automation features.*

### TRIM Mode

If your DAW supports Trim automation mode, this can be selected by pressing the **Trim** soft key in the **AuMo** (Auto Modes) menu, and then pressing a channel **auto** button. This changes the current automation mode into a 'Trim' equivalent. Holding down **OPTION** and then pressing **Trim** in the soft key menu will set Trim mode on all channels.

You can confirm that a fader is in Trim by pressing and holding the fader's **auto** button — its scribble strip will display a T in front of the normal automation mode indication. Alternatively, select the **Auto** soft key in the **StGr** (Status/Groups) menu; this will display, in the scribble strip, the automation modes of all channels.

## Automation Status Display

Pressing and holding the **auto** button on a channel fader will display the current automation mode for that channel in the channel's scribble strip. To display the automation mode for all focused channels, select the Status Group (**StGr**) soft menu, and press **Auto**.

The automation LED indications are as follows:

- No LED: Automation off
- Green LED: Read automation mode
- Red flashing LED: DAW is ready to write automation in write, touch or latch modes
- Red solid LED: Writing automation data
- Red and Green LEDs: Trim automation mode

## Suspending Automation

To suspend all automation writing and playback for the entire project/session, deselect the **SUSPEND AUTO** button. The button will flash red to indicate that the suspend function is active.

## Writing Automation (Write to Start, End or All)

In some DAW applications, you can write automation data to the start, end or whole part of a track/selection in any automation mode. To perform these functions from Duality Fuse use the following:

- CTRL + RTZ** will write automation data from the current position to the start of the track/selection
- CTRL + END** will write automation data from the current position to the end of the track/selection
- CTRL + SHIFT + (END or RTZ)** will write automation data from the start to the end of the track/selection

## Automating Cuts

As the console's **CUT** buttons have no touch sense, automation will start being written when the button is first pressed. In **Touch** mode it will return to the underlying mix pass as soon as the DAW timeline reaches the next switch change. Thus pressing and holding a **CUT** button will write data for as long as the button is held, overwriting any underlying automation. To continue to write data until you stop, select **Write** or **Latch** mode. This also applies to plug-in buttons.

## Automating Pans and Sends

As the channel V-pots have no touch sense, automation data starts being written as soon as the control is moved. In **Touch** mode the system will stop writing automation data and return to the previous level when you stop moving the control.

Your DAW may have a Touch-Timeout period which provides a time limit that allows for a certain time to continue writing automation data, after which the value of the parameter returns to the value of the underlying automation pass. Alternatively to continue to write data until you stop select **Write** or **Latch** mode.

## Automating Plug-Ins

Plug-in parameters can be automated just like other V-pots and buttons. The only difference is that some DAW applications require the controls to be armed using the on-screen menus within your DAW. Choose the automation button in the plug-in window and enable the plug-in controls to be automated.

When automating a plug-in parameter, there is no touch sense information for the V-pot or push-push switch so in **Touch** mode data will be written for as long as the control is being moved or pressed. Using **Write** or **Latch** mode for automating plug-ins will continue writing automation data until the DAW stops.

### Automation Indication for Plug-In Parameters

If a plug-in parameter is enabled for automation, the red 'LED' below the on-screen V-pot will flash. When writing automation data, the 'LED' will light continuously.

---

*Refer to your DAW manual for more information on all aspects of its automation system.*

---

---

*This page is intentionally almost blank.*

---

---

## Mackie Control (MCU) Emulation

Duality Fuse can emulate Mackie's Control MIDI protocol as an alternative to HUI protocol emulation. The software includes dedicated front panel function mapping for Logic, Nuendo, Sonar and Digital Performer.

Mackie Control Protocol originates from the Mackie Control Universal MIDI controller and its companion eight fader extender unit. The main control unit is functionally very similar to a HUI unit supporting 8 channel faders and associated controls, a master fader, transport controls and jog wheel, cursor buttons together with dedicated function key groups for workstation control. Fader resolution is 10-bit (1024 steps). The Mackie Control Unit is supplied with overlay templates for different DAW packages, which label the various function key groups specifically for each supported DAW. In addition, the default Logic grouping is supported by a number of workstations that do not have dedicated overlays. These include Live, Sequoia, Final Cut Studio and Soundtrack Pro.

### Mackie Control Emulation Advantages

- Supported by a large number of workstation manufacturers including Apple, Sony, and Steinberg.
- Plug-Ins and virtual Instruments are controlled from the channel V-pots and can be flipped onto the faders, a feature previously reserved for Pro Tools and Digidesign proprietary control surface solutions.
- Channel meters use far less MIDI bandwidth.
- 6-character labels for Track/Channel Names and parameter information.
- Master Fader control.
- Not limited to 32 physical faders — up to 48 channel faders can be assigned to DAW control

### Implementation

In Mackie Control mode, Duality Fuse emulates a Mackie Control Master Console plus multiple Mackie Extender sections. For all supported workstations, Duality Fuse should be configured, in the relevant Control Surface set up menu, as a main Mackie Control unit together with as many 8-channel extender units as required, within the limits set by Duality Fuse's fader configuration and the number of available MIDI ports (6 per layer) that support controller interfacing. For the majority of DAWs, the set up layout should follow the actual console surface layout, with the Mackie Master Console unit assigned to channels 1 – 8. Plug-ins and instruments will have their parameters assigned 'left justified' onto Duality Fuse's channel V-pots.

The majority of DAW functions are controlled via dedicated Duality Fuse front panel switches, with less reliance than the HUI protocol on the 8 x 8 soft key matrix located beneath the TFT screen. All plug-in editing is via the channel V-pots. The four encoders, together with the six switches below the centre section monitor screen, are not used.

On the channel fader strips, the **fader** button and associated status LEDs are also not implemented by the protocol. All other controls, the V-pot and associated push switch, DAW channel Solo and Cut, plus the Select and Ready functions, are all fully supported. Only mono metering information is returned from the workstation. On stereo channels, the maximum value of the left or right channel is displayed. The master fader is also included in the DAW layer when a Mackie Control template is active.

The **AUTO, PRE, IN, OUT** etc. group of centre section buttons provide different related motion control functions according to the active template.

The jog wheel, together with the **SCRUB** button, plus the cursor buttons and cursor mode switch, are active in all templates. The outer jog wheel ring is not supported, neither is the numeric keypad. However the 1 – 8 keys replicate F1 – F8 function keys in certain templates.

## Mackie Function Control Overview

As far as possible, all the function templates use button groupings and layouts that follow the original Mackie Control surface groupings, in order to simplify moving from one DAW platform to another:

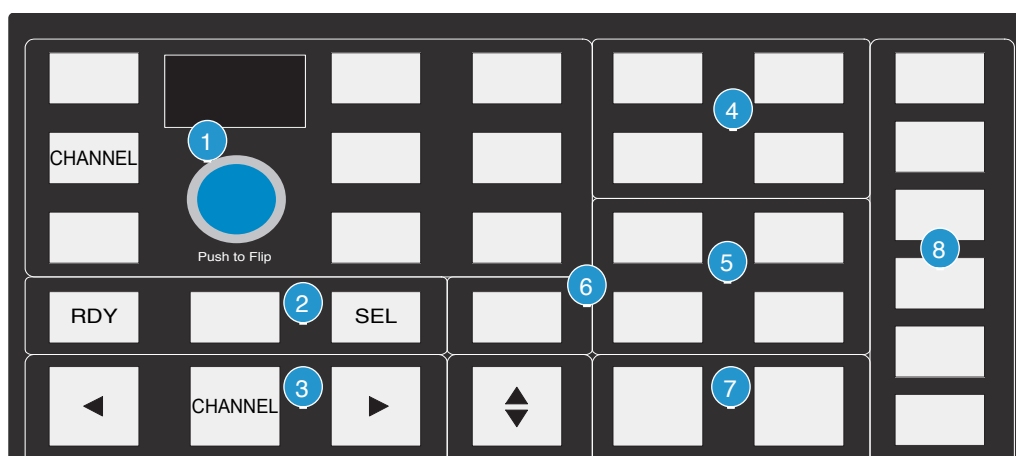

### Channel V-pot functions and display options (1)

The rotary encoder switch flips V-pot parameters onto the channel faders. The encoder itself is not used in any of the Mackie Control templates. The **CHANNEL** button has the same functions as in HUI Mode, and assigns either the console or DAW channel level control to the V-pot, according to the state of the Console Focus button.

### RDY and SEL (2)

As with the HUI protocol, the **RDY** and **SEL** buttons determine the function of the channel strip's **SEL** button. The default is the **SEL** (select) function; **RDY** accesses DAW track arming via the channel **SEL** button. The centre (blank) button is used as a discrete function in some of the templates, and corresponds to the **EDIT/GLOBAL** button located next to the **FLIP** button on a Mackie Control unit.

### Channel and control surface banking (3)

These are used in exactly the same way as in HUI Mode.

### Project/Menu buttons (4)

These offer similar functions to those in HUI mode but are template specific.

### Modifier buttons (5)

Again, these are Layout and Name template specific.

### Dedicated Functions (6), (7), (8)

These are all template specific.

## The Logic Template

Duality Fuse emulates a Mackie Control unit plus multiple Mackie XT fader expanders. Logic will accept the full 48 fader control offered by Duality Fuse. The control surface set up should be configured as shown below in the Logic Preferences/Control Surfaces menu:



### Duality Fuse's Logic Control Button Layout



When compared to the HUI protocol layout, the major changes to buttons in this section are that automation modes replace the screen display select buttons, and the inclusion of the **MARKER** and **NUDDGE** functions. **GLOBAL** uses the 8 x 8 menu matrix buttons to select different view options. **CHANNEL** is unchanged and assigns Duality Fuse's channel gain element to the V-pot. The rotary encoder switch is used to 'flip' parameters onto the faders, but the encoder itself has no function. The dot-matrix display indicates the V-pot mode with a two-character label. Plug-ins are controlled from the channel V-pots, so there is no longer an 'EDIT' select mode for the channel **SEL** button.

## Transport Control Buttons

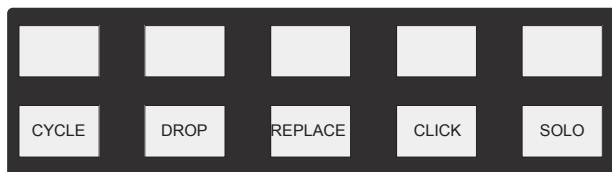

Only five of the ten transport control buttons are assigned. Full operational documentation on using Logic with Mackie Control and Extender units can be found in the Logic **Pro 9 Control Surfaces** Support (Manual) which can be downloaded from the Apple website.

## Duality Fuse's Logic Control Screen

<b>VIEW</b>	<b>Fkys</b>						<b>SSL</b>
<b>MIDI</b>	<b>IN</b>	<b>ATrk</b>	<b>Inst</b>	<b>AUX</b>	<b>BUS</b>	<b>OUT</b>	<b>USER</b>

**VIEW** is selected automatically by pressing the **GLOBAL** button; this accesses the eight global view select buttons; **VIEW** may also be selected manually if required. There are no tallies for the selected View. **VIEW** is a Duality Fuse function and not part of the MCU protocol.

Selecting **Fkys** provides access to the eight functions keys as used with the HUI interface. These are also permanently mapped to the numeric keypad, which is not supported in the Mackie Control protocol.

A 'Rude Solo' tally is displayed in the on-screen status area. This corresponds to the front panel LED on a MCU.

## Nuendo/Cubase Template

As with other templates, Duality Fuse emulates a Mackie Control Main unit plus multiple Mackie Control Extenders. MIDI control surface assignment is set up in the Remote Device list. Nuendo does not have separate profiles for the Mackie Extender, so for a 48 fader controller, six Mackie Control units are entered into the device list with the top most unit corresponding to the highest numbered eight channels on the Duality Fuse control surface, and the other units mapped to the remaining channels in descending order.

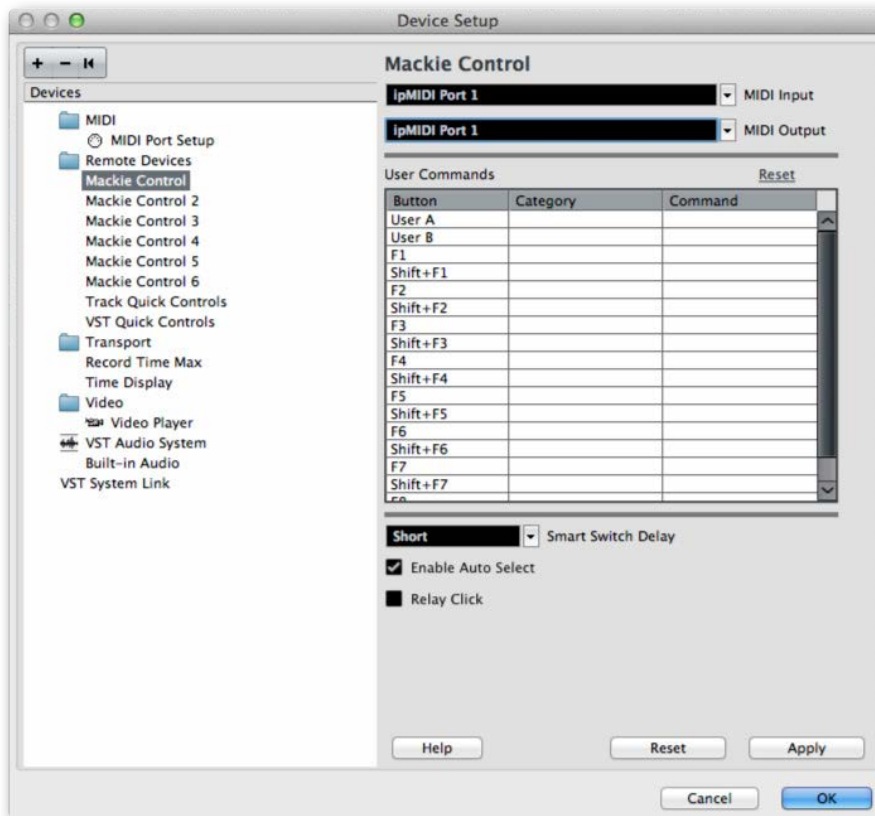

## Duality Fuse's Nuendo Control Button Layout

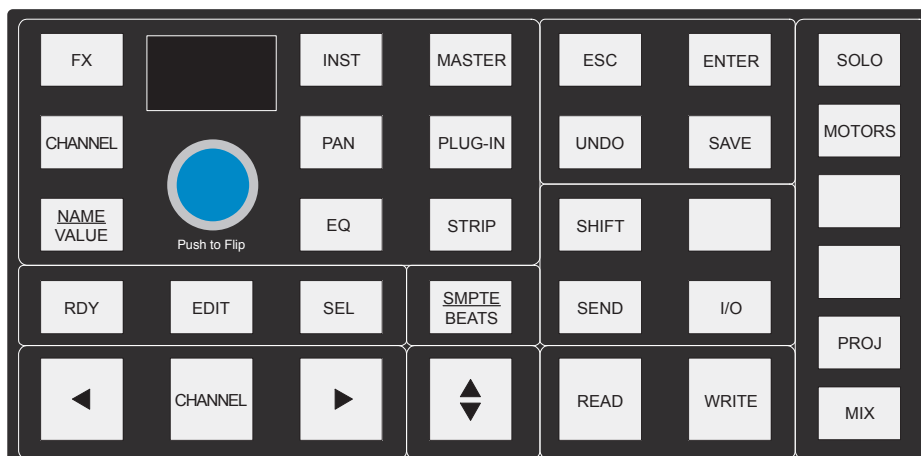

The majority of Nuendo or Cubase functions are controlled via dedicated buttons, with virtually no reliance on the 8 x 8 menu buttons located beneath the TFT screen. Full details are available in the Mackie Control manual, which is available from the Nuendo download site.

When compared to the HUI protocol front panel, the major differences here are the new control set for assigning processing parameters to the V-pots. Up and down page buttons for V-pot parameters are located within the Shift button block. The rotary encoder will also output page up/down commands when turned left or right.

**RDY** and **SEL** control the function of the channel **SEL** buttons as with the HUI interface. The **EDIT** button is used to open editing windows in Nuendo or Cubase for the current selection. Pressing **EDIT** together with **SHIFT** will close an active window.

**CHANNEL** is unchanged and assigns Duality Fuse's channel gain element or DAW channel to the V-pot according to the state of the Console Focus button. The encoder switch is used to 'flip' parameters onto the faders as before but includes all processing parameters, not just send levels.

The Transport Control buttons are assigned to related transport functions as with the HUI interface:

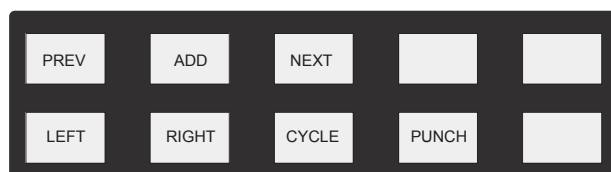

Only the **CYCLE** and **PUNCH** functions have tallies.

## Duality Fuse's Nuendo Control Screen

<b>Fkys</b>	<b>Grp</b>						<b>SSL</b>
<b>F1</b>	<b>F2</b>	<b>F3</b>	<b>F4</b>	<b>F5</b>	<b>F6</b>	<b>F7</b>	<b>F8</b>

**Fkys** provides access to the eight functions buttons. These are also mapped to the numeric keypad, which is not supported in Logic Control.

<b>Fkys</b>	<b>Grp</b>						<b>SSL</b>
<b>G1</b>	<b>G2</b>	<b>G3</b>	<b>G4</b>	<b>G5</b>	<b>G6</b>	<b>G7</b>	<b>G8</b>

**Grp** calls up the eight Fader Group buttons.

# *Duality Fuse*

**Operator's Manual**

**SECTION 4:**

**Total Recall**

*This page is intentionally almost blank.*

---

## Section Contents

<b>Section Index</b> .....	<b>.4-iii</b>
<b>Overview</b> .....	<b>.4-1</b>
<b>Total Recall and Projects</b> .....	<b>.4-1</b>
Working with Projects and Titles .....	4-2
Saving a TR Setup .....	4-3
Recalling a TR Setup .....	4-3
Deleting a TR Setup .....	4-4
Renaming TR Setups .....	4-4
<b>Total Recall Displays</b> .....	<b>.4-4</b>
<b>Resetting Controls</b> .....	<b>.4-5</b>
Automatically Reset Controls .....	4-6
Manually Reset Controls and Auto-Scan .....	4-6
<b>Copying and Swapping Settings</b> .....	<b>.4-6</b>
<b>Total Recall in the Duality Remote</b> .....	<b>.4-6</b>

*This page is intentionally almost blank.*

# Section Index

## A

AScan	4-6
Auto-scan	4-6
Automatically Reset Controls	4-6

## B

BusM	4-5
------	-----

## C

Comp	4-5
Copying TR settings	4-6
CS softkey	4-6

## D

Deleting a TR Setup	4-4
---------------------	-----

## F

fader status button	4-1
---------------------	-----

## G

GrpM	4-5
------	-----

## M

Manually Reset Controls	4-6
-------------------------	-----

## O

Offline Trim	4-5
--------------	-----

## P

Projects (TR)	4-2
---------------	-----

## R

Recalling a TR Setup	4-4
Remote browser	4-7
Renaming TR Setups	4-4
Resetting Controls	4-6

## S

Saving a TR Setup	4-3
SET ALL soft key	4-1
Soft Key Display	4-2
StRt	4-5
Swapping TR settings	4-6

## T

Total Recall Displays	4-5
-----------------------	-----

*This page is intentionally almost blank.*

# Section 4: Total Recall

## Overview

The Multi-user Total Recall (TR) package is a chargeable option for the Duality  $\delta$ elta console. If not supplied with your console, please contact your nearest SSL representative for details.

The system uses the channel meter display screens in each bay to give a graphical display of current and stored control settings for all rotary controls, faders and switches on Duality  $\delta$ elta's channel strips and centre section modules. Controls that are in different positions from the stored values are highlighted in yellow, and may be reset manually to the stored settings. Electronically latched switches such as EQ, Insert, Dynamics and Cut buttons, fader positions and the Offline Trim controls can be reset to match the stored setup by pressing the **fader** status button (the button to the left of the fader, closest to the top of the fader) twice. Pressing the **SET ALL** soft key twice will reset all the soft button functions, fader positions and the Offline Trim controls. Pressing the **SET SEL** key twice will reset the controls on all channels currently selected on the Central Routing Panel.

Selecting **AScan** (AutoScan) will scan the console for differences between the current and stored settings.

Each bay screen is used to display the settings for one channel (or the centre section), thus allowing multiple channels to be reset at the same time.

TR setups are saved within Duality  $\delta$ elta's Projects system and stored locally in Duality  $\delta$ elta's flash memory. They can be backed up as part of a console Project – see Section 6

# Total Recall and Projects

Duality  $\delta$ elta uses a logical and intuitive Project-based system within which TR Setups and Mixes (automation data) can be stored and managed. Each Project contains a number of Titles (think of these as songs, tracks, tunes etc.), and each Title contains its own set of TR Setups (and mixes).

The Projects system is accessed using the soft keys on the Master Control Panel in conjunction with displays on TFT screen above:

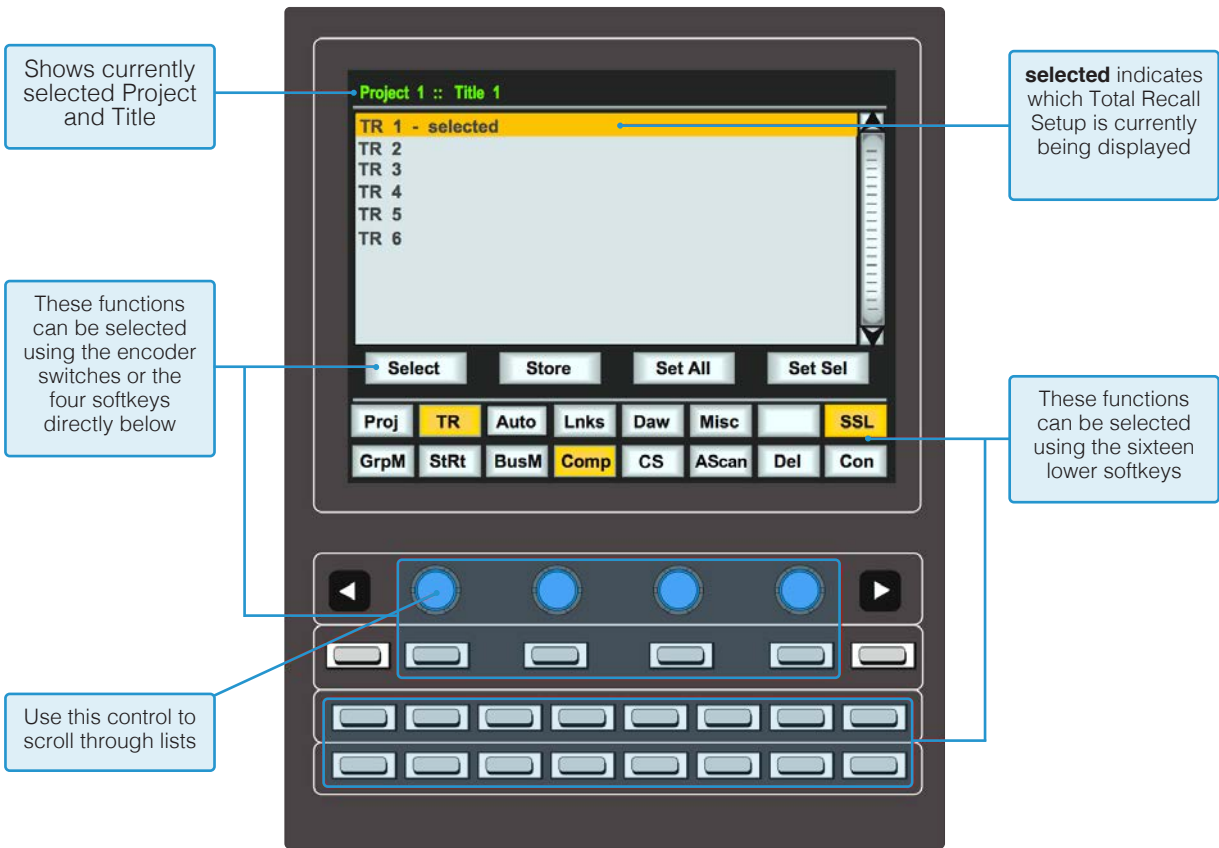

If you are not familiar with these functions (as used by the Plug-in Editor and other DAW-related functions) please refer to **Soft Key Display** in Section 3 of this manual.

## Working with Projects and Titles

At least one Project and Title must be present before you can store a TR Setup. Select **SSL** followed by **Proj**. Now select **New Proj** and the system will automatically create a new Project and Title; logically these will be named Project 1 and Title 1 (if no previous projects exist).

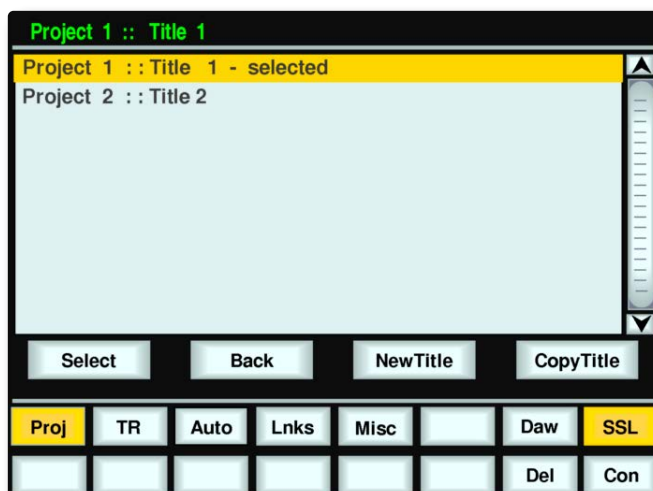

If Projects have been previously created, when you press the **Proj** key, the screen will display a list of existing Projects. Use the lefthand encoder to scroll through the list and when you find the Project you require, press the encoder switch (or soft key below the encoder) that represents the **Select** function. This makes that Project current (as indicated by the entry being highlighted in yellow, with the word **selected** after its name) and reveals the Titles in that Project. To create a new Title in a Project, select **New Title**. Titles and Projects are automatically numbered in sequence of creation. Select **Copy Title** to copy the selected Title.

Note that the top line of the display always indicates the current Project and current Title. Use the **Select** rotary control to scroll through lists of Projects, Titles, etc., and the encoder switch to select them. To return at any time to the Project list, press the soft key for **Back**.

## Saving a TR Setup

Once a new Title has been created, or a previous Title is selected, press TR followed by Store and the current console settings will be saved in the next available TR Setup. New Setups are automatically named 'TR - n' where 'n' starts at '1'. If a Setup is deleted (see below) then its number will not be re-used. The only exception to this is if all Setups are deleted; the numbering will then restart from '1'. Setups are saved to Duality  $\delta$ elta's flash memory. They can be backed up as part of a console Project – see Section 6

## Recalling a TR Setup

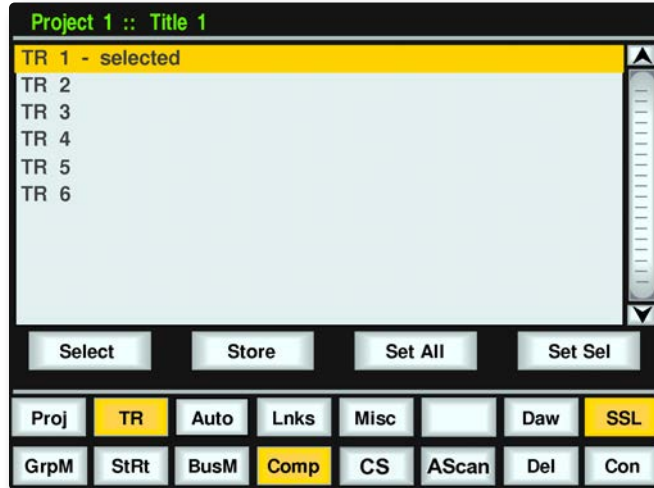

With **TR** selected, choose the required Project and Title, and scroll to the required TR Setup (see above). Press **Select** and the stored console settings will be displayed on the centre section and bay screens (see next page).

## Deleting a TR Setup

With **TR** selected, scroll and **Select** the setup to be deleted. Hold down the **Del** soft key and press the **Con** key to confirm.

## Renaming TR Setups

Autonumbered TR Setups may be named via the Duality Remote application. Please refer to Section 6 for more details.

# Total Recall Displays

As mentioned before, individual channels are displayed on the TFT screen in that same bay. To switch from one channel to another within a bay, press the **fader** status button.

In order to provide maximum clarity, the centre section display is split into four sections, all selected by soft key function is the lower row:

**GrpM** Group Control faders

**StRt** Four Stereo Return channels

**BusM** Track Bus Masters and Aux Bus Masters

**Comp** Master Compressor, Mix Reassign Matrix, Stereo Downmix, Foldback Masters, Master Fader(s)

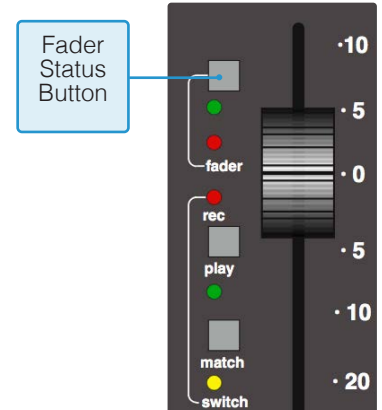

In all cases, controls that are in different positions from their stored values are highlighted in yellow:

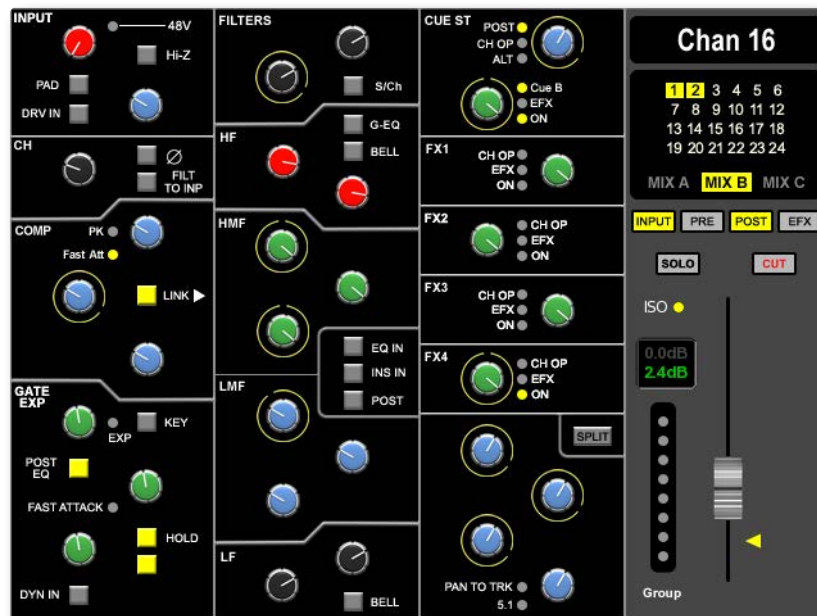

## Offline Trim

It is possible to trim the overall level of a channel fader without affecting any underlying automation data, as described in Section 5. This level is stored in the TR and is displayed in the black box to the left of the TR screen's fader: the stored Offline Trim level is displayed in the top row and the current level in the bottom. The current value turns green to indicate that it is above the stored value, and red to indicate that it is below.

To manually correct the Offline Trim, press the **OFFLINE TRIM** button in the AUTOMATION group and turn the channel V-pots.

# Resetting Controls

## Automatically Reset Controls

A double press on a **fader** status button, or on **Set Sel** or **Set All**, will reset all the non-latching switch functions, bus and processing routing and the fader position on that channel strip, channel strips selected on the central routing panel, or all channel strips respectively.

Functions automatically recalled are:

- Main (A B C) and Track Bus routing
- Filter to Input
- Dynamics Pre/Post Eq
- EQ In/Out
- Insert In/Out and Pre/ Post
- Aux/Cue On/Off and Source, Cue B and Pre/Post, plus EFX reassign
- Solo Isolate
- Fader Position
- Channel Cut
- Offline Trim

## Manually Reset Controls and Auto-Scan

All latching switches and rotary pots must be reset manually. The **AScan** (auto-scan) softkey can be used to highlight where manual resets are required – when pressed, the console scans all the channels, starting from Channel 1, until it finds a discrepancy. Correctly reset channels are indicated by their green fader status LED being lit; the first channel with any discrepancies is indicated in the centre section TFT screen, as well as by its green fader status LED flashing and its TR display appearing in its bay's TFT screen. Once the discrepancy has been corrected, auto-scan will continue scanning the remaining channels and the centre section.

## Copying and Swapping Settings

Stored TR Setups can be copied or swapped between channels. The CS softkey is used to select the Copy/Swap function between **CS** (no function), **Copy** and **Swap**. Once this button is in the appropriate state, hold down the **fader** status button on the source channel and press the **fader** status button on the destination channel. The source channel will be copied to (or swapped with) the destination channel.

---

*Note that this function does not overwrite the original Total Recall data – changes are reflected in RAM only.*

---

## Total Recall in the Duality Remote

In the Duality remote browser (See Section 6), the **Total Recall** tab allows you to rename and delete any Total Recall data from the currently selected Title.

In order to rename a setup, select the setup and press the **Rename Setup** button, or right click (or '<Ctrl> click') the setup and select '**Rename**'. Enter the name then click on **OK**.

To delete a setup, select the mix and press the **Delete Setup** button, or right click (or '<Ctrl> click') on the setup name and select '**Delete**'.

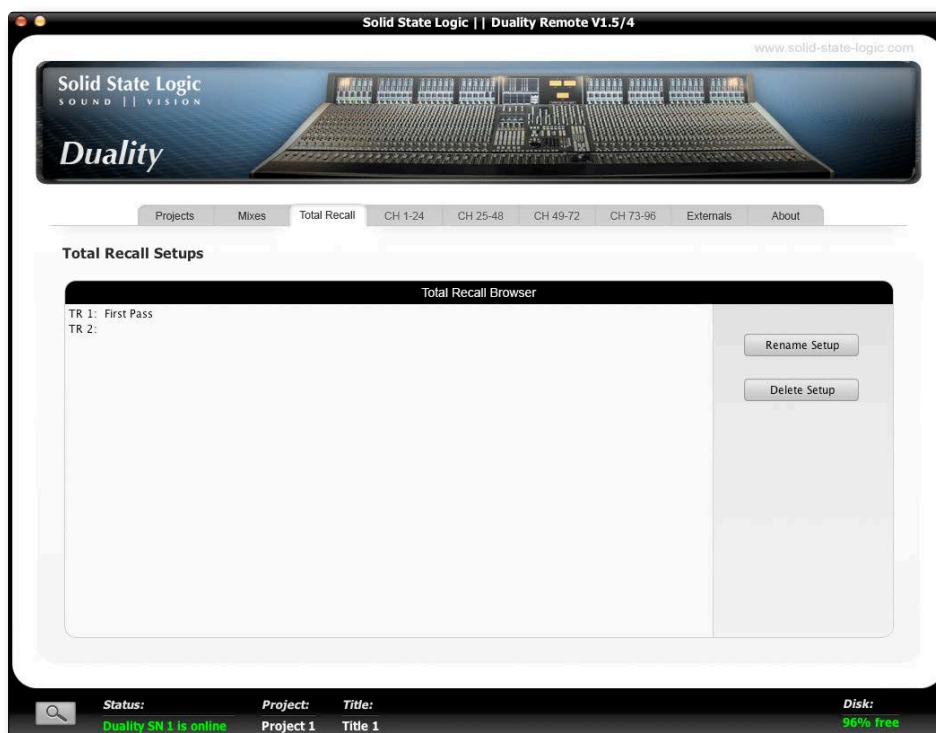

*This page is intentionally almost blank.*

# *Duality Fuse*

**Operator's Manual**

**SECTION 5:**

**AUTOMATION**

---

*This page is intentionally almost blank.*

---

# Contents

<b>δ-CONTROL AUTOMATION</b> .....	<b>5-1</b>
Overview .....	5-1
The δ-Control Advantage .....	5-1
Console Basics .....	5-2
δ-Control basics .....	5-3
The δ-Ctrl Plug-in .....	5-3
Installing the δ-Ctrl Plug-in (Macintosh) .....	5-3
Installing the δ-Ctrl Plug-in (Windows) .....	5-4
Workstation Setup – Pro Tools .....	5-5
The δ-Ctrl GUI .....	5-6
Mix Setup Workflow .....	5-7
MIXING WITH δ-Control .....	5-8
Mix Set Up .....	5-8
Writing Fader Mix data .....	5-8
Revise and Join .....	5-9
UPDATING FADER MIXDATA .....	5-9
SNAP .....	5-9
TRIM .....	5-9
Offline Trim .....	5-10
Coalescing Trim Automation .....	5-11
Fader Links .....	5-11
Switch Automation .....	5-11
MOTORS OFF .....	5-12
USING THE PRO TOOLS EDITING TOOLS .....	5-13
Write to Start, End or All .....	5-13
<b>LEGACY CONSOLE AUTOMATION</b> .....	<b>5-15</b>
Overview .....	5-15
Key features .....	5-15
AUTOMATION AND PROJECTS .....	5-16
Working with Projects and Titles .....	5-16
AUTOMATION IN THE DUALITY REMOTE .....	5-17
OPERATION .....	5-18
Activating the Automation System .....	5-18
List Mix Menu .....	5-18
Changing the Selected Mix Pass .....	5-18
Deleting Mix Passes .....	5-18
Creating A New Mix Pass .....	5-18
Mix Running .....	5-19
Mix Review .....	5-19
Dedicated Automation Buttons .....	5-20
Join and Revise .....	5-21
Discard .....	5-22
Updating a Mix Pass .....	5-22
Protection Modes .....	5-22
Summary of fader status and FSM functions: .....	5-23
Switch Automation .....	5-23
Using Match and Play to correct a switch .....	5-23

AUTOMATION OPTIONS .....	5-24
Trim .....	5-24
Trim Lok .....	5-25
Motors Off .....	5-25
Snap Mode .....	5-26
AutoTakeover .....	5-26
Offline Trim .....	5-26
Copy and Swap .....	5-27
Saving Mix Passes to your DAW Project .....	5-27
Automation Setup Options .....	5-27
<b>Notes .....</b>	<b>5-28</b>

## Section Index

### A

Automation 5-1, 5-14, 5-18

AutoTakeover 5-24

### C

Console Basics 5-2

Copy 5-25

### D

δ-Ctrl basics 5-3

δ-Control 5-1

Discard 5-20

Duality Remote 5-15

### F

Fader Links 5-9

### J

Join 5-6, 5-19

### L

List Mix 5-16

### M

Mix Running 5-17

Mix Setup 5-5

Mixing with d-ctrl 5-6

Motors Off 5-23

MOTORS OFF 5-10

### N

New Mix 5-16

### P

Pro Tools 5-11

Projects 5-14

Protection 5-20

### R

Revise 5-6, 5-19

### S

Snap 5-24

SNAP 5-7

Swap 5-25

Switch Automation 5-9, 5-21

### T

Titles 5-14

Trim 5-22

TRIM 5-7

TrimLok 5-23

### U

Updating FaderMix Data 5-7

### W

Writeto Start 5-11

Writing FaderMix data 5-6



# SECTION 5 – AUTOMATION

## δ-CONTROL AUTOMATION

### Overview

δ-Ctrl is a native AAX/RTAS/VST/VST3 plug-in that allows the user to automate their Duality console, as if it were a DAW Plug-in.

The automation engine in the DAW is used to record and playback control data from the faders and switches on the console replacing the internal time-code based automation system. The δ-Ctrl plug-in is inserted into a DAW mixer channel, which then receives and sends control data from an assigned Duality channel, VCA or Master fader via a high-speed network connection. Any associated audio on the track is unaffected and passes through the plug-in slot unprocessed.

The fader, mutes and other channel switched functions are represented as plug-in parameters and will have automation data saved in the associated plug-in track automation playlist. Desk object data together with associated automation record enable commands are streamed via the same network connection that carries ipMidi and the Logictivity Browser messages using the proprietary SSL Logictivity Network protocol. The plug-in decodes the messages and converts them to conventional plug-in parameter values, which can be saved as automation streams in the DAW track. In Automation Playback the plug-in routes the stored automation data from the DAW automation playlists back to the console via the Logictivity Network connection.

These automation playlists can be viewed and edited as normal plug-in data in the DAW tracks and will be saved alongside the rest of the session data. The plug-in's data values are expressed in dB units for faders or as text for switches, which relate directly to the parameter being controlled when automation moves are viewed in the track automation lanes for editing. The Duality fader Absolute and Trim values are saved using the same dB law as Pro Tools Fader automation so that the 'Paste Special' command can be used to copy existing Pro Tools fader data into the plug-in. *(This feature is DAW specific and may not necessarily be available with other systems.)*

### The δ-Control Advantage

- All fader moves are captured and played with the same accuracy as any other DAW automation parameter—moves are no longer quantised to Timecode frames and subframes.
- True 10-bit fader resolution.
- TCP/IP Network based control protocol – not embedded MIDI messages.
- Console Automation data automatically tracks all DAW audio editing operations.
- DAW editing tools can be used to draw and edit console fader and switch automation data.
- Console automated objects are automatically reset when a DAW project is loaded.
- All Trim moves are relative to a fixed Null point matching Pro Tools HD workflow.
- Fader Trim automation does not require the purchase of HD software or hardware.
- Automatically generated Composite Fader Automation track for merging Absolute and Trim fader data. *(Requires version 1.2 of the plug-in.)*
- Full implementation of SSL Signature Mix System features such as JOIN, REVISE, MOTORS OFF and SNAP Override from dedicated front panel switches bypassing having to use the DAW automation menu.
- MOTORS OFF mode offers the full non moving-fader SSL VCA style mix experience as preferred by key industry remixers.
- New MOTORS OFF, Touch Write mode emulates the SSL G-Series Mix system Immediate Pickup (IP) option.
- Automatic null Fader positioning when Trim mode enabled regardless of MOTORS ON/OFF mode.
- On screen display of the DAW timeline counter in the centre section δ-Control automation menu.
- Channel and Master Fader level bargraph displays on console meters and automation display screen.

In Duality Fuse the following channel parameters are automated:

- Channel levelAbsolute
- Channel levelTrim
- Channel MUTE
- EQIn/Out
- INSERT In/Out, FX 1-4On/Off
- STEREO CUEOn/Off
- The 8 VCA groups and the A B C Master faders can also be automated via the plug-in

### Console Basics

With Duality V4 software,  $\delta$ -Control is now the default automation option. The original timecode-based automation system is still included and can be re-enabled via the **Misc / Setup** menu, if required – but note that the console will require a restart. AFADA automation, although still supported, is unlikely to be used given the additional flexibility offered by  $\delta$ -Control. Existing AFADA mixes can easily be converted into  $\delta$ -Control data – see Appendix 1 for additional information.

As with the original SSL automation system, the channel fader Status keys and fader touch-sense still activate the Pro Tools Automation Write function via the plug-in, with the red and green Status LEDs indicating whether the main Volume (absolute) or Trim automation playlists are in Write mode.

When the **SSL / Auto** menu has been selected on the small screen soft keys, the actual fader levels are displayed on the channel TFT screen as continuous bars to the left of the level meters. VCA and Master faders are displayed as before on the small screen in the centre section above the soft key labels.

The small screen **Console / Auto** menu contains the user controls for the  $\delta$ -Control mix system as well as a large MIDI timecode display. This can be enabled or disabled from the **Misc / Setup** menu and receives MTC and MMC messages via ipMIDI channel 14.

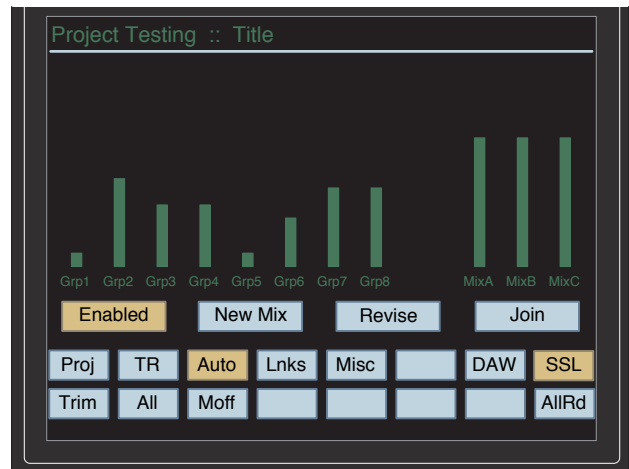

Two of the four large keys below the screen are used to enable automation and to preselect the New Mix mode. The other two large keys activate the **JOIN** and **REVISE** functions when available.

A further five keys in the lower row of the 8x8 soft key matrix select the various automation mode functions. Most of these replicate the standard SSL mix system functionality from the original timecode based system, such as SNAP, TRIM and MOTORS OFF.

As with the previous automation system, on Duality the automation mode keys are duplicated on the hardware switches above the transport controls.

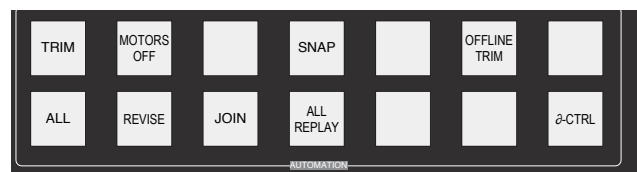

## δ-Control basics

δ-Control is optimized to work with the Pro Tools Automation **TOUCH** mode. Other update modes, such as **LATCH**, can be emulated with δ-Control without having to change the Pro Tools track automation mode. Additionally, there are equivalents to certain global HD-only automation features such as capture/punch without having to use the Pro Tools automation menus.

δ-Control also offers a Trim playlist for the console faders even with non-HD Pro Tools setups.

A plug-in channel can be 'dropped' into Write mode either from the desk fader automation status keys or by using the fader touch sensor – this is indicated by the Automation Status LED illuminating red for Absolute data and green for Trim data. (These indications are independent of the actual automation status of the track into which the plug-in has been inserted and may not reflect actual write status until the preferred Pro Tools automation mode, Touch, has been selected.)

---

*It is feasible to use the Pro Tools Write and Latch modes but desk fader status indicators will indicate only that the fader has been touched or the write status command to the plugin is active.*

---

## The δ-Ctrl Plug-in

Before mixing with δ-Control, the δ-Ctrl plug-in will need to be installed onto your workstation computer.

Download on to your workstation computer either the **SSL DELTA CONTROL.DMG** disk image (Macintosh) or the **SSL DELTA CONTROL SETUP.ZIP** file (Windows). These contain the Duality Remote and ipMIDI applications and the latest version of the installation instructions.

These files can be downloaded from SSL's website.

### Installing the δ-Ctrl Plug-in (Macintosh)

Open the disk image and mount the SSL Delta Control Plug-in.pkg; follow the installation steps as shown below.

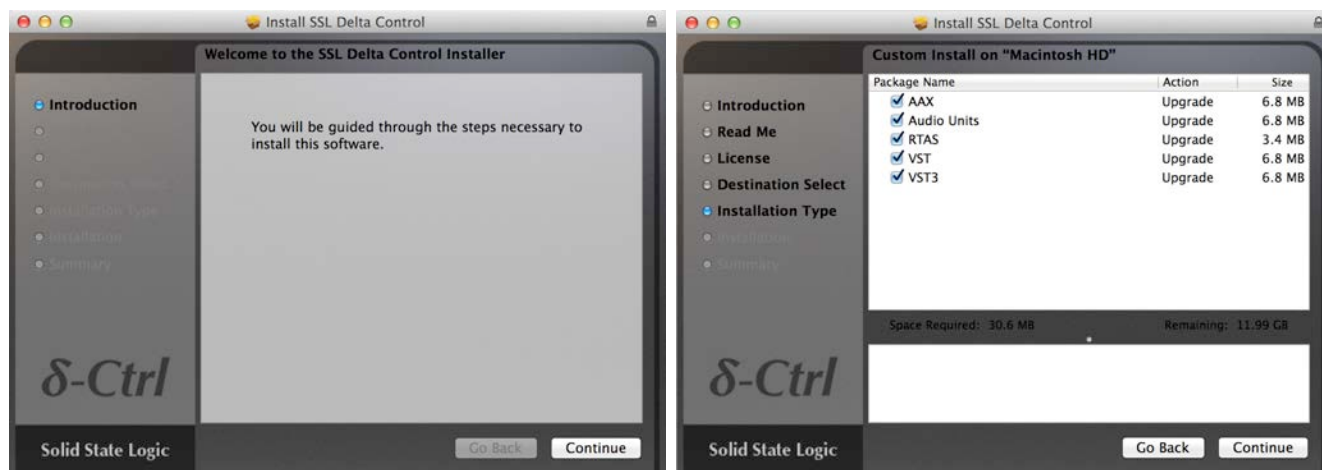

## Installing the $\delta$ -Ctrl Plug-in (Windows)

Open the zip file and run the SSL Delta Control Setup.exe file; follow the installation steps as shown below.

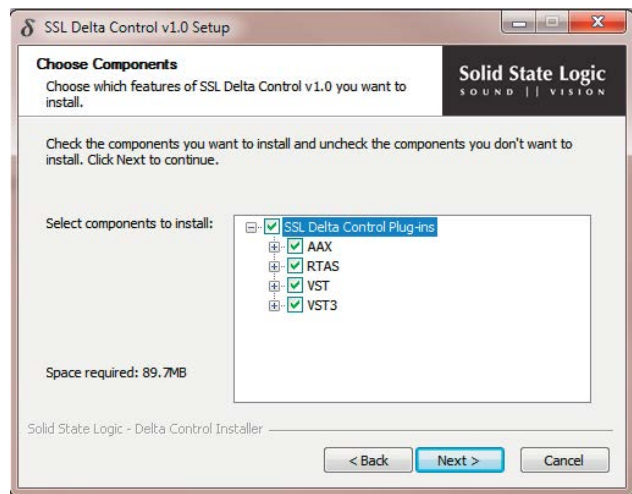

## Workstation Setup – Pro Tools

Before mixing with the plug-in the following options should be enabled in the Pro Tools **Setup / Preferences / Mixing** menu :

1. Plug-in Controls Default to **Auto-Enabled** – *Otherwise the parameters will need to be manually enabled for automation from each individual plug-in window either manually or using the Command-Option-Control-click(MAC) or Control-Alt-Start-click (PC) shortcut.*
2. Latching Behaviour for Switch Controls in “**Touch**” – *This ensures that console switch automation is recorded correctly when the track automation mode is set to Touch.*
3. Set the SSL  $\delta$ -Ctrl Plug-in as a ‘**Favourite**’ by Command-click(Mac) or Control-click(PC) the **Insert Selector** and then selecting the SSL plug-in from the **Other** category. It will then appear at the top of the Insert Selector pop-up menu for fast access.

If the desk small screen timecode display is required:

1. In the **Setup / Peripherals / Synchronization** menu set **MTC Generator port** to ipMIDI channel **14**.
2. In the **Setup / Peripherals / Machine Control** menu enable **MIDI Machine Control(Master)** and set the port to ipMIDI channel **14**.

For the MMC Locate message to update the desk timecode readout the following options should be enabled in the Pro Tools **Setup / Preferences / Synchronization** menu:

1. Machine Chases MemoryLocation.
2. Machine follows Edit Insertion/Scrub.

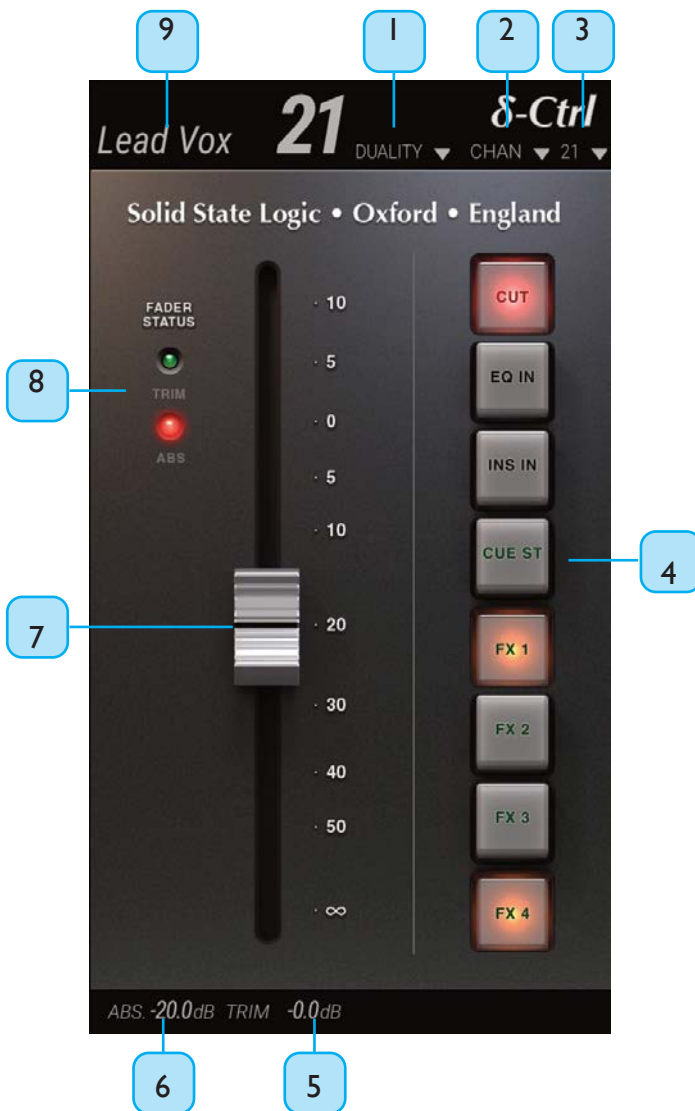
The  $\delta$ -Ctrl GUI

1. **Console Type** (Drop-down menu)
2. **Console Object** (Drop-down menu): Channel, Group or Bus
3. **Console Object Number** (Drop-down menu). Control Click to enable/disable the Auto Increment feature. *Object number is greyed out when active*
4. **Assigned Console Object Switches** – Indicates the current switch state. Click on the switch to toggle console state and to write automation
5. **Fader Level** for Trim in dB
6. **Fader Level** for ABS in dB
7. **Fader** – Click on Fader to change level. Double click to set to 0dB. Fader knob will change to gold if Trim mode has been enabled
8. **Fader Status** – Indicates status of corresponding LEDs on the console fader strips
9. **Channel label** – as displayed on the console scribble strips

The main function of the plug-in GUI is to assign the console channel object to the plug-in. Mixing with  $\delta$ -Control does not normally require use of the GUI. It is primarily for object status display.

## Mix Setup Workflow

For each console channel, VCA, or Bus master that will be automated an associated  $\delta$ -Ctrl plug-in needs to be inserted into a track in the Pro Tools session. In the case of channels, the plug-in would normally be inserted in the track feeding the channel input as this means that all console automation will follow any subsequent track edits. For VCAs and BusMasters, dedicated additional Aux tracks that contain multiple plug-ins could be used.

Insert the required number of SSL Delta Control plugins onto any tracks in your DAW session.



Open the SSL Delta Control plugin that is going to be assigned to channel 1. Set the Console Type to **Duality**, Console Object to **Chan** and Console Object Number to **1**.



Ctrl-click on the Console Object Number (1) to use the auto-increment feature - the number will now be greyed out. This feature can be disabled by a second Ctrl-click on the Console Object Number.

*Caution: Do not alt-drag (copy) Delta plugins or duplicate tracks that already have Delta plugins assigned to console channels as this will cause the Delta Control to stop working. Copying plugins and duplicating tracks with Delta plugins inserted must only be done if the plugins are not yet assigned to a channel on the console.*

As the auto-increment feature is enabled, clicking on (and opening the GUI window of) each SSL Delta Control plugin sequentially will assign each plugin to the next logical Duality channel available. Duality channel names will be pulled from the Duality console to the corresponding SSL Delta Control plugin once the console is enabled for automation.

*Please Note: It is recommended that the SSL Delta Control plug ins are added to channels with the corresponding output to Duality (for example, the Delta Control plug in that controls channel 4 of Duality added to the insert of the ProTools audio track routed to output 4 on your audio interface). This is useful for writing automation over the wave form of the audiotrack.*

To enable the console for automation, go to the SSL menu on the centre section screen, go to 'Auto', and press **Enable**.

The default state of the plug-in is: all switches off, the absolute value of the fader at  $\infty$  and the trim gain at 0 dB.

These are the initial breakpoints stored in the track automation playlists in Pro Tools. When the  $\delta$ -Control mix system is enabled channels assigned to plug-ins will be reset to the values stored in the playlists, which if no mix data has been saved, will be the default settings.

The **NEW MIX** option reverses the data flow so that the current desk settings are written to the Track playlists. The **NEW MIX** key is to the right of the **ENABLE** key and must be selected prior to using the **ENABLE** key. When the **ENABLE** key is subsequently operated the initial break points in all the active playlists will be updated to reflect the current desk settings – provided that the SNAP Mode, which is automatically turned on by the main **ENABLE** key is not deselected. At this point the **NEW MIX** mode can be deselected as the console and Pro Tools automation playlist data are now identical.

*The **ENABLE** key must be deselected before the **NEW MIX** mode can be turned off but needs to re-enabled to write subsequent automation data into the playlists.*

## MIXING WITH $\delta$ -Control

### Mix Set Up

Two approaches are envisaged, using the **NEW MIX** option a basic mix is created on the console with the mix system off and then  $\delta$ -Control automation enabled to add dynamic moves. Alternatively a mix is built up from scratch with the mix system enabled from the start. In the case of the latter approach, even with the Pro Tools tracks in Read mode, the desk settings will be saved in the Pro Tools project automatically as the initial plug-in automation playlist breakpoints are updated following any changes to the static mix. When a project is reloaded, enabling the desk automation will automatically reset the channels to the settings saved in the Pro Tools project.

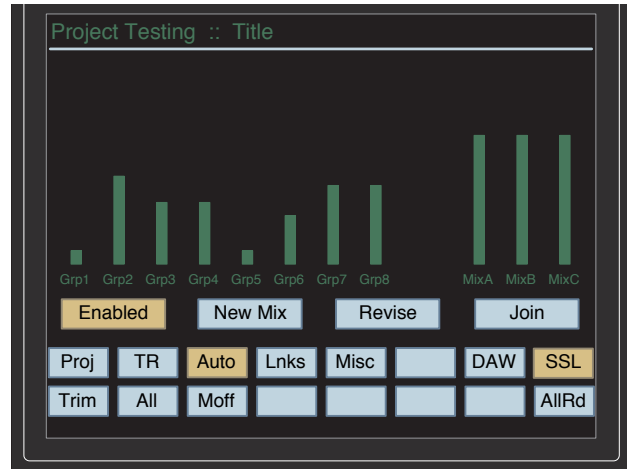

To ensure that this occurs seamlessly, when the Automation **Enable** key is operated, the SNAP Update mode is automatically selected as well so that playlists are correctly updated with the new levels when a fader is released.

---

*The SNAP update mode is described on the following page.*

---

In both cases, the  $\delta$ -Ctrl plug-ins need to be added to the Pro Tools session. It is not necessary for the Pro Tools session to be opened on a computer connected to the console, plug-ins can be added offline and will be automatically activated when the session is opened on the computer linked to the desk and the Automation ENABLE function selected. If linking the desk channel automation to existing audio tracks is not a priority, then importing track templates with the plug-in's already loaded using the Pro Tools Session Import features is another option.

### Writing Fader Mix data

Once the Touch mode has been enabled on the relevant session tracks, and with ProTools in Play, a console fader will start writing automation data either when it is touched or if the fader Status switch operated. In both cases this is indicated by the red Status LED illuminating on the fader strip and in the plug-in GUI. *(Note that in the case of the Status switch, this can be operated with Pro Tools in Stop to pre-arm the track which will drop into write on entering Play.)*

If SNAP mode is still active, then releasing a fader initiates an AutoMatch ramp to the existing playlist level. However deselecting the SNAP function means that any tracks dropped into Write via the fader will remain in Write even when the fader is released allowing a **Latch** style mode of operation without needing to change the Pro Tools track automation mode. This also follows standard SSL automation system conventions and is the key to using SSL's signature REVISE and JOIN functions to selectively return faders to Write. *(Note that with SNAP mode off, touching the fader with Pro Tools in Stop will also pre-arm the track which will drop into write on entering Play.)*

If Tracks have been enabled for Write whilst in Stop, when Play is activated and the ProTools Pre Roll function is enabled with a suitable value (one to two seconds for example), Pro Tools will start playback from the selected playback location (a marker or the last play position for example) minus the pre roll time and then drop into writing automation at the playback startpoint.

Individual Tracks can be dropped out of Write using the channel fader Status switch or globally using the dedicated **ALL REPLAY** function key or its small screen equivalent. Faders dropped out of Write will ramp back to the level stored in the automation playlist. The ramp time is the AutoMatch Time that can be found in Pro Tools **Setup/Preferences/Mixing** menu. Exiting the Pro Tools Play mode via Stop or another timeline operation will also cancel all channels currently writing automation data but without a timed ramp.

## Revise and Join

If any channels were in Write when Stop was activated, the JOIN and REVISE mode labels will be shown on the small screen larger soft-keys and the dedicated front panel keys will also illuminate. The **REVISE** key can then be used to return all the active channels in Write at the stop point back into Write and the **JOIN** key can then be used to return all the active channels in Write at the stop point back into Write but at the levels that they were at the Stop Position. REVISE is a snapshot of the fader Write status at the Stop position and JOIN is a snapshot of the fader levels and Write status at the Stop position.

REVISE and JOIN can be fired either in Play or Stop to return channels into Write or to '**punch**' the '**captured**' levels back into the mix. If REVISE and JOIN are used in Stop, then automation starts writing when Play is entered. JOIN offers a very comfortable approach to building a mix pass by allowing the engineer to refine the balance of each section in real time and then return to the start of the section and apply that balance with a single keypress.

*The REVISE and JOIN memories remain active until used. If required, they can be cleared by the use of the **ALL REPLAY** key and are automatically updated if faders are manually dropped into Write whilst Play is active.*

## UPDATING FADER MIXDATA

Once the basic mix has been established  $\delta$ -Control offers a number of hands-on tools for fine tuning the mix. These include a SNAP mode for fader updates and an additional real-time fader TRIM option.

### SNAP

Snap mode is enabled via the small screen **SNAP** soft key or via the dedicated **SNAP** key. Once active, releasing a fader drops the fader out of writing automation data and initiates a timed ramp back to the previously stored value in the automation playlist. *The ramp time is the **AutoMatch Time** that can found in Pro Tools Setup / Preferences / Mixing menu.*

The fader status key can be used to override Snap so that a fader stays writing when released even though Snap mode is On. If the associated fader status key is operated whilst holding the fader then the Snap Override mode is activated, which is indicated by the status LED flashing. When the fader is released it will stay writing at the current position until either playback is stopped or the desk ALL REPLAY function is used at which point it will 'AutoMatch' back to the original playlist value.

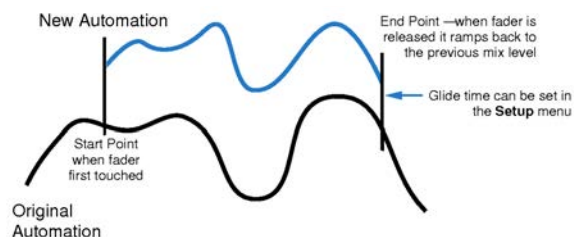

### TRIM

$\delta$ -Control supports SSL style TRIM automation for the faders without requiring Pro Tools HD software. As well as the Fader Volume automation playlist there is a separate Trim Automation playlist. Trim data is added to the Volume data and the resultant dB level is what controls the desk channel level. The Trim playlist always contains an initial break point at 0 dB (unitygain). All trim automation data is relative to the unity gain position. This follows the same convention as the Pro ToolsHD Trim feature and matches how many engineers use the Trim function with the original SSL Automation system by having a defined null position to return to.

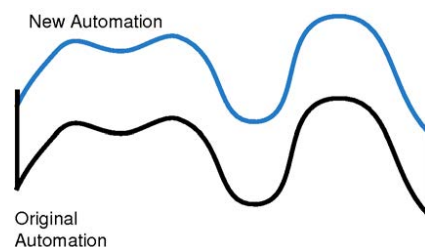

## **TRIM...** *continued*

To enable the TRIM mode for faders, activate the master **TRIM** prime function either from small screen softkeys or the dedicated function switch on Duality. Once active, the fader status keys prime the individual faders for writing Trim data, and this is indicated by the green Trim Status led flashing as well as the fader automatically being positioned at the 0 dB point (or at the current trim level if the playlist contains existing trim data). A second operation of the Status key will return the fader to controlling the channel volume and the fader will motor back to the current channel volume level. Once the required channels have been primed to write trim data the **TRIM** prime key is then deselected. The TRIM key indicator flashes whenever the master TRIM prime function is active.

The small screen **ALL** soft-key will toggle all channels into Trim if activated whilst the TRIM prime function is active. As with the other automation mode functions, Duality has a dedicated front panel ALL key. The ALL key stays lit if all the console channels have been primed for trim. Toggling one or more channels back to writing absolute volume data will turn off the ALL key tally indication. Deselecting the master TRIM prime key will also clear the ALL tally.

Any fader primed for the Trim will write trim level data when touched or if the fader Status switch is activated. This will be indicated by the green Status LED illuminating. When a fader is writing trim automation the current trim value is displayed on the desk scribble strip above the fader replacing the channel name. Unless SNAP is enabled, in which case releasing the fader drops the channel out of Write, trim data will be written until the fader is dropped out of Write by the channel Status switch or if the ALL REPLAY command is used. The current Auto Match time will ramp the trim data back to the 0 dB default if no previous trim data exists or to the previous trim value saved in the automation play list. Stopping Playback will have the same effect but without the ramp.

The Trim level is displayed on the scribble strip regardless of whether the fader is actually in Write. This allows a preset trim value to be set whilst the DAW is stopped by activating the Status switch and setting the fader to the required level. This value will be immediately written when the DAW resumes playing.

---

*Note that the Fader knob in the plug-in GUI changes to gold when **Trim** has been selected on a channel.*

---

Unlike the original Duality automation system, there is no interlock between the Volume (Absolute) and Trim automation, and Volume automation can be freely updated without affecting any existing Trim automation data. However, it is not possible (or desirable!) to write Volume and Trim automation simultaneously. If the Trim mode is selected on a Fader currently writing Volume data it is automatically dropped out of Write.

## **Offline Trim**

It is possible to trim the overall level of a channel fader without affecting the underlying automation data. To do this, press the **OFFLINE TRIM** button and use the channel V-pots to trim the channel gain. When a trim has been introduced, the **OFFLINE TRIM** button flashes and the LED below the relevant V-pots light. This level is stored and can be recalled via the console TR setup, as described in Section 4.5-9

To reset all Offline Trims to 0dB, press and hold the **OFFLINE TRIM** button. To reset individual channels to 0dB push the V-pot switch.

---

## Fader Links

Fader Links are a useful method of ganging channels without the complexity of a Master/Slave style grouping system. With a Fader Link, any fader or non-latching switch operation can be applied to all the channels in the link.

Faders retain any existing level offsets, provided no fader in the link reaches the upper or lower extremes of the fader scale. If any member of a link reaches the end of its physical travel, no member of the link can move beyond this point. To access Fader Links, press the **Lnks** soft key next to the **Autokey**.

While the **CUT** and **SOLO** switches are always included in Fader Linking along with the Fader, it is possible to exclude the remaining automated channel switches from the Link: with a fader link highlighted in the **Lnks** page, press the **ChSws** softkey. When switches are included in the Link, **switches linked** is displayed after the fader link name on the screen.

## Switch Automation

Provided that the Latching Behaviour for Switch Controls in “Touch” option has been selected in the Pro Tools **Setup / Preferences/Mixing** menu, the channel switches follow standard Pro Tools Latch Mode operation as far as automation is concerned. The initial state of the console switches are saved as the first breakpoint in the switch automation playlists. Once the Touch Mode has been enabled on a track, any changes in state of the channel switches are saved as additional breakpoints.

Editing switch automation is via the standard Pro Tools Automation editing tools.

## MOTORS OFF

Many engineers prefer not to be distracted by seeing faders moving around in front of them as they play through a mix pass. They prefer to hear the moves rather than see them.  $\delta$ -Control MOTORS OFF mode complies precisely with that requirement. Enabling MOTORS OFF disengages the motors and leaves the faders as the mix level input device with the channel high resolution digitally controlled attenuators (MDAC) as the active gain element. The channel level bargraphs in the TFT meter screen also shows the current fader playback level when the **SSL / Auto** menu is active. A mix can be built up in exactly the same way as when working on a standard VCA based SSL console. With MOTORS OFF, the fader always remains positioned at the level being written to the track when playback was stopped. Locating back to a point earlier in the mix and activating Write via the **Fader Status** switch, either in Play or whilst stopped, writes the actual fader position into the automation playlist, effectively providing a local individual fader JOIN mode. The global **JOIN** and **REVISE** keys are still active in MOTORS OFF but because the faders always retain their position when the mix pass was stopped they have the same function.

Trim automation data can also be entered in MOTORS OFF mode with the added benefit of not needing to manually position the fader at the 0dB point. When a fader is enabled for writing trim moves, the motor is temporarily engaged to automatically position the fader at 0 dB position, or at the actual trim level if the playlist already contains trim data. After that the fader can be moved manually to the required trim level which will be indicated in the channel level display above the fader and write activated via the fader status switch. As the fader always stays at the selected trim value, multiple operation of the fader status switch are equivalent to the TRIM LOK function in the original Duality automation system.

In the **SSL/Misc/Setup** menu an option is available to activate fader touch sense in Motors Off Mode. With Touch Sense Active, touching the fader will initiate the Write function, and if SNAP is also enabled, releasing the fader will initiate an 'AutoMatch' back to the data stored in the playlist but with the fader staying at its last position prior to being released. This is similar to the IP (immediate pickup) mode that was a feature of the original SSL automation system but without the need to actually move the fader to start writing automation data.

De-selecting **MOTORS OFF** repositions all the faders at their underlying channel levels regardless of the current state of the mix system.

---

## USING THE PRO TOOLS EDITING TOOLS

As the  $\delta$ -Ctrl plug-in creates standard Pro Tools automation playlists, all the Pro Tools editing tools are available for use with the saved automation. These are comprehensively described in the Pro Tools Setup Notes on page 5-31.

One of the immediate benefits of  $\delta$ -Control is that the saved Duality automation will, by default, follow all audio edits made in the workstation ensuring that all the DAW workflow editing options are available at any stage in the mix process—even though the fader automation is playing back on an external console.

A second very powerful feature is that the plug-in store its volume and trim data in the playlists using the same dB law as the Pro Tools fader volume and trim data. This means that the Pro Tools edit command “Paste Special – To Current Automation Type” can be used to copy Pro Tools fader automation into the  $\delta$ -Ctrl plug-in volume playlist to play out on the Duality channels with an accuracy better than 0.2 dB.

### Write to Start, End or All

Using the front panel HUI control keys, you can write automation data to the start, end or whole part of a track/selection for all tracks actively writing automation. These short cuts work equally well with switch states as well as fader automation.

CTRL + RTZ – will write automation data from the current position to the start of the track/selection

CTRL + END – will write automation data from the current position to the end of the track/selection

CTRL + SHIFT + (END or RTZ) – will write automation data from the start to the end of the track/selection

---

*Unused page*

---

---

## LEGACY CONSOLE AUTOMATION

### Overview

Duality Fuse's integral timecode-based automation system was developed from SSL's renowned G and K Series Ultimotion systems, designed specifically for Duality. MTC (MIDI Time Code) serves as the mix timeline reference, together with support for MMC (MIDI Machine Control) locate commands to follow non-play speed positional changes from the DAW. Mix data is saved to the internal flash memory as part of Duality  $\delta$ 's Project system, but may be backed up on your computer via the Duality  $\delta$ Browser.

---

*NOTE. With the V4 Duality software,  $\delta$ -Control is now the default automation option. Timecode based automation can be re-enabled from the **Misc / Setup** menu if required but will require a console restart.*

---

### Key features

- Frame accurate fader and switch automation data
- Moving and non moving fade rmodes
- Trim updates
- Fader links
- Cue/FX Send, EQ and Insert on/off automation
- Mix Pass history
- AutoTakeover
- Variable glide times
- Selectable Protection modes
- Match and Play switch automation updates
- Selective protection of faders and switches

The system uses the channel bay TFT screens to give a graphical display of fader levels. The centre section TFT is used to display the levels of group faders and A, B, C bus master fader levels.

## AUTOMATION AND PROJECTS

Duality  $\delta$  uses a Project-based system within which Mixes and TR Setups can be stored and managed. Each Project contains a number of Titles, and each Title contains its own set of Mixes and TR Setups. Data is stored on the inbuilt SD card and can be archived to an external computer using the Logictivity Remote, as described in Section 6.

The Projects system is accessed using the soft keys on the Master Control Panel in conjunction with displays on the TFT screen above:

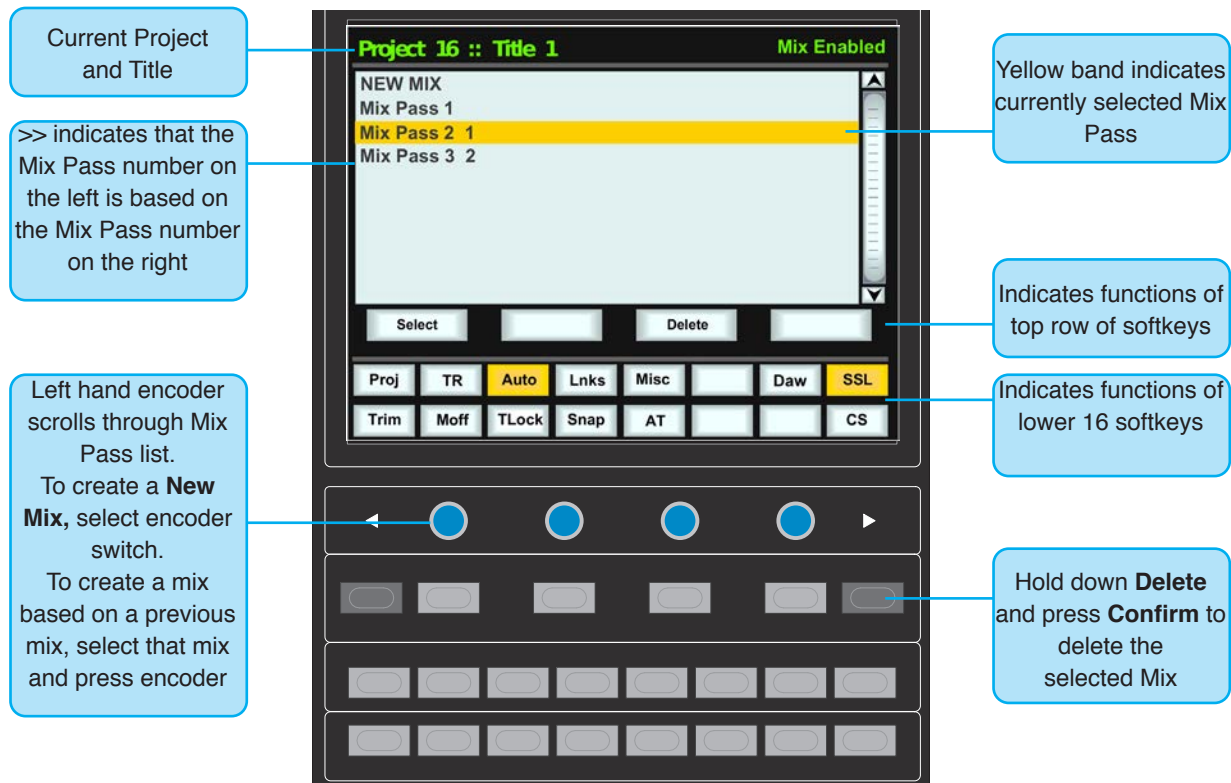

If you are not familiar with these functions (as used by the Plug-in Editor and other DAW-related functions) please refer to Soft Key Display in Section 3 of this manual.

### Working with Projects and Titles

At least one Project and Title must be present before you can store an automated Mix. Select **SSL/Proj**. Now select **New Proj** and the system will create a new Project and Title; logically these will be named Project 1 and Title 1 (if no previous projects exist).

If Projects have been previously created, when you press the **Proj** key, the screen will display a list of existing Projects. Use the left-hand encoder to scroll through the list and when you find the Project you require, press the encoder switch (or soft key below the encoder) that represents the **Select** function. This makes that Project current (as indicated by the entry being highlighted in yellow, with the word **selected** after its name) and

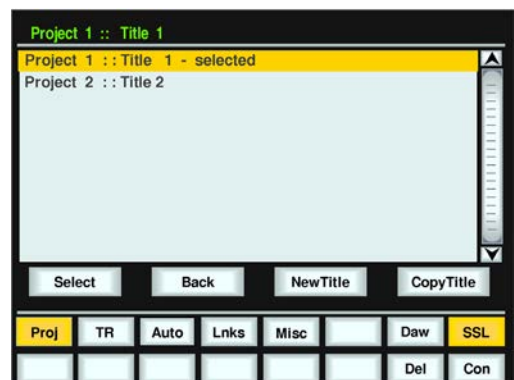

reveals the Titles in that Project. To create a new Title in a Project, select **NewTitle**. Titles and Projects are automatically numbered in sequence of creation. Select **Copy Title** to copy the selected Title.

Note that the top line of the display always indicates the current Project and current Title. Use the **Select** rotary control to scroll through lists of Projects, Titles, etc., and the encoder switch to select them. To return at any time to the Project list, press the encoder switch for **Back**.

## AUTOMATION IN THE DUALITY REMOTE

In the Duality remote browser (See Section 6), the **Projects** tab provides additional access to the Projects and Titles folders described above, and the **Mixes** tab provides additional access to the Mix list described on the following pages.

In the **Mixes** tab, it is also possible to delete and rename Mixes in this window. In order to rename a Mix, select the Mix and press the **Rename Mix** button, or right click (or '<Ctrl> click') the file and select '**Rename**'. Enter the name then click on **OK**.

To delete a Mix, select the Mix and press the **Delete Mix** button, or right click (or '<Ctrl> click') on the Mix name and select '**Delete**'.

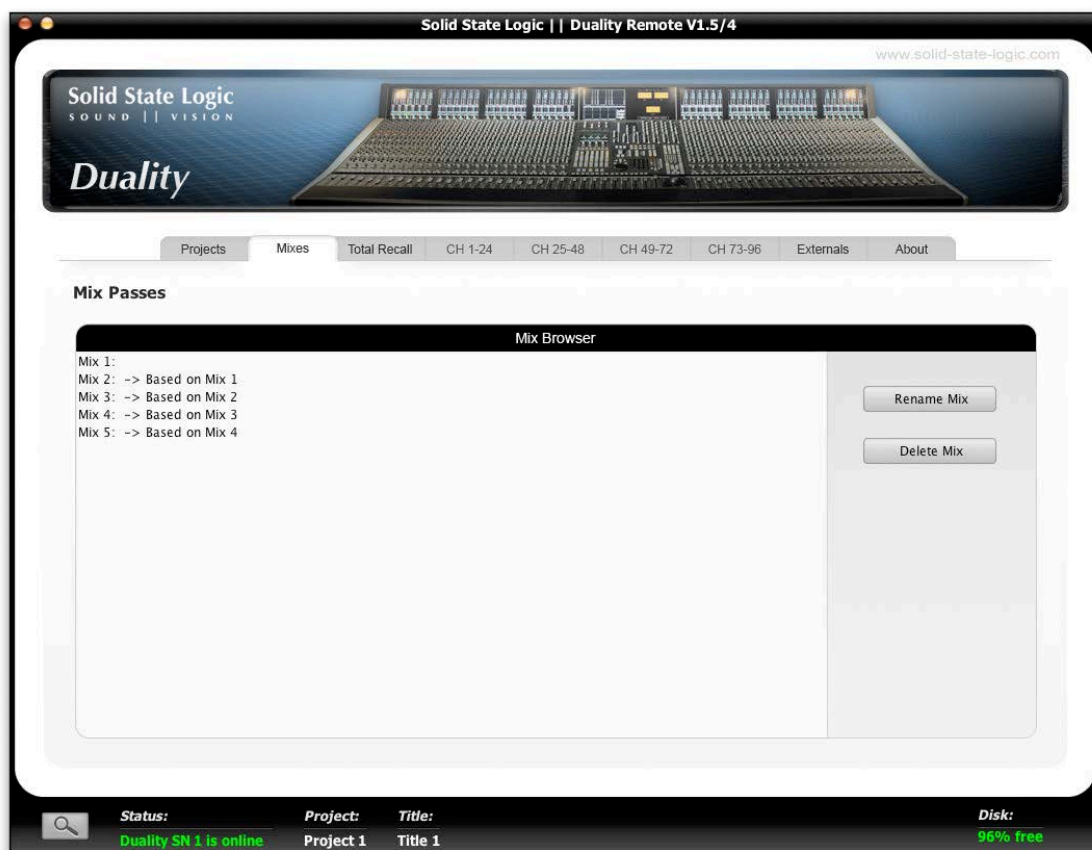

## OPERATION

### Activating the Automation System

Use the softkeys below the centre section TFT to select **SSL** then **Auto**. This calls up the main automation display with its associated soft key menu.

### List Mix Menu

The List Mix menu is the main file menu for the automation system, and shows a list of stored Mix Passes.

New Mix Passes are auto-numbered starting at '1'. If a Mix Pass is deleted (see below) then its number will not be re-used. The only exception to this is if all Mix Passes are deleted. The numbering will then restart from '1'. Mix Passes can be renamed from the Duality Remote — see Renaming Mix Passes.



### Changing the Selected Mix Pass

The left-hand encoder can be used to scroll through the list of Mix Passes. A yellow cursor band indicates which Mix Pass is currently selected for modification. The encoder's push-push switch can be used to either start a New Mix, or select a previous Mix Pass. Note that once a Mix is selected, the Mix may take a moment to load.

### Deleting Mix Passes

Mix Passes can be deleted by selecting the Mix Pass you wish to delete, holding down the **Delete** soft key and pressing the **Confirm** soft key.

### Creating A New Mix Pass

To create a new automated Mix Pass, enter the List Mix menu (shown right) and use the left-hand encoder to highlight the **New Mix** entry.

Now press the encoder switch or the **Select** soft key to select the New Mix Setup page.

All the channel faders will enter Absolute mode, as indicated by a red LED next to each fader. Depending on the **Show channel names** option selected in the **SSL/Misc/Setup** menu (see **Automation Setup Options**), the current automation status for each fader may be displayed in the scribble strip above the fader, replacing the standard 'Fader nn' label.



Select **Protect** to disconnect controls from the automation system – see below for more details.

- Automated mode:** Red LED. All automated moves are written at the current fader position.
- Manual mode:** No LEDs. The fader operates as a monitor fader only, ie. no information will be written to memory.

Pressing the **CANCEL** button (in the 'AUTOMATION' group above the 'TRANSPORT' buttons) twice quickly will return you to the List Mix page. See **Dedicated Automation Buttons** for more information.



To start a Mix, press the **Execute** key. The screen flips to show a bargraph display of fader levels for the eight centre section group master faders and the three A, B, C mix Bus Master faders. Channel fader levels are shown on the channel bay TFTdisplays.

The system saves a global 'static' reference Mix of each fader level and switch status when the **Execute** key is pressed. This is useful because it allows you to locate before the start of the Mix and recover your original levels (ie. reference Mix).

If you are writing automation in a section that had no previous mix data, when you drop out of Write the faders will return to their original levels.



## Mix Running

Press **Play** on the DAW to move forward. Check that timecode on the screen matches that of the DAW — if Duality Fuse is not reading MTC, it will not record any mixdata.

*Note that when doing the first Mix Pass, it is important to start the Pass at the beginning of the song/track.*

As soon as the automation system has locked to the MIDI timecode (MTC), the mix status display will indicate '**Mix Running**'. Simply operate the faders and switches to write your Mix as required, and the fader moves and switch data will be recorded. The DAW may be toggled freely between Stop and Play – if Fast Forward is used or the DAW is located forward, the automation data will be extended to the new position when the DAW returns to Play.

To abort the current Mix at any time, press the **Discard** soft key or the dedicated **DISCARD** button in the 'AUTOMATION' group above the 'TRANSPORT' buttons. To save the current Mix to flash memory and return to the Mix List, press the **End** soft key or the dedicated **END** button in the 'AUTOMATION' group. For more on the other buttons in this group, see **Dedicated Automation Buttons**.

## Mix Review

At any time you can rewind the system, and as soon as the DAW is located to an earlier time and valid MTC or a MMC locate position command is received, the mix system enters 'MixReview'. All faders will switch to Replay status (all LEDs are off). This operation is known as a 'rollback'.

**Mix Running:** displayed while writing new automation data

**Mix Review:** displayed when you replay previous automation data

The number after **Mix Review** (in this case **23**) indicates the number of times you have rolled back in the current Mix and added new mix data. Playing through a section without writing data does not increment the rollback counter.



When the DAW returns to Play, previously written automation data is replayed. Whilst in **Mix Review** you may rollback as many times as required to allow the Mix to be built up fader by fader. Each time a rollback takes place, and new mix data entered, the rollback counter in the mix status display increments. Faders in Write at a rollback point will automatically switch to Write when the system plays through the rollback point.

## Dedicated Automation Buttons

A group of dedicated automation buttons are provided in the centre section, just above the transport buttons:

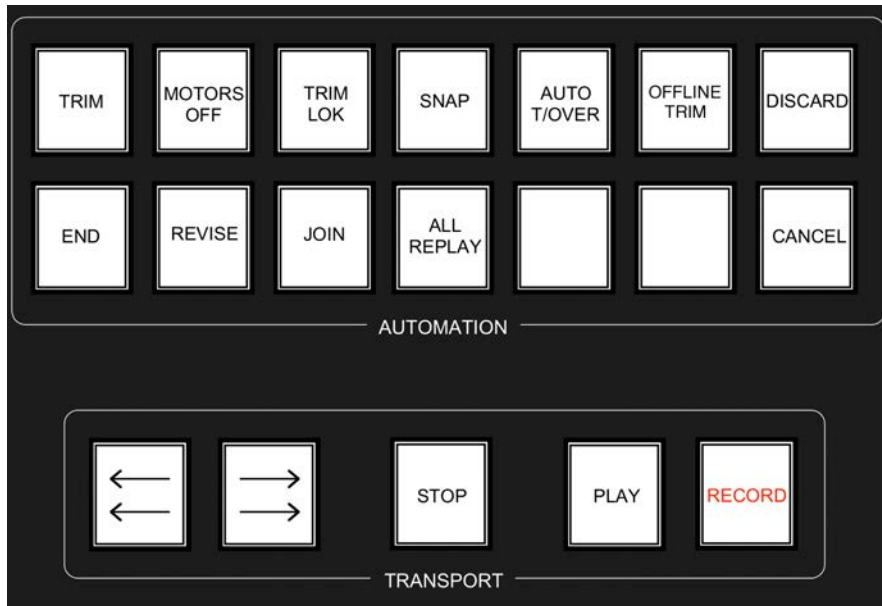

A double-press on the **CANCEL** button cancels a Mix and returns you to the Mix List page. Pressing the **END** button saves the current Mix to flash memory and also returns you to the Mix List.

Pressing the **ALL REPLAY** button simply puts all faders and switches which are in Write into Replay status, which is useful for flipping all the currently recording controls into Replay without stopping or rewinding.

The other buttons in this group are described on the following pages.

## Join and Revise

At any time during Mix Review, the **JOIN** button can be used to switch all channels that were in Write at the last rollback point, back into Write at the levels or state they were at the rollback point. This is useful, for example, when balancing levels in a chorus. Once you have achieved the right balance, simply rollback before the start of the chorus, go into Play, hit **JOIN** at the start of the chorus and the levels will drop into Write at the level set before rollback.

The **REVISE** button has a similar action except that all channels in Write at the rollback point are returned to Write at their current Mix position. This is useful when you are mixing a particular section, but have made a small mistake. Just rollback before the mistake, hit **REVISE** and channels will immediately go into Write at the current fader level, allowing you to overwrite the mistake.

Here is an exaggerated graphic representation of both functions:

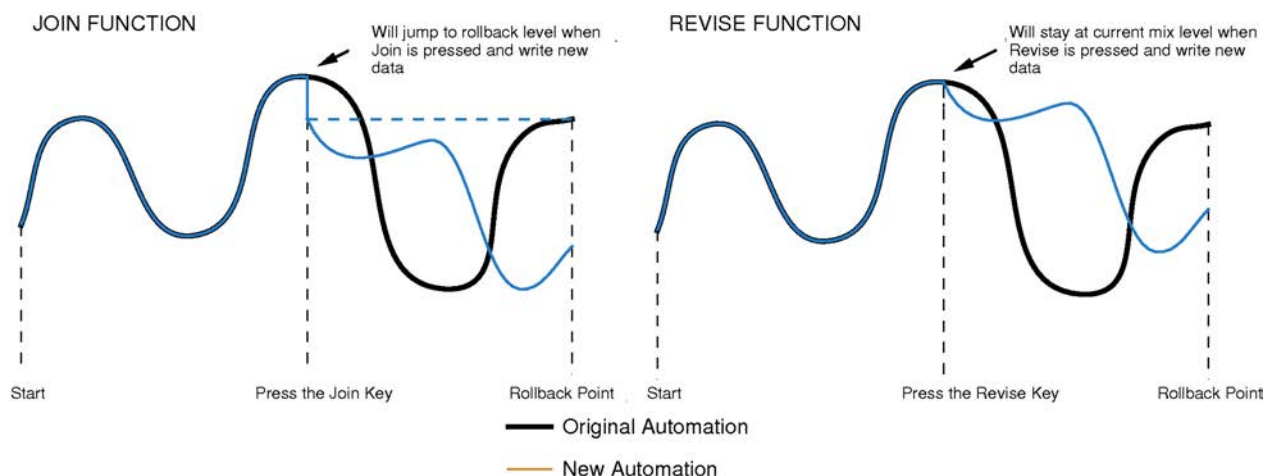

Multiple rollback memories are supported so that successive operations of **JOIN** or **REVISE** can return different sets of faders back to Write, if multiple rollbacks have taken place:

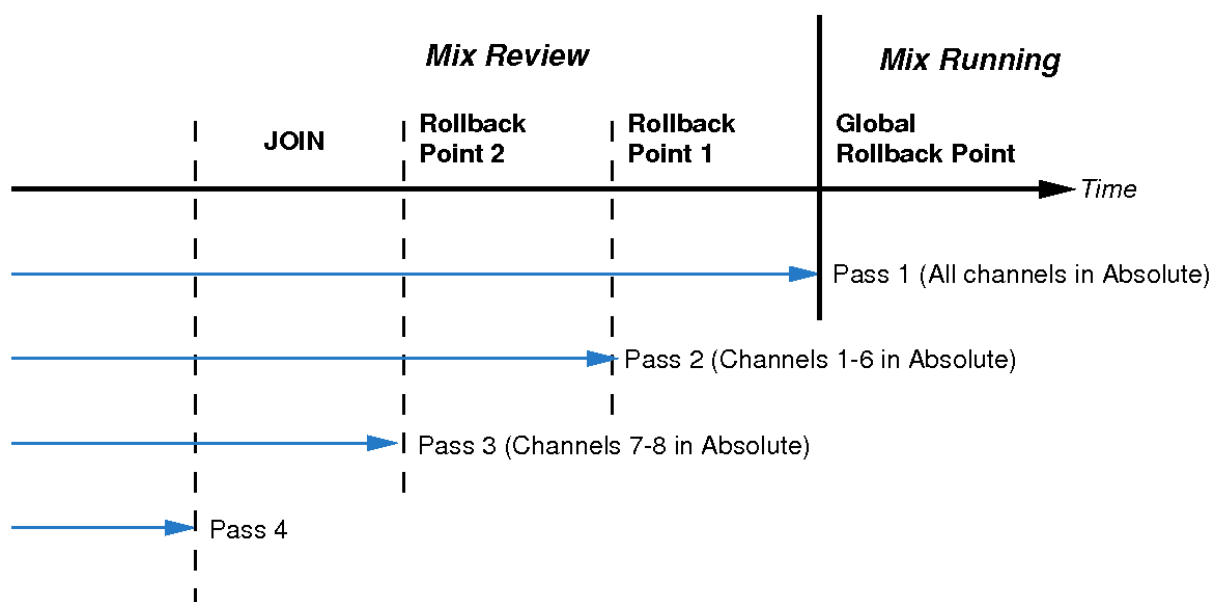

To return all faders to Absolute, use the **JOIN** or **REVISE** buttons until the 'global' rollback memory is reached, at which point all faders will return to Write either at their current position (**REVISE**), or at the levels they had at the global rollback point (**JOIN**).

## Discard

If the system is in play or stopped following a rollback operation, pressing the **Discard** soft key, or the dedicated button, clears any data recorded since the start of the rollback Pass and restores the active rollback points from the previous Pass.

## Updating a Mix Pass

To update a Mix Pass, first select the desired Mix on the List Mix page by scrolling with the left-hand rotary encoder and pressing the encoder switch.

\*\*\*Mix#\*\*\* will be displayed, and the selected Mix will now become the reference Mix.

The **FSM** (Fader Status Master) soft key will toggle all faders between Absolute and Replay or Trim and Replay.

The channel **Status** switch will toggle individual faders between Absolute and Replay or Trim and Replay.



## Protection Modes

Each component which is included in the automation can be protected globally, on a per-channel basis, or individually. This is done in the **Protection Mode** page, accessed by pressing the **Protect** softkey.

When you update a previously stored Mix, three different data protection modes become available: **Auto**, **Safe** and Manual.

- Auto** (Red fader status LED) Automation data is replayed and can be over-written, either using the fader touch sensor (motor faders on), or by pressing the **fader** status button.
- Safe** (Green fader status LED) Existing fader and switch automation data can be protected with the **Safe** option. When channels are in **Safe**, automation data is replayed but no data can be written to these channels.
- Manual** (No fader status LED) Existing automation data is protected but not played back. The fader and switches affect the audio in the normal way but movements will not be written to the automation.



*Note that in a new mix, Safe mode is **not** available.*

When the **Protect** screen is active, the lower row of softkeys become selection softkeys for the automatable switches (**Cut**, **EQ**, **Ins** (insert), **Cue** and **Fx1** to **Fx4**), and the top left softkey now displays **Set Fader** (as shown above). These nine softkeys select which controls will be affected by the **FSM** softkey and the **fader** status buttons which are used to cycle through the available Protection Modes, on a global basis (**FSM** softkey) or on a per-channel basis (the **fader** status buttons). In either case all the selected controls in the channel will be set to the displayed mode.

For example, to set all of the faders and **CUT** switches to Safe mode, activate only the **Set Fader** and **Cut** softkeys and use the **FSM** softkey to cycle the Scribble Strip to **Safe**. Alternatively, to set the 'EQIn' switch on channel 1 to Auto mode, activate only the **EQ** softkey and press Channel 1's **fader** status button to cycle the Scribble Strip to **Auto**.

When the **Protect** screen is active, all automated controls can be reset to the same mode by pressing and holding the **FSM** softkey.

To display which controls are in each mode, press the **Display** softkey – the three Protection Modes will be shown in the lower left-hand softkeys. Pressing one of these mode softkeys will cause the LEDs for all controls which are in that mode become lit. (The fader status LED now lights to indicate when the fader's current mode is selected, regardless of whether or not that mode is Auto.) Pressing any individual controls (or in the case of the fader, the **fader** status button) will cause them to be assigned to that mode, as indicated by the Scribble Strip display.

For example, if the **Manual** mode softkey is pressed, pressing a channel's FX1 on/off switch will cause that switch to be put into Manual mode, and the Scribble Strip for that channel will display **Fx1 M**.

### Summary of fader status and FSM functions:

Note that the fader status buttons and LEDs and the **FSM** softkey fill a variety of functions:

- When in Mix Enabled, a red LED indicates Write, a green LED indicates Trim (see below) and no LEDs indicates Replay. The **FSM** softkey and fader status buttons switch any faders and switches in Auto-mode between Write and Replay (or, if Trim is active, between Trim and Replay).
- When the **Protect** screen is active, a red LED indicates **Auto**, a green LED indicates **Safe** and no LED indicates **Manual** Protection mode. The **FSM** softkey and fader status buttons switch any faders and switches which have been selected in the screen between Protection modes.
- When in **Protect/Display**, a lit LED (red for **Auto** or **Manual**, green for **Safe**) indicates that the channel fader is in the Protection mode which is currently displayed. The fader status buttons can be used to add faders to the currently displayed mode.

## Switch Automation

Pressing any automatable switch (**Cut**, **EQ**, **Ins**(insert), **Cue** and **Fx1** to **Fx4**) will toggle its state and automatically start writing data (the **rec** LED by the fader will light). The switches can be returned to Replay either by rolling back or by pressing the **Play** button on the fader followed by the switch which is in Write. All channel switches can be returned with a double-press of the **Play** button.

The states of these channel switches are stored separately from the fader data. Switch data is stored regardless of the current **fader** status unless the switch has been put into **Safe** mode at the start of the Mix Pass. Whenever a channel or group function is in Write, the fader's **rec** LED will light.

Pressing the fader-based **Match** button, followed by an automatable switch, drops that switch into Write without changing the current state of the switch. **Match** and **Play** are mutually exclusive. If one is active, selecting the alternate function cancels the first one.

### Using Match and Play to correct a switch

If you have pressed a switch in the wrong place, simply move the DAW to a position before the error, put the DAW into Play, select **Match** and press the switch to automatically drop into Write without changing the stored state of the switch at that point (see diagram below for the **CUT** switch). When the switch operation has been overwritten, select **Play** and press the switch again to return to the previous automation state.

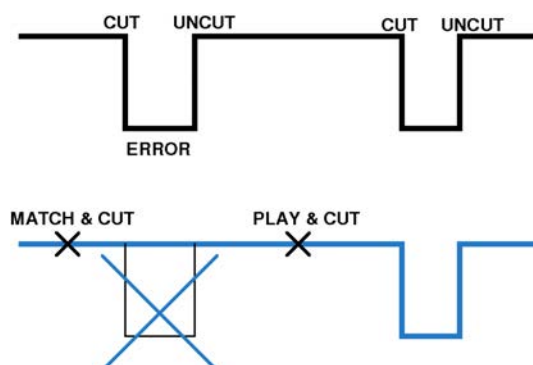

## AUTOMATION OPTIONS

### Trim

Trim status originates from VCA (non-moving fader) automation systems and uses the fader to add or subtract level from existing moves. It achieved this by setting up a 'null' fader position and then any subsequent moves trim the existing data by the amount of positive or negative change from the null point. Trim is useful, for example, when you have automated a complex vocal line that needs raising by 2dB. Rather than trying to re-write all the moves again, simply roll back, hit the **TRIM** button (in the 'AUTOMATION' group), and then move the fader up by 2dB (the fader automatically enters Trim mode when it is moved, as indicated by the green fader status LED). Locate to the end of the vocal line that needs this level increase, and press the **END** button to commit the trim to a Mix Pass.

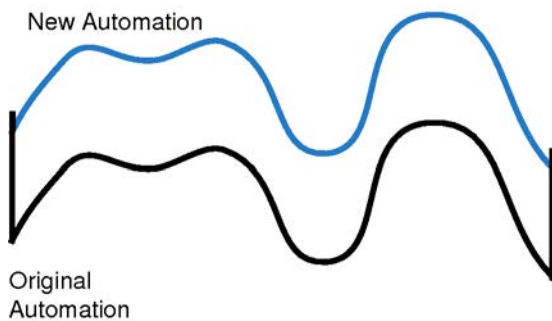

The brown (upper) line in this illustration shows the effect of the trim.

Once the **TRIM** function is selected (button is lit), faders can be put into Trim status at anytime in Mix Running or in Mix Review using the **fader** status buttons, except during the first Pass of a new Mix. Channel trim levels are shown in the electronic scribble strip, and Group/Master trim levels are shown underneath the fader levels in the Centre Section TFT screen.

If Trim is selected at the start of an Update Mix, the **FSM** soft key will toggle all faders between Replay and Trim.

Trim can be used with the fader motors on or off (see **MotorsOff**). If the motors are on, the null point will be the fader position prior to selecting the **fader** status button, or touching the fader. If the motors are off, the fader can be positioned at any suitable reference point on the scale, before entering Trim update status by pressing the **fader** status button. Duality Fuse's automation system features SSL's 'auto-nulling' feature so that each time Trim is re-enabled, a new null point is set (unless Trim Lok has been selected – see below). When writing a trimmed move, the trim value in dBs is displayed in the scribble strip above the fader.

Using the **AutoTakeover** and **Snap** functions (see below) in conjunction with a Trim update allows a seamless or smooth return to the stored mix data.

When **Join** is used with faders in Trim at the rollback point, any Trim offset will be retained and written from the point that the **JOIN** button is pressed. **Revise** returns any fader in Trim at the rollback point back to Write but with a new null point to avoid a level jump.

## Trim Lok

Trim Lok (only available in 'Motors Off' mode — see below) defeats the auto nulling feature provided for the standard Trim function, and 'locks' the null point to the position that the fader was in when Trim was first enabled in the current Mix Pass. This enables a defined trim offset to be repeatedly punched in and out throughout subsequent Mix Passes.

Select this function by pressing the **TRIM LOK** button in the 'AUTOMATION' group. When **TRIM LOK** is deselected, any stored nulled points are cleared. **AutoTakeover** (see below) can be used when Trim Lok is active. However Snap and Motors Off are mutually exclusive.

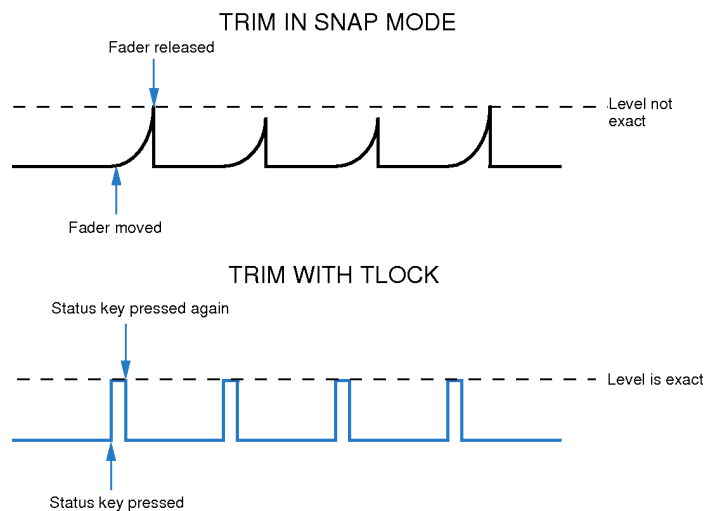

As an example of Trim Lok, how about bringing up the level of some of guitar licks in a track. If Trim is used in with Snap mode, the fader can be raised and let go repeatedly, returning to the previous level. However, it is difficult to get an identical increase in level each time, when you do this manually. If you select **TRIM LOK**, the reference value will be set, and the fader will be moved to the correct raised level. Every time you press the **fader** status button, the fader will jump to that level and, when pressed again, it will return to the reference value. Note that there will be no glide times but the maximum value will be identical each time.

## Motors Off

This mode suspends the motorised playback of mix data via the moving faders. In 'Motors Off' — select the **MOTORS OFF** button in the 'AUTOMATION' group — the faders emulate a VCA automation system. **MOTORS OFF** automatically activates the Fader Links **SuspdAll** function (see later) and can only be selected if the grouping mode is set to VCA in **SSL/Misc/Setup**.

Once **MOTORS OFF** has been enabled, the channel levels are controlled from the mix data not the position of the fader. Selecting an Absolute update writes the current physical level of the fader to mix. In Trim mode entering write does not change the stored mix level as the current fader position is used as the Trim null point. Trim with all the faders set to 0 dB via the C0dB key in the Misc Menu, is a very typical method for fine tuning a mix and is used by many engineers used to the original E Series consoles and non-Ultimation G Series consoles.

De-selecting **MOTORS OFF** repositions all the faders at their underlying channel levels regardless of the current state of the mix system. When the mix system is idle, ie. when Mix Running or Review is not displayed, touching a fader forces the channel level to match the physical fader level.

## Snap Mode

**Snap** mode uses the fader touch sensor to control both the start and end of a fader update — for fast hands-on changes to mix levels. When the fader is released, it ramps back to the previous mix level at a user-determined rate (see **Glide Frames**), then returns to Replay.

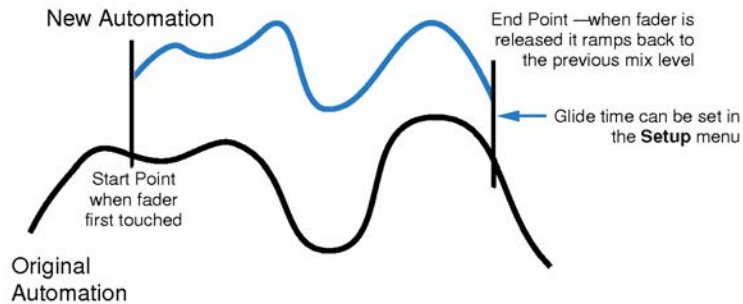

Snap mode can be overridden on any channel by pressing the **fader** button while still touching the fader knob. On releasing the fader, the channel will stay in Absolute or Trim until a subsequent **fader** button press returns the channel to Replay. This write/replay transition will include the ramped Snap glide if enabled in the setup menu (see **Glide Frames** for more detail).

## AutoTakeover

To avoid a level jump when dropping out of Write, **AutoTakeover** introduces nulling indication arrows to display the direction to move the fader to match the underlying mix level. When **AutoTakeover** has been selected, these nulling indicators can be displayed in the scribble strip for channel faders, and in the Centre Section TFT screen for Group and Master faders, by pressing the channel's **fader** status button. When the fader crosses the current mix level, it is automatically returned to Replay and disconnected from the audio gain element. The fader returns to following the mix data as soon as it is physically released.

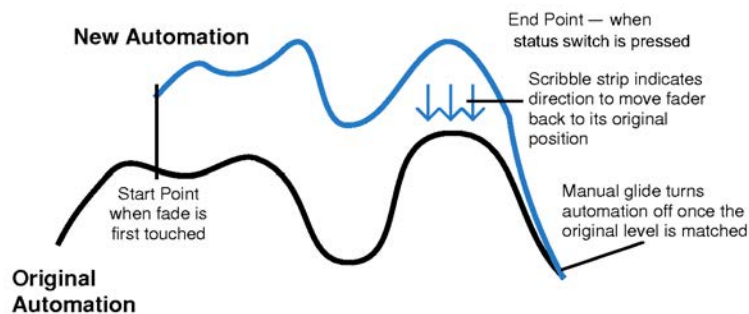

## Offline Trim

It is possible to trim the overall level of a channel fader without affecting the underlying automation data. To do this, press the **OFFLINE TRIM** button in the AUTOMATION group, and use the channel V-pots to trim the channel gain. When a trim has been introduced, the **OFFLINE TRIM** button flashes and the LED below the relevant V-pots lights. This level is stored and can be recalled via the console TR setup, as described in Section 4.

To reset all Offline Trims to 0 dB, press and hold the **OFFLINE TRIM** button. To reset individual channels to 0 dB push the V-pot switch.

## Copy and Swap

Copy and Swap (**CS** in the Auto menu) are used to interchange or transfer mix data between channels. The required function is selected by pressing the **CS** soft key to toggle between the two modes.

Copy is displayed as **Copy**, Swap as **Swap**. Select the function required, hold down the source channel **fader** button while you press the destination channel **fader** button. While the **fader** buttons are active, '**src**' and '**dest**' will be displayed in the scribble strip above each fader. Note that you can only Copy or Swap automation data when the system is in Mix Running or Mix Review.

The Copy function copies data to a single channel only. To copy the same data to multiple channels, repeat the Copy operation as many times as required.

The mix data generated by a Copy or Swap is not saved until the current Mix Pass is 'Ended'.

## Saving Mix Passes to your DAW Project

Mix Passes are stored in Duality Fuse's internal flash memory when you 'End' a Mix; each pass is saved in the Mixes folder in the current Title. They can be backed up as part of a console Project – see Section 6.

## Automation Setup Options

The following entries in the **SSL / Misc / Setup** menu are used to configure automation operations:

<b>Glide frames:</b>	Sets the ramp time in frames for the automation SNAP mode. (range 0–255)
<b>Rollback threshold frames:</b>	<p>Sets the number of consecutive, decrementing frames that the system needs to see to determine if a Rollback has taken place. The range is 0 – 10; the default is 0 frames. Increase as required if a Rollback occurs when you stop the timecode master.</p> <p>Setting the threshold to 0 means that mix data can be entered in non realtime by setting the DAW nudge value to a frame, and using the nudge forward command to step through the mix whilst moving a fader or operating switch functions. A reverse nudge command will automatically force a rollback, returning the mix pass status to Mix Review and incrementing the rollback counter.</p>
<b>In Mix show:</b>	<p>When using the automation, you have a choice of what is displayed on the consoles channel scribble strips (and below the Group and Master fader levels in the Centre Section TFT screen). The choices are:</p> <p>Automation Mode: displays the status of the faders – Auto, Safe or Manual;</p> <p>Channel names in Mix running: displays the channel names once <b>Execute</b> is pressed in automation,</p> <p>Channel names: displays the channels names regardless.</p>
<b>Mix Update Mode:</b>	Sets the default automation mode at the start of an update Mix (Replay/ Absolute / Trim).
<b>Automated switches turn off on:</b>	Select whether the off function of automatable switches is sent on the down-press or release of the button (Press / Release).

## Notes

# *Duality Fuse*

**Operator's Manual**

**SECTION 6**

**Remote Browser**

*This page is intentionally almost blank.*

# Section Contents

<b>Installing the Application</b> . . . . .	<b>6-1</b>
<b>A Note On Java</b> . . . . .	<b>6-1</b>
<b>Connecting Duality Fuse to the Computer</b> . . . . .	<b>6-2</b>
Connecting to Duality Fuse . . . . .	6-2
Project and Title Notes . . . . .	6-3
<b>Managing Projects</b> . . . . .	<b>6-4</b>
Creating a New Project . . . . .	6-4
<b>Project Options Menu</b> . . . . .	<b>6-4</b>
New Title . . . . .	6-4
Duplicate . . . . .	6-4
Rename . . . . .	6-4
Deleting a Project . . . . .	6-4
Backing Up a Project . . . . .	6-4
Restoring a Project . . . . .	6-4
<b>Managing Titles</b> . . . . .	<b>6-5</b>
Creating a Title . . . . .	6-5
<b>Title Options Menu</b> . . . . .	<b>6-5</b>
Opening a Current Title . . . . .	6-5
Duplicating and Copying a Title . . . . .	6-5
Rename . . . . .	6-6
Deleting a Title . . . . .	6-6

*This page is intentionally almost blank.*

---

## Section Index

---

### A

About Tab 6-9

### B

Backing up a Project 6-4

### C

Channel Tabs 6-7

Configuring the Remote 6-1

Connecting to the Computer 6-2

Copying project data 6-3

### D

Delete Mix 6-5

Delete Setup 6-6

DHCP 6-1

### E

Externals Tab 6-8

### I

Installing the Application 6-1

IP address 6-1

### J

Java 6-1

### M

Mixes Tab 6-5

### P

Projects Tab 6-3

### R

Rename Mix 6-5

Rename Setup 6-6

Renaming projects and titles 6-3

Restoring a Project 6-4

### S

Set fader name 6-7

### T

Time and Date 6-9

Total Recall Tab 6-6

*This page is intentionally almost blank.*

---

## Section 6 – Duality Remote

### Introduction

The Duality Fuse console allows the use of a remote browser which provides a one-stop external solution for archiving and retrieval of automation and Total Recall data along with session management functions. Users can also use this application to add Eyeconix images to their consoles TFT screens, allowing at a glance identification of track sources.

### Configuring the Duality Remote

First, download and install the Duality Remote application to the Mac or PC from which you intend to manage your Duality delta.

### Installing the Application

If you do not yet have the Duality Remote application for Duality Fuse, you can download it from the SSL website:

<https://www.solidstatelogic.com/>

The files are listed under **Duality Java Applications**. There are separate files for PC and Macintosh computers – the PC version is a .zip archive, so simply double click to unzip it; the Macintosh version is a .dmg file, which can be extracted by double clicking also.

Once successfully unpacked you should then have a stand alone Java application called '**Solid State Logic Duality**'.

### A Note On Java

The Duality Remote application is Java based and compatible with Mac OS 10.4 and above and Windows 2000, XP and above.

If you do not have Java on your computer then please visit and download it from: [www.java.com](http://www.java.com)

The Remote requires Java Runtime Environment Version 5.0, or above.

The above URL will also verify your computer's currently installed Java environment.

The console normally expects to obtain an IP Address from a DHCP server. The computer and console should therefore be connected to a network with a DHCP server. If you wish to use a fixed IP address, go to **SSL / Misc / Net** and select the **Fixed** softkey. The fixed address can be changed using the terminal diagnostic port on the rear of the console. See the following page for details.

## Connecting Duality Fuse to the Computer

Duality Fuse has an IP address. This allows any standard personal computer (Mac or PC) to connect to your console.

To do this you will need to establish a small local Network. Please refer to Section 5 of the *Duality Installation and Setup Guide* for further information.

### Connecting to Duality Fuse

If this is the first time the remote has been used, click on the  symbol – you will then be presented with pop-up displaying the available consoles’ serial numbers:

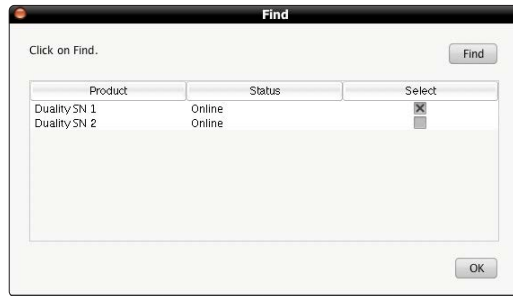

Click on the **Select** checkbox for your console and press **OK**. When you launch the Duality Remote subsequently it will automatically search and connect to the selected console. To change the console you are connected to click on the  symbol again and select a different console.

Any existing data stored on your console should now be visible in the remote. The currently selected Project and Title will be displayed at the bottom of the remote, along with the consoles serial number and the available disk space.

When Duality Remote is launched the following tabs will be visible:

- **Projects** – This shows a traditional “tree” file structure and architecture listing Projects stored on the console. On the right of the display you can also enter Project and Title information as well as session notes.
- **Mixes** – A list of Mixes associated with the currently selected Title.
- **Total Recall** – A list of Total Recall data stored for the currently selected Title.
- **Ch 1-24, 25-48 etc.** – These fields allow you to enter names for the TFT Channel displays on the console and also assign Eyeconix images.
- **Externals** – Allows you to rename the Ext A and B sources. These will appear on your console’s monitor selection.
- **About** – This contains some additional information and functions.

## Projects Tab

After launching Duality Remote the **Projects** tab will appear. All Projects are listed in the left **Projects** pane:

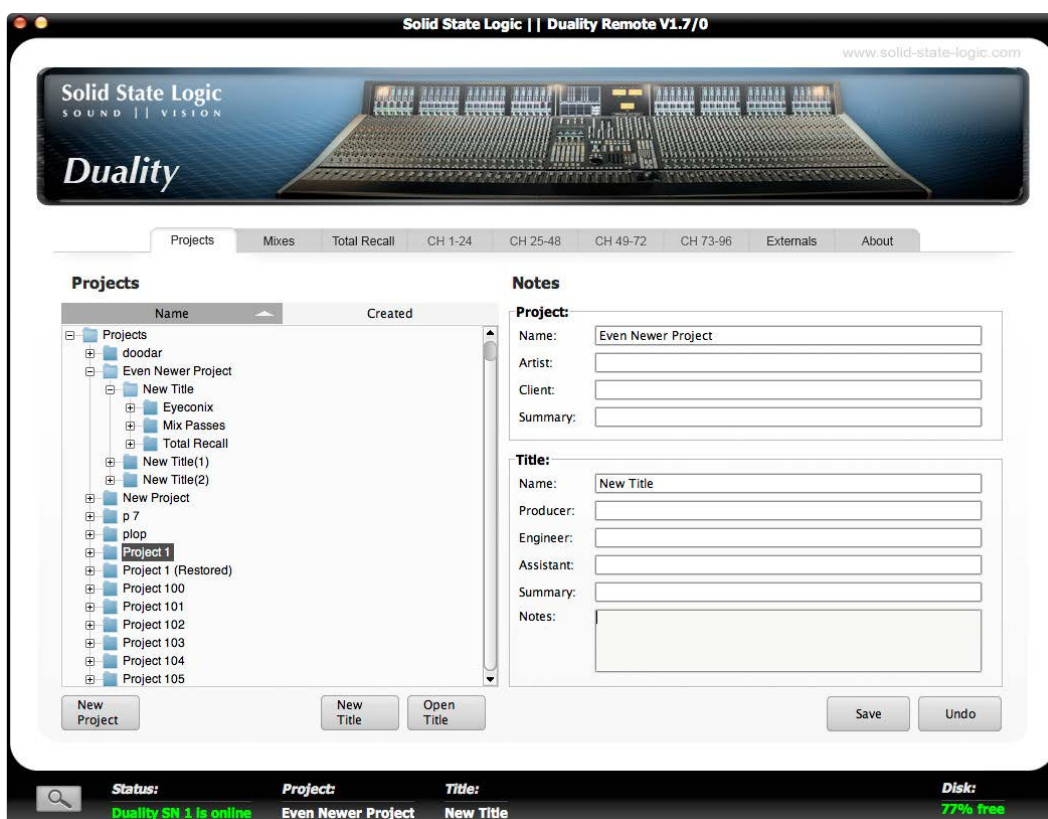

Clicking on the '+' (or '▶') sign to the left of any folder will expand the folder to show its contents. (Double-clicking on any folder name will also expand or collapse that folder). The folders are organised into sub-folders as follows:

- + The top-level **Projects** folder contains all the individual **Projects** folders
- + Each individual **Project folder** may contain any number of **Title** folders
- + Each **Title folder** will contain Eyeconix images, Mix passes and TR data folders:
  - + **Eyeconix**
  - + **Mix Passes**
  - + **Total Recall**

Note that the projects list can be viewed either by Name or by Creation date.

### Project and Title Notes

The **Notes** area on the right-hand side of the **Projects** tab allows you to record your own data related to a particular session, including personnel and any other information. The top half records information related to the Project as a whole, whereas the bottom half records information related specifically to the Title currently loaded from that Project.

Any information typed here will be automatically saved as part of the Project and Title files. Renaming Projects and Titles overwrites any names you gave them using the **Rename** button. If you leave the Project and Title name boxes blank, the Remote will create its own names. The default naming system for a Project is simply '**Project n**' where '**n**' is the lowest number not used in this way. Similarly, Titles are simply named '**Title n**' where '**n**' is the lowest unused number within that Project folder.

When you have made your changes in the **Notes** area, press **Save** to save your changes.

## Managing Projects

### Creating a New Project

To create a new Project, simply press the **New Project** button in the bottom left-hand corner of the window.

The following window will appear asking you to name the Project and the first Title within that project.

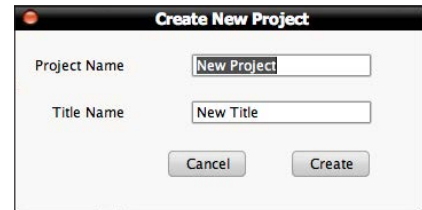

### Project Options Menu

With a project name highlighted, a right-click (or ctrl-click) will bring up the project options menu as shown:

#### New Title

This will create a new Title in the currently selected Project. Alternatively, simply press the **New Title** button beneath the Projects window.

#### Duplicate

A duplicate of the project, including any enclosed Titles, will appear beneath the Project, with a bracketed number e.g. (1) appended to the name. Subsequent duplicates will incrementally increase the bracketed number.

#### Rename

This option can be used to change the name of any Project, even if it is not the one that is currently open. Selecting **Rename** will produce the **New Name** pop-up. Type the new Project name, and click **OK**.

For the currently open Project (and Title), you can always edit the names and other details in the **Notes** area in the right hand side of the Duality Remote window. Once you have finished, press **Save** (at the bottom of the window) to save your changes.

Pressing **Undo** will cancel any changes made and revert all entries to their previous details.

### Deleting a Project

To delete a Project, select **Delete** from the options list. Click **OK** in the confirmation pop-up to delete the Project.

### Backing Up a Project

To back up a Project or export it for use in another Duality Remote, right-click (or ctrl-click) on the Project you wish to back up and select **Backup Project**. In the pop-up which appears, edit the name and destination of the file, if necessary, and press **Save**. Your Project will be exported as a ZIP file.

### Restoring a Project

To restore a Project from back-up or import a Project created in another Duality Remote, right-click on the top-level Projects folder and select Restore Project. In the pop-up which appears, locate the Project zip file you wish to restore and press Open. The restored Project will appear in the main Projects folder, with its filename appended with '(Restored)' to distinguish it from any parent Project of the same name. You can now rename the Project as described below.

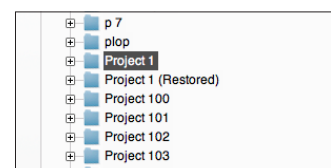
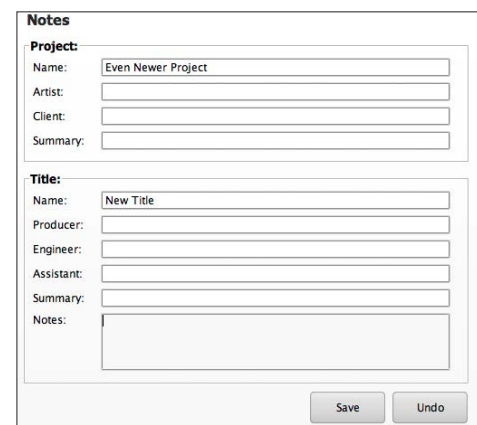
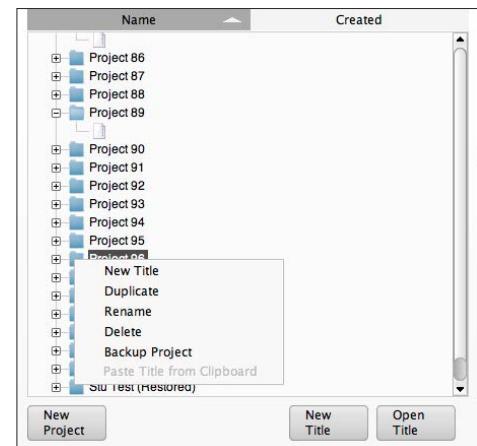

---

*Please be aware that this action cannot be undone.*

---

## Managing Titles

### Creating a Title

To create a new Title, simply press the **New Title** button and a new Title pop-up window will appear. This will create a new Title in the currently selected Project.



To create a new Title in a different Project, first open an existing Title in the desired Project using **Open Title**, then click **New Title**.

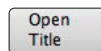

### Title Options Menu

With a Title name highlighted, a right-click (or ctrl-click) will bring up the title options menu as shown:

#### Opening a Current Title

When Duality is turned on, it will automatically open the last loaded Title. To load a different Title onto Duality (and therefore into the rest of the Remote), highlight the required Title folder and press the **Open Title** button or select **Open** from the menu list.

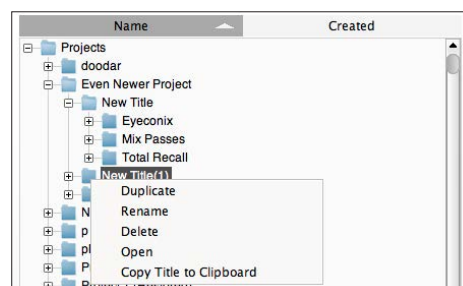

The Current Title and its Project is displayed in the **Notes** pane of the **Projects** tab – and in the top and bottom banners of the Remote window. (It is also displayed in the soft key area of the console, when the **SSL** menu set is selected without any menus active.)

Once the Title is loaded, the Duality console will assume the channel names associated with that Title. You can now also edit session notes, and recall the Title's Total Recall snapshots, as described in the rest of this chapter.

---

*Note that loading a song title into the Remote does not automatically recall a Total Recall snapshot onto the Duality control surface.*

---

### Duplicating and Copying a Title

To copy the current title, select **Duplicate**. A duplicate of the Title, including its Title Eyeconix icons, mix passes and Total Recall folders, will appear at the bottom of the same Project folder, with a bracketed number e.g. (1) appended to the Title Name indicating it is a duplicate. Subsequent duplicates will incrementally increase the bracketed number.

To copy a Title to a different Project simply drag the Title into the destination Project folder and click **OK** in the **Confirm Copy** pop-up. Alternatively, right-click (Mac: ctrl+click) on the Title folder and choose **Copy Title to Clipboard**. Right-click on the destination Project folder and choose **Paste (Title name) from clipboard**.



Title folders can be moved into other Project folders by dragging them onto the name of the Project to which you wish to move them. Press **OK** in the **Confirm Copy** pop-up which appears and a copy of the Title will appear in the new folder.

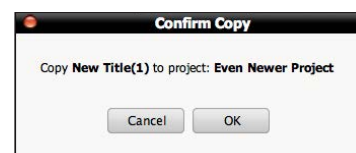

---

*Total Recall files can be dragged and dropped into the Total Recall folders of other Titles, in which case they are automatically renamed 'TR n' where 'n' is the lowest unused TR number in the Total Recall folder.*

---

### Rename

This option can be used to change the name of any Title, even if it is not the one that is currently open. Selecting **Rename** will produce the **New Name** pop-up. Type the new Title name, and click **OK**.

For the currently open Title (and Project), you can always edit the names, and other details, in the **Notes** area in the right hand side of the Duality Remote window. Once you have finished, press **Save** (at the bottom of the window) to save your changes.

Pressing **Undo** will cancel any changes made and revert all entries to to their previous details. To name a Title, select the Title which you wish to rename, and make it the Current Title. You can now edit Title name and other details in the **Notes** area in the right hand side of the window. Once you have finished, press **Save Notes** (located below the **Title** area) to save your changes.

### Deleting a Title

To delete a title, right-click (Mac: ctrl+click) on the Title folder and select **Delete** from the drop-down menu. Click **OK** in the **Confirm Delete pop-up** to delete the title.

---

*Please be aware that this action cannot be undone.*

---

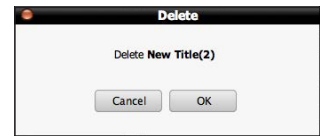

## Mixes Tab

This page shows a list of Mixes associated with the currently selected Title, as well as which mix each is based on..

It is also possible to delete and rename Mixes in this window. In order to rename a Mix, select the mix and press the **Rename Mix** button, or right click (or '<Ctrl> click') the file or folder and select '**Rename**'. Enter the name then click on **OK**.

To delete a Mix, select the mix and press the **Delete Mix** button, or right click (or '<Ctrl> click') on the Mix name and select '**Delete**'.

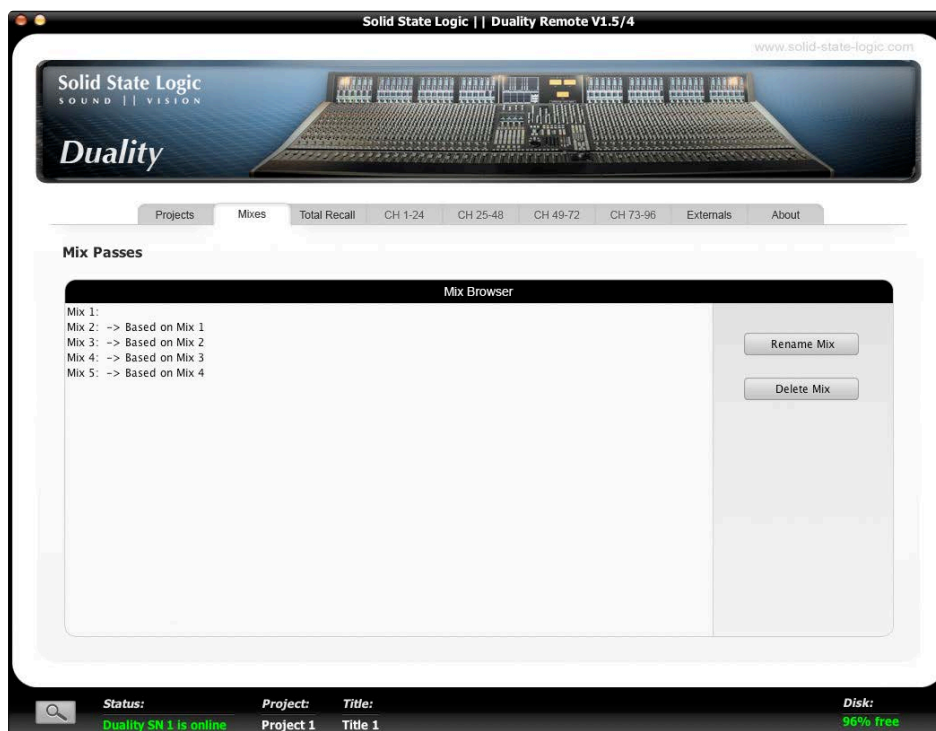

## Total Recall Tab

Here you can rename and delete any Total Recall data from the currently selected Title.

In order to rename a setup, select the setup and press the **Rename Setup** button, or right click (or '<Ctrl> click') the setup and select '**Rename**'. Enter the name then click on **OK**.

To delete a setup, select the mix and press the **Delete Setup** button, or right click (or '<Ctrl> click') on the setup name and select '**Delete**'.

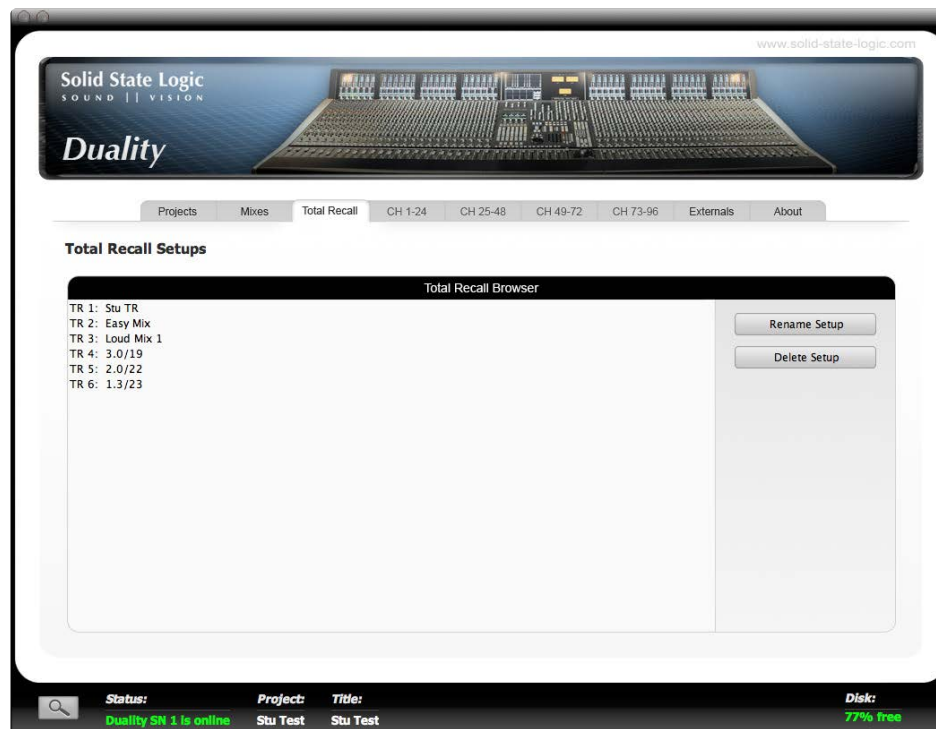

## Channel Tabs

The **CH 1–24**, **25-48**, **49-72** and **73-96** tabs allow the user to assign names and small images (eyecons) to console channels. The system is supplied with a number of standard eyecons. Others can be added by the user – see below.

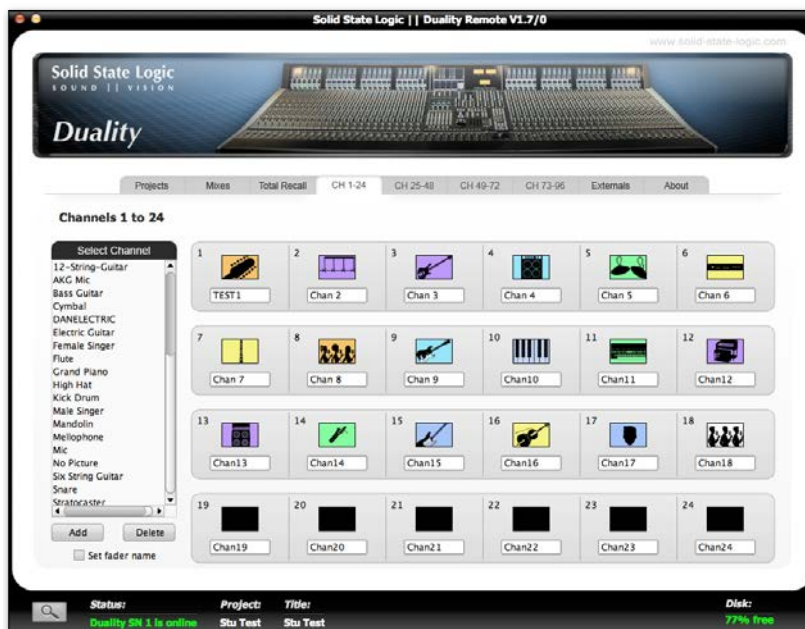

To insert a picture onto the channel's Eyeconix meter section, click on the required graphic in the left hand list and drag it to the picture rectangle above the channel name. If you want to automatically name the channel after the Eyeconix, check the **Set fader name** box beneath the Eyeconix list before dragging the graphic to the channel.

To rename a channel's TFT scribble strip display, simply click on the name (eg. 'Chan 2') and enter the required name. You can use the keyboard Tab key to move through the channel name boxes.

---

*When the Tab key is used to move to a new Name box, existing text is automatically selected ready to be over-written.*

---

To add more images to the Eyeconix list, select the **Add** button at the bottom of the left hand list and select the required graphic using the resulting pop-up. Click **Open** to add the image. Supported file formats are: gif, jpeg, tiff, and png – the Eyeconix software will automatically resize any picture brought into the remote interface.

To import all images within a folder, select the folder with a single-click and then click **Open**.

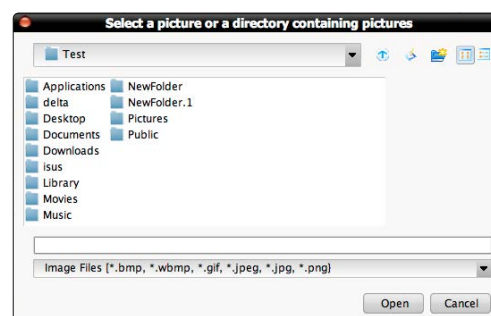

All eyecons are stored in a dedicated folder on the removable flash card in the console. A copy of the eyecons used in each Title is stored in the Eyeconix folder inside the Title folder. This ensures that Project archives will automatically include all the eyecons used in that Project.

To delete a graphic from the list, highlight it and select **Delete**. Note that if you delete one of the system eyecons it will be restored next time you restart your Duality  $\delta$ elta.

---

*Note that systems fitted with LCD scribble strips support a maximum of six characters. Longer names will be intelligently shortened to this length.*

---

# Externals Tab

This page allows you to rename the Ext A and B sources which will appear on your consoles monitor selection. Up to 4 characters are allowed for each of the four external sources A and B.

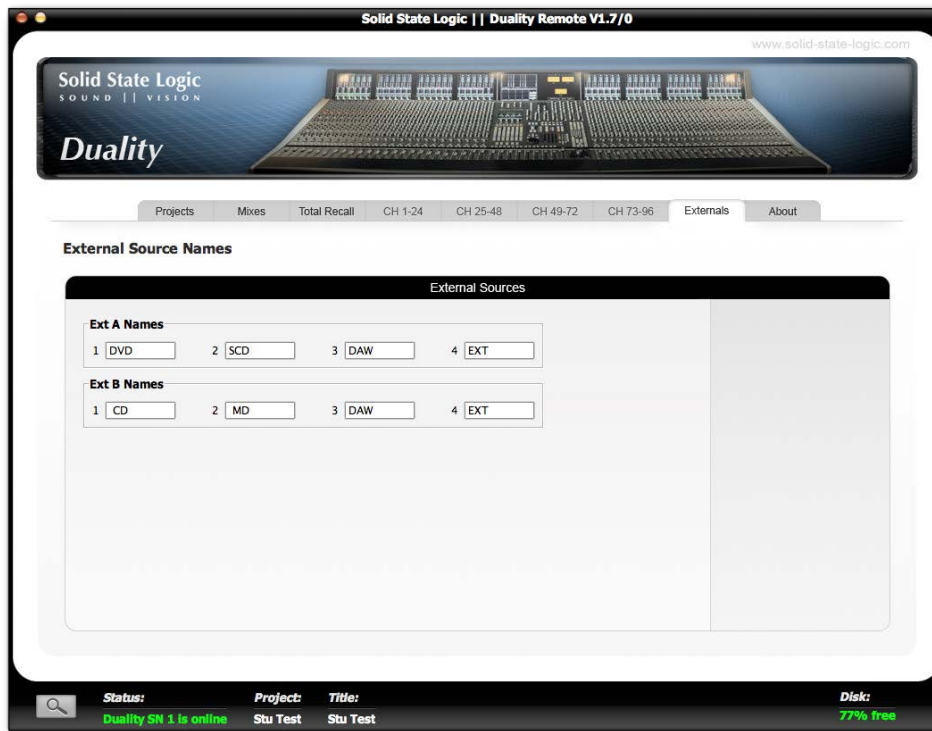

## About Tab

The About tab shows the software versions of both the Duality  $\delta$  console and the Duality Remote software and allows the desk clock to be set, and provides links to important pages within the SSL website.

Clicking on the box underneath the **Time and Date** legend will sync the Duality  $\delta$  to the time and date on your computer, in order for mixes and total recall setups to be time and date stamped (these are not currently displayed).

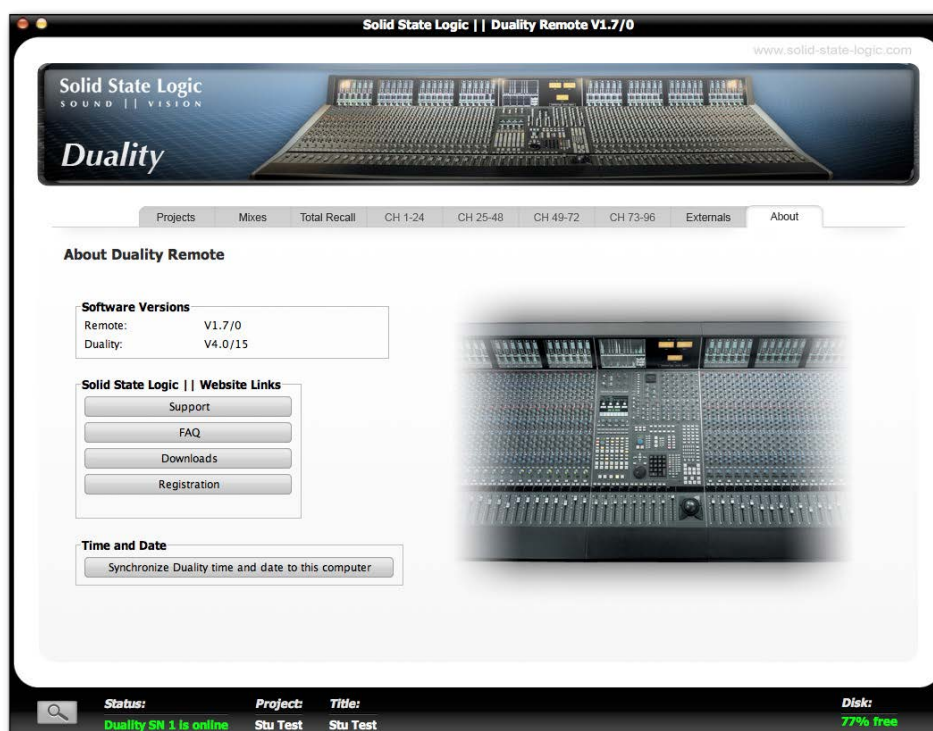

---

*This page is intentionally almost blank.*

---

# *Duality Fuse*

**Operator's Manual**

**SECTION 7:**

**Fusion Processing**

---

*This page is intentionally almost blank.*

---

## Contents

<b>Fusion processing</b> .....	<b>7-1</b>
Introduction .....	7-1
<b>Processing Section Overview</b> .....	<b>7-3</b>
<b>Signal Flow Overview</b> .....	<b>7-4</b>
<b>Processing In Detail</b> .....	<b>7-5</b>
O/LOAD (Overload) .....	7-5
Input Trim .....	7-5
HPF (High-Pass Filter) .....	7-5
The 6 Colour Circuits .....	7-6
Vintage Drive .....	7-6
Violet EQ .....	7-8
HF Compressor (High Frequency Compressor) and Stereo LMC (Listen Mic Compressor) .....	7-9
HF Compressor .....	7-9
Stereo LMC (Listen Mic Compressor) .....	7-9
Stereo Image .....	7-9
Transformer .....	7-10
Stereo Insert .....	7-11
Insert (Standard Mode) .....	7-11
Insert (M/S Mode) .....	7-11
Bypass Modes .....	7-11
Bypass (Standard Mode) .....	7-11
Bypass (Post I/P Trim) .....	7-11
Output Trim .....	7-11
Master Meter .....	7-12
Front Panel Switch Haptic Feedback (Button Clicks!) .....	7-12
Precision Image Adjust .....	7-12
Fusion Routing Switch .....	7-12
User Switches .....	7-12
User Switch Mode Programming .....	7-12
<b>Fusion Signal Routing</b> .....	<b>7-13</b>
Patchbay and Signal Routing .....	7-13
Fusion and Mix Bus Inserts .....	7-14
Fusion Signal Flow Examples .....	7-15
Fusion processing routed to MIX A with Bus Compressor AFTER Fusion Processing .....	7-15
Fusion processing routed to MIX A with Bus Compressor BEFORE Fusion Processing .....	7-15
Fusion processing routed to STEREO SUBMIX .....	7-15
Fusion processing - Independant routing .....	7-16
Fusion processing - Independant routing, patching into Mix B (or Mix C) .....	7-16
<b>Settings Mode &amp; Factory Reset</b> .....	<b>7-17</b>
Entering Settings Mode .....	7-17
Meter & Switch Brightness .....	7-17
Relay Feedback .....	7-17
Exiting Settings Mode .....	7-17
Factory Reset .....	7-18
Simon Says Game .....	7-18
<b>Fusion Section - Other Settings</b> .....	<b>7-19</b>
UID Display Mode .....	7-19
Unique ID (UID) .....	7-19
Hardware Revision .....	7-19
Soak Mode .....	7-19
<b>Fusion - Block Diagram</b> .....	<b>7-20</b>
<b>Fusion - Recall Sheet</b> .....	<b>7-21</b>

---

*This page is intentionally almost blank.*

---

# Section 7 - Fusion Processing

## Introduction

The Fusion processing collection started out as a rack unit designed to provide a set of new analogue processing tools to enhance the mix bus for any audio mixing process.

The critical path in any mix leads to the master mix bus, where all the individual instruments are bound together. In today's hybrid studio, the prevalence and importance of mix bus processing is ever-present. The DAW's mix bus inserts slots are often stacked high with plug-ins seeking to inject various aspects of analogue mojo or magic. However, even after all insert slots are filled, that authentic analogue edge is still lacking and can often prove difficult to achieve convincingly when mixing inside the box alone. Engineers often look towards multiple pieces of real analogue outboard equipment instead and this was the seed from which Fusion as an idea began to grow.

We started the journey through months of research - subjectively listening to and objectively measuring a vast array of analogue equipment, to pinpoint all of the most desirable analogue characteristics and behaviours. This "hit list" of differing sonic flavours, difficult to achieve with digital emulations alone, formed the base from which Fusion's five (now six\*\*) analogue colour circuits would be engineered.

"The Analogue Hit List"

- ▶ #1 - A rich analogue EQ with gentle shelving filters.
- ▶ #2 - Smooth top-end rounding, in the analogue domain.
- ▶ #3 - Additional harmonics and gradual saturation that emerge from an analogue 'sweet spot'.
- ▶ #4 - Wider stereo imaging with more depth via true Mid/Side processing.
- ▶ #5 - Transformer mojo.

The first circuit to emerge as a result of the work was the **VIOLET EQ**, a new SSL shelving EQ with a refined  $\pm 9$ dB gain range. Next came the **HF COMPRESSOR** circuit as a tool to tame unwanted top-end brittleness and restore a natural analogue roll-off. Then came the **VINTAGE DRIVE** circuit, our new non-linear saturation circuit that was tweaked over several months to hone its unique character. The **STEREO IMAGE** circuit followed as a way of providing the often much-missed analogue mid-side processing. The custom-designed **TRANSFORMER** circuit completed the final piece of the puzzle and again involved many rounds of fine-tuning to settle on the design. But we didn't just design Fusion in the isolation of SSL HQ; when the first prototypes were complete we sent them off to a selection of trusted engineers and made further adjustments to the circuits based on their feedback.

---

*\*\*During the development of **FUSION** there were many trials and experiments with the five analogue circuits. One variant of particular interest was an alternative mode for the **HF COMPRESSOR** section, making it operate across the full audio spectrum. This work was done late in the development cycle and with little time to validate before the units public release, hence it was held back from release and left as an 'easter egg' in the unit, with a plan to announce if validation went well and if the circuit variance was thought useful. As the design of the **HF COMPRESSOR** section was based on the legendary SSL Listen Mic Compressor circuit, it came as no surprise that this alternative mode would definitely be useful, and hence we publicly announced (a little later than originally anticipated) how to access this 'new' processing feature.*

---

---

*Blank page*

---

# Processing Section Overview

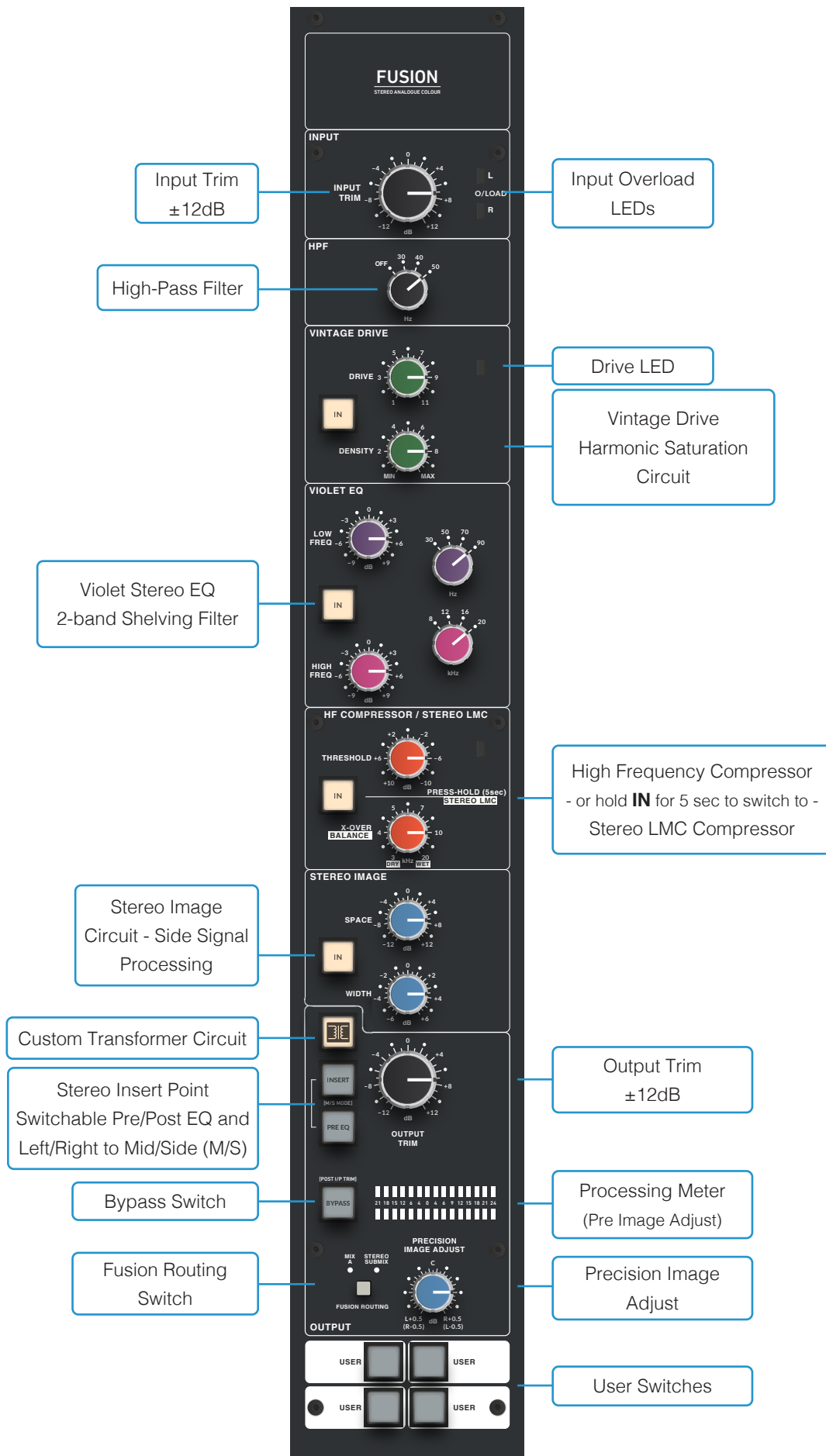

## Signal Flow Overview

A detailed Block Diagram is available in the Appendices. The diagram below gives you an overview of the signal path options Fusion provides.

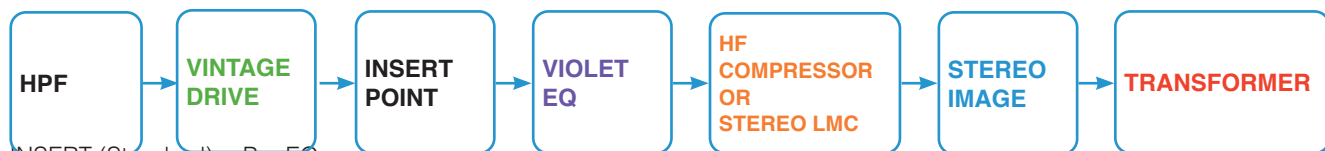

## Processing In Detail

Remember, a number of Fusion's circuits are level-dependent and this will affect the sound you get. Depending on how loud or quiet your mix already is, you may need to start by adjusting the **INPUT TRIM** in order to achieve the best possible gain-staging. As a guide, adjust the **INPUT TRIM**, or **DRIVE** control until the **VINTAGE DRIVE** tri-colour LED consistently lights green, with occasional flickers of orange. Similarly, adjust the **THRESHOLD** control (in the **HF COMPRESSOR** section) so that it only occasionally flickers green in response to sibilance and harshness. Use the **OUTPUT TRIM** to compensate for any significant level increases and retain a sensible output level that does not clip your audio interface converter inputs. This section will go into detail about each front panel section.

## O/LOAD (Overload)

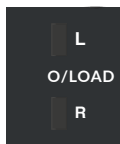

Left and Right Overload LEDs light red if the signal at Fusion Processing's input exceeds +27dBu.

## Input Trim

The **INPUT TRIM** provides  $\pm 12$ dB gain at the input stage of Fusion. This pot is indented at the 12 o'clock position. Use this control to achieve the best gain-staging through Fusion. Try starting with the pot at the indented 0 dB position if at the beginning of a the mixing process. If using Fusion with a 'hot' mix that is already approaching the kind of levels for delivery to Mastering, try pulling back the **INPUT TRIM** by 2-4dB first. If using Fusion to add character to an individual stem, try increasing the **INPUT TRIM**, which will in turn drive the following **VINTAGE DRIVE** section even harder if engaged.



## HPF (High-Pass Filter)

The High-Pass Filter allows the reduction of sub frequency content in a mix. The filter is a 3rd order/18dB per octave slope. The pot is stepped and allows a choice between four fixed settings - **OFF**, **30HZ**, **40HZ** and **50HZ**. **OFF** or **30HZ** are often suited to whole mix material, whilst the 40Hz and 50Hz can help remove unnecessary rumble when processing individual instrument stems. Removing this low-energy from stems can give back some headroom in the overall mix.



*HPF Plots - OFF, 30Hz, 40Hz, 50Hz.*

## The 6 Colour Circuits

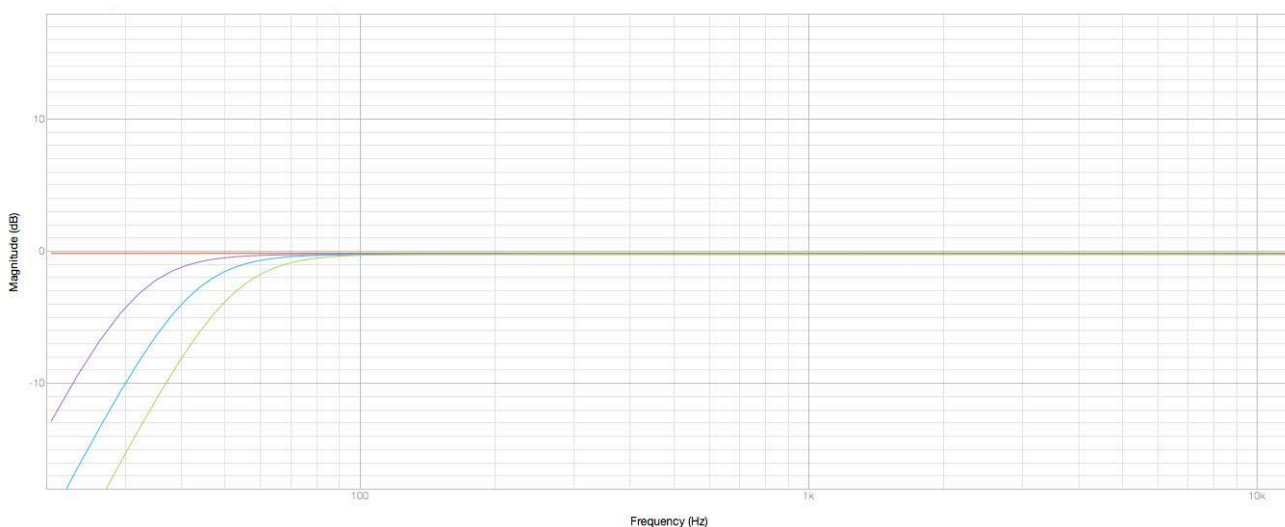

The descriptions that follow cover each of Fusion's 6 colouration circuits. Each circuit has an associated **IN** switch which

allows you to switch that particular circuit in or out. When a circuit is on it turns orange. When bypassed, the switch is backlit a soft white colour.

## Vintage Drive

**VINTAGE DRIVE** is a unique, non-linear saturation circuit that gives your mix added strength and cohesion. This circuit has been designed to bring the kind of cherished 'gradual analogue overload' sound that the best kind of vintage analogue outboard and consoles offer when you drive level into the sweet spot.



Use the **DRIVE** pot to work the **VINTAGE DRIVE** section harder. You increase the drive by moving the pot from left to right - front-panel marking 1 is least amount of drive, 11 is the most. This control automatically compensates for the level increase at the output of the **VINTAGE DRIVE** circuit. A tri-colour LED accompanies this section and provides feedback as to how hard the circuit is being driven.

If you are looking for a subtle effect that works across a whole mix, keep the LED in the green zone (occasional flickers into orange are fine). If you want a more aggressive colour, then drive the circuit until the LED starts showing orange more consistently. When in the red zone you will notice quite obvious distortion which isn't desirable across a mix bus but can work well on individual stems.

The **DENSITY** pot is used to fine tune the type of effect the circuit produces. Lower settings (generally below 3) produce additional harmonics with an emphasis towards even-order harmonics. **DENSITY** settings between 2 and 3 can help add richness to a mix. Medium to higher **DENSITY** settings from 3 onwards, result in a gradual lowering of the overall harmonic content but with the odd-order harmonics eventually becoming more prominent than the even-order harmonics. The third harmonic is related to the saturation/analogue clipping effect that this circuit imparts. This can be thought of as a kind of 'soft-compression' - peaks are rounded and the RMS (average) level is brought up. This helps you gain some additional 'loudness'. Settings between 3 and 7 work well for thickening whole mixes.

Please note that some additional low-level 'hiss' (very similar to tape hiss) is introduced when the Vintage Drive circuit is engaged. This is an integral part of the saturation effect this circuit provides and cannot be turned off. By design, the level of hiss decreases as you increase the **DRIVE** and/or **DENSITY** controls. In certain mix situations or productions you may want to minimise the amount of hiss to achieve a 'cleaner' sound (normally on quiet passages at the beginning or end of a song). In these situations the recommended workaround is to increase the **DRIVE** control in the **VINTAGE DRIVE** section and decrease the front-end **INPUT TRIM** control, to leave you with the same overall effect but with less hiss.

---

*TIP 1: The DENSITY control does raise the overall level of the signal, as you move it from MIN to MAX. Be sure to use the OUTPUT TRIM control to compensate.*

---



---

*TIP 2: A good starting point for the controls of this circuit is DRIVE at 5 and DENSITY at 5. However, the DRIVE setting will be very much dependent on how loud/quiet your mix is already.*

---



---

*TIP 3: The lowest DENSITY setting marked MIN offers a dynamic 'expansion' effect when driven hard with the preceding DRIVE control. It works well to accentuate individual stem sounds that are already dense - e.g. bringing the pluck out of a distorted bass guitar. For full mixes, it is recommended to go no lower than 2 with the DENSITY setting.*

---



Example of additional harmonics generated using a 1kHz tone. ('Low' Density)

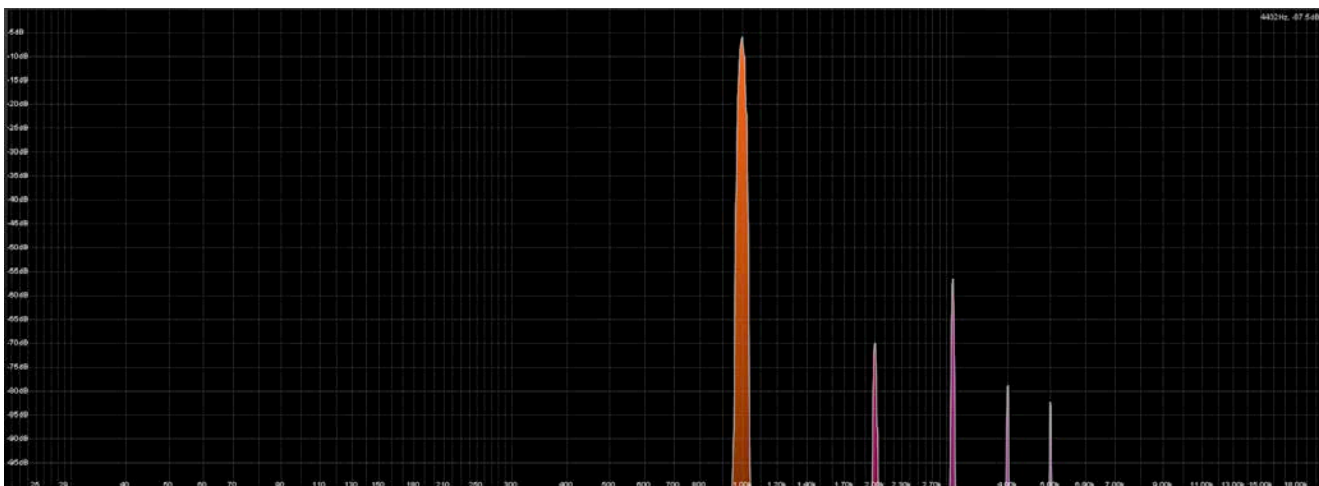

Example of additional harmonics generated using a 1kHz tone. ('High' Density)

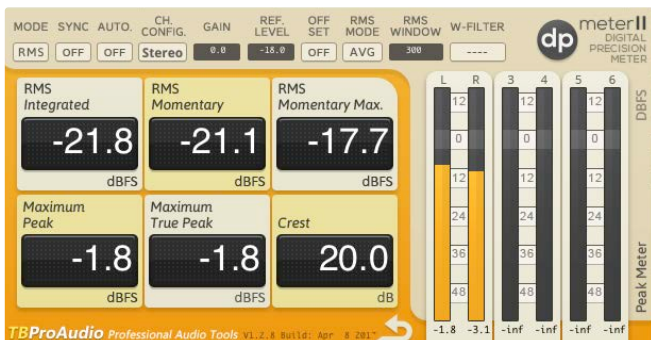

VINTAGE DRIVE bypassed.

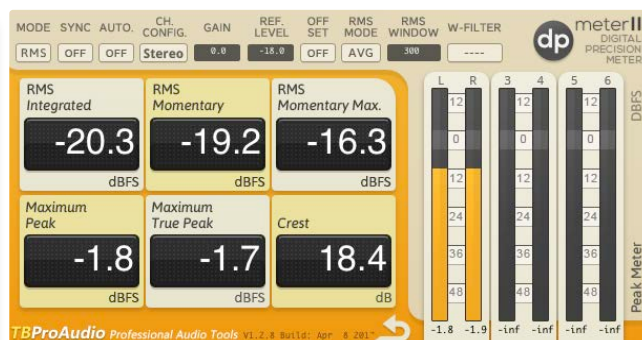

VINTAGE DRIVE engaged.

Example of the saturated compression effect introduced by medium to higher Density settings. Right-hand readout shows Fusion decrease the RMS level, with same Maximum Peak.

## Violet EQ

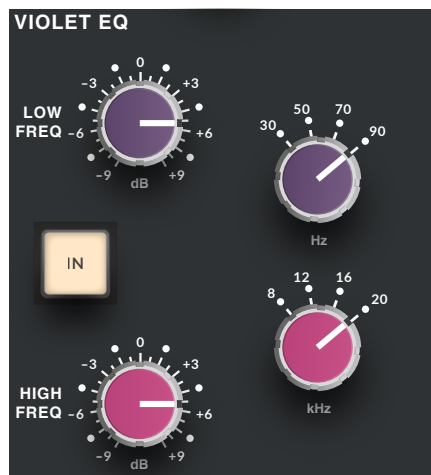

The **VIOLET EQ** draws on the SSL legacy of carefully selected frequencies and response curves to create a musical and intuitive EQ, designed to quickly dial in low-end weight and high-end sheen. The design is based upon minimum-phase shift shelving filters. The frequency pots for each band are stepped. The **LOW** band offers choices of 30Hz, 50Hz, 70Hz or 90Hz. The **HIGH** band offers choices of 8kHz, 12kHz, 16kHz and 20kHz. The gain pots are continuous, with indents at the 12 o'clock position (0dB) and allow for  $\pm 9$ dB of gain. Full mixes tend to benefit from a modest amount of 30Hz, 50Hz or 70Hz to add weight, whilst 8kHz and 12kHz are good starting points for adding tasteful amounts of high-end. One of the most-common practices in production is to mix into an EQ that adds a little bit of top and bottom-end and with the Violet EQ, SSL have designed a stereo EQ designed specifically for that purpose.

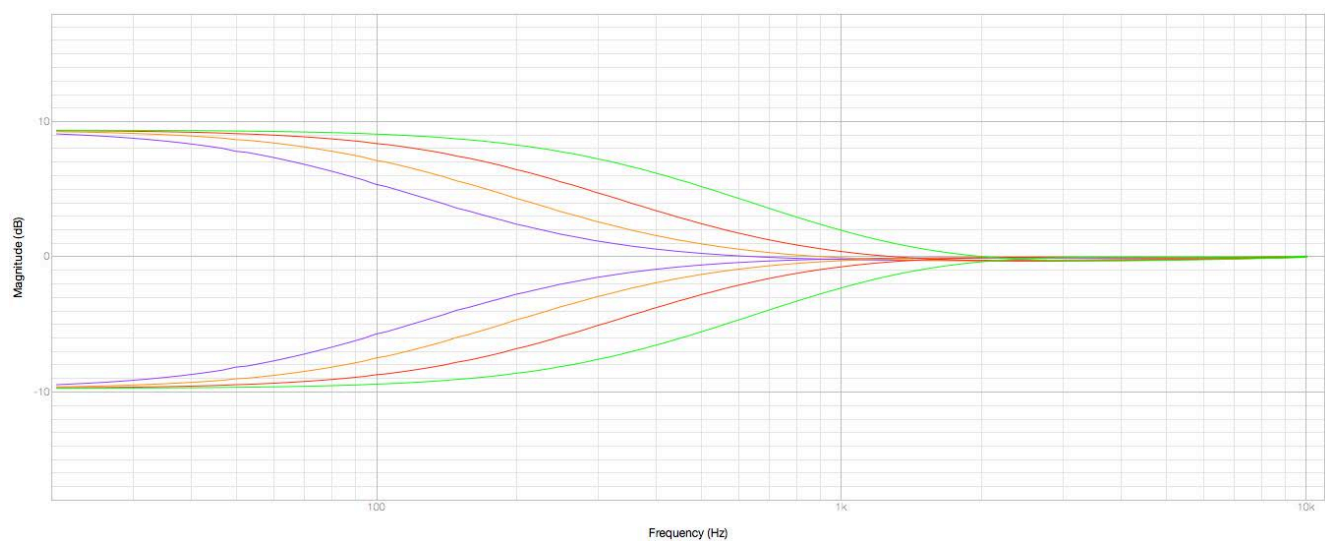

Maximum Gain plots of Violet EQ - 30 Hz, 50 Hz, 70 Hz and 90 Hz.

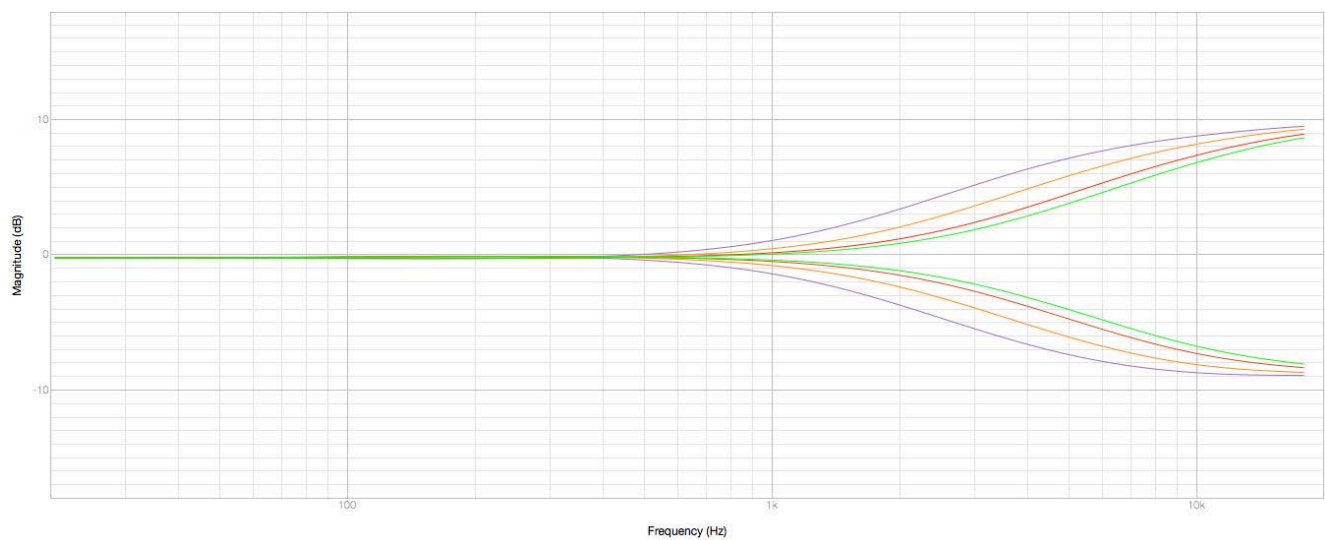

Maximum Gain plots of Violet EQ - 8 kHz, 12 kHz, 16 kHz and 20 kHz.

## HF Compressor (High Frequency Compressor) and Stereo LMC (Listen Mic Compressor)



### HF Compressor

As its name implies, the **HF COMPRESSOR** is a compressor circuit that only compresses high-frequencies. It helps to introduce a 'tape-like' top-end roll-off by taming unwanted brittleness or harshness that can sometimes build up in a mix or individual stem sound. The cause might be due to over-use of plug-ins with top-end 'hype'. The front panel **THRESHOLD** determines at what point compression starts to occur, whilst **X-OVER** determines the frequencies that are affected by the compression. Other typical compressor parameters such as attack, release and ratio are all fixed in the design, having been optimised for the best transparency.

A good starting point for full mix material is **THRESHOLD** at +2dB and **X-OVER** around 15kHz. The best approach is to move the controls until the accompanying **HF COMPRESSOR TRI-COLOUR LED** just starts to flicker green occasionally. A sustained green, into orange will likely be too heavy-handed for most mixes. It must be noted that there is no automatic makeup gain, as commonly found on digital single-band compressors. Another important point to note is that if the mix is already well balanced and mixed, engaging this circuit may not be needed at all! However, when used subtly, it can smooth harshness off in a very pleasing way. It can be used more aggressively on individual stems such as bass guitars or drums.

*TIP: A nice trick is to deliberately apply more high-end than you would normally in the preceding **VIOLET EQ** section (apply more gain on your chosen **HIGH** frequency) and then use the **HF COMPRESSOR** to tame it back. This can often help achieve a brighter top end, without the harshness.*

### Stereo LMC (Listen Mic Compressor)

The **HF COMPRESSOR** circuit can be quickly re-configured to become a full bandwidth, stereo **LISTEN MIC COMPRESSOR**. Pushing and holding the HF Compressor **IN** button for five seconds switches to 'full band **STEREO LMC** mode'. This mode is indicated by the **IN** button for the section changing from a Yellow/White light (as with the other **IN** switches) to a Blue/White colour. When in **LMC** mode, the **X-OVER** knob turns into a '**WET/DRY**' control — providing significant full bandwidth stereo compression with with parallel balance control between clean and compressed signals.

*The SSL LMC (Listen Mic Compressor) — whose origins derive from the famed SSL 4000 series consoles — was a 'secret weapon' among producers and many say was the catalyst for that 80's drum sound, which prominently features on tracks of the era, including the classic 'In The Air Tonight' by Phil Collins. Originally designed to prevent overloading the return feed from a studio communications mic, the LMC's fixed attack and release curves were soon discovered to be eminently suitable on drums, and equally interesting on guitars, vocals and many other instruments.*

### Stereo Image

The **STEREO IMAGE** circuit allows for true mid-side processing within Fusion. Mid-Side (M/S) is a technique commonly used in mastering that separates a stereo signal into 2 channels - one for the sounds in the centre (mid) of a stereo image and



the other for the sounds on the edges of the stereo image (side). The **WIDTH** allows you to increase the level of the side signal only, to generally widen or narrow the stereo image. The **SPACE** control allows you to experiment with a broad boost or cut of bass frequencies in the side signal and this feature is based upon the often overlooked but quite brilliant 'Stereo Shuffling' processing technique. Many people think of wanting to remove bass from the side signals but this **SPACE** control may have you re-thinking that approach as you can inject some really interesting depth effects into the mix. **SPACE** settings beyond +4dB on whole mixes may be too extreme, so try between +2dB and +4dB to start with.

## Transformer



Fusion features a custom-designed SSL **TRANSFORMER** circuit, which is engaged via the front panel transformer switch. This circuit does a number of things: The 600Ω, 1:1 winding transformer and surrounding circuitry adds low-end harmonic content and a favourable slight top-end phase-shift to the sound. Furthermore, the underdamping of the transformer adds a subtle 'weight' to the sound. It is worth noting that the drive of the transformer circuit is self-contained, so there is no advantage in driving the Input stage of Fusion to achieve more level through the transformer. Also, as is inherent with transformer designs, extreme low-end frequencies begin to be rolled off, the more level is put through - so bear this in mind. Typically, a level of +16dBu will see a 0.5dB roll off between 40Hz and 30Hz and this is quite often (but not always!) welcome in keeping the bottom-end in check. Experiment with engaging the transformer at any point during the mixing process to see if it makes the mix sound better (it often does).

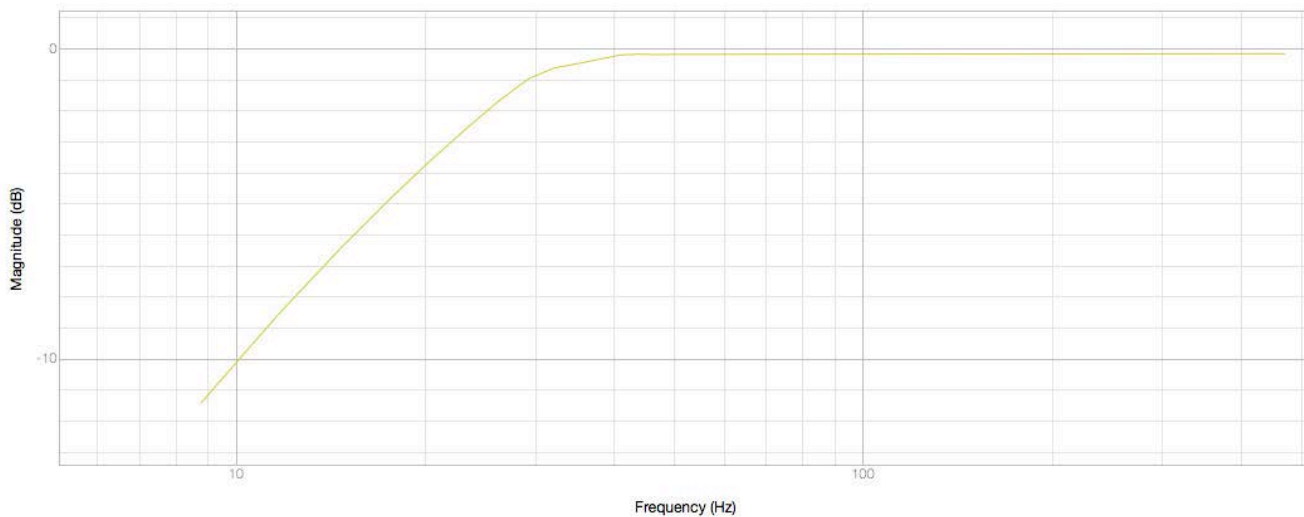

*Typical Low Frequency Rolloff of Transformer with +16dBu on input.*

## Stereo Insert

### Insert (Standard Mode)



The Fusion processing Section features a stereo insert point, which provides the ability to introduce other outboard processors. The insert point is engaged via the front panel **INSERT** switch and will light bright white when operating in standard stereo mode. The **PRE EQ** switch allows for the insert point to be moved before the **VIOLET EQ** section in the signal path.

### Insert (M/S Mode)



Pressing and holding the **INSERT** switch for two seconds will cause it to enter **MID-SIDE MODE**, indicated by the front panel switch(es) turning blue. The **INSERT SEND** and **RETURN LEFT** connections become the 'Mid' channel insert and the **INSERT SEND** and **RETURN RIGHT** connections become the 'Side' channel insert. This provides the option of using one piece of mono outboard equipment to process the mid signal only and another to process the side signal (a common mastering technique). Pressing the **PRE EQ** switch in this mode moves the insert to be before the Stereo Image circuit. By default, it is post the Stereo Image circuit.

## Bypass Modes

### Bypass (Standard Mode)

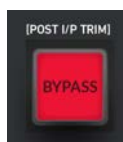

The **BYPASS** switch provides a simple way to bypass all of Fusion's processing blocks. If the **BYPASS** switch is red, then the section is in standard **BYPASS** mode. Use this to compare the sound of the mix with/without Fusion in one easy action. It dimly lights white if you are not in bypass.

### Bypass (Post I/P Trim)

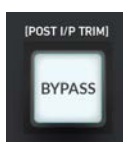

Pressing and holding the **BYPASS** switch for two seconds will cause it to enter **POST INPUT TRIM** bypass mode. In this mode the front panel switch will turn bright white and the INPUT TRIM pot still affects the sound, even in bypass. This mode is a useful extra feature if there's a need to make-up or take off significant amounts of gain using the INPUT TRIM.

## Output Trim



The **OUTPUT TRIM** provides  $\pm 12$ dB gain at the output stage of Fusion. This pot is indented at the 12 o'clock position. This control is important in order to compensate for any level increases caused by the preceding sections.

### Master Meter

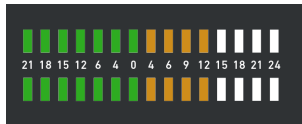

A master meter, with three second peak hold allows you view the main output level of the Fusion processing. The scale is referenced in dBu, with +24dBu at the top. This meter is pre the **PRECISION IMAGE ADJUST** control.

*TIP: When BYPASS is engaged, the master meter automatically becomes an input level meter, so you can see incoming levels in more detail.*

### Front Panel Switch Haptic Feedback (Button Clicks!)

The switches used in the Fusion processing section are solid state switches that trigger a single relay for sensory feedback. The benefit of this ‘solid state’ approach is that it allows for the front panel switches to be repurposed for additional functions, such as settings and secondary switch modes (M/S mode on the Insert Switch for example). The relay provides acoustic feedback for a traditional ‘analogue’ feel. The relay feedback can be switched off in the Settings Mode, specified later in this section.

### Precision Image Adjust

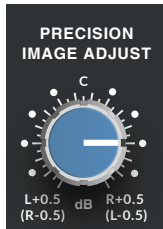

With cascaded Stereo signal processes and features such as M/S Insert processing, it’s possible that fractional offsets in the stereo balance can be introduced in the stereo mix bus processing signal chain. The **PRECISION IMAGE ADJUST** control provides a precise tool to compensate for these. This is a stereo balance control with a +/- 1 dB level adjust for both Left and Right stereo signals. The control is a precise stepped potentiometer controlling a stereo SuperAnalogue MDAC circuit, for the ultimate in precise, repeatable balance adjustment.

### Fusion Routing Switch



The **FUSION ROUTING SWITCH** controls where the Fusion Processing is placed in the bus architecture of the Duality Fuse console. There are three options, firstly in the Insert Return of Duality Fuse’s Mix A bus (**MIX A LED** lit), the second is in the Stereo Submix Insert Return (**STEREO SUBMIX LED** lit) and the third option is ‘unrouted’ (no LEDs lit), i.e. the inputs and outputs need to be manually patched. The options are selected by repeated pressing the **FUSION ROUTING** button.

Ultimately the signal routing is determined by the wiring of the console and possibly the layout of the patch bay, but if the console is wired to SSL’s recommended patch layout then the notes on the following pages will describe the signal flow in detail.

### User Switches



At the bottom end of the Fusion Processing section are a set of four **USER SWITCHES**. These control relay closures and the LED illumination can be either locally switched or illuminated from a separate ‘talley’ input.

These switches can be either non-latching or ‘SSL’. The SSL mode is a combination where a short press latches the switch on or off, whereas a long press is non-latching. This can be a useful mode for communications functions.

### User Switch Mode Programming

A long (5 second) press on the **FUSION ROUTING** switch will put the **USER SWITCHES** into ‘programming’ mode. This is indicated by the **MIX A LED** flashing quickly and this mode is used to determine whether the **USER SWITCHES** are non-latching or ‘SSL Latching’. If the **USER SWITCH** is Latching its LED will be on solid, if its LED is off, then it’s in SSL Latching mode. The SSL mode is a combination where a short press latches the switch on or off, whereas a long press is non-latching. This can be a useful mode for communications functions. To escape the User Switch Programming Mode use a quick press of the Fusion Routing key.

The wiring detail of these switches can be found in the Duality Fuse Installation Guide, available for download from the SSL website: [www.solidstatellogic.com](http://www.solidstatellogic.com)

## Fusion Signal Routing

There's an assumption in the diagram below that the Fusion wiring for the Duality Fuse console is connected to a Patchbay along the recommended lines from the Duality Fuse Install Guide.

## Patchbay and Signal Routing

While it is feasible to use Duality Fuse without a patchbay, it does restrict the flexibility of how the console can be configured and this extends to the flexibility of the Fusion patching.

The diagram below shows the relationship between the patchbay wiring and the signal routing through the Fusion Processing. As can be seen below, the Fusion Processing is in the Mix Bus Insert Return signal path. If the Fusion is being used in **MIX A**, then the **MIX A INSERT** function needs to be selected on the switch matrix (shown on the right) as well as the **MIX A** routing with the **FUSION ROUTING** switch. If the console is in **5.1 MIX** mode, with the **MIX A FUSION ROUTING** option selected (shown with the **MIX A LED** on), the Fusion Processing will be in the Left/Right front buses, if the **FUSION ROUTING** has the **STEREO SUBMIX** selected, the Fusion processing will be in the Stereo Fold-down of the 5.1 buses. If there are no LEDs lit in the **FUSION ROUTING** display, then the Duality Mix Insert returns are routed directly from the Patchbay to the console. This means there is no signal routed to the Fusion processing by default and it can be patched wherever it is needed. Some examples of useful routing are shown on the next pages.

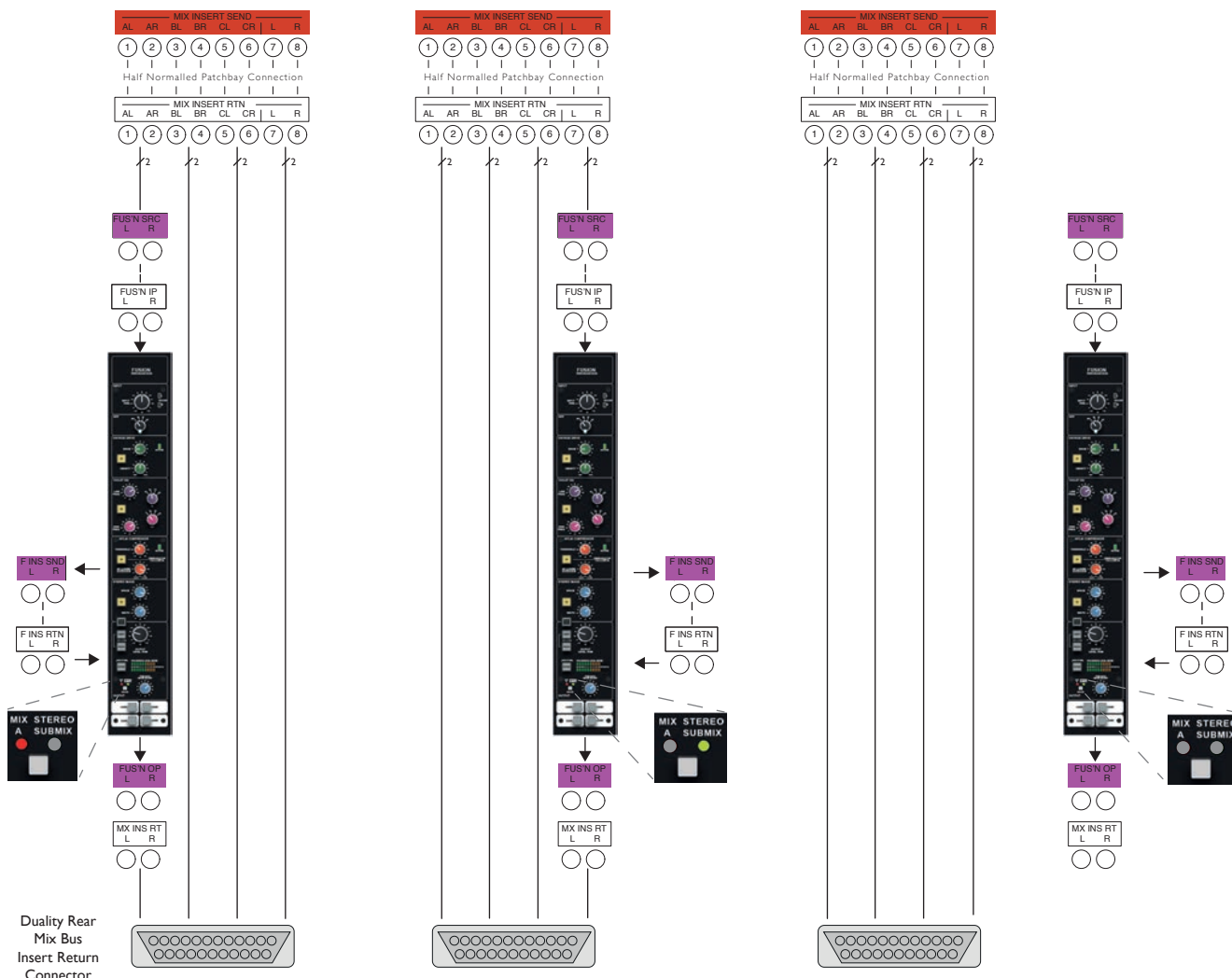
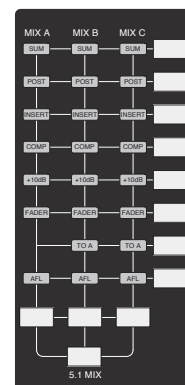

# Fusion and Mix Bus Inserts

The block diagram below shows how the Fusion Processing is related to the Mix Bus Inserts and Duality's Bus Compressor.

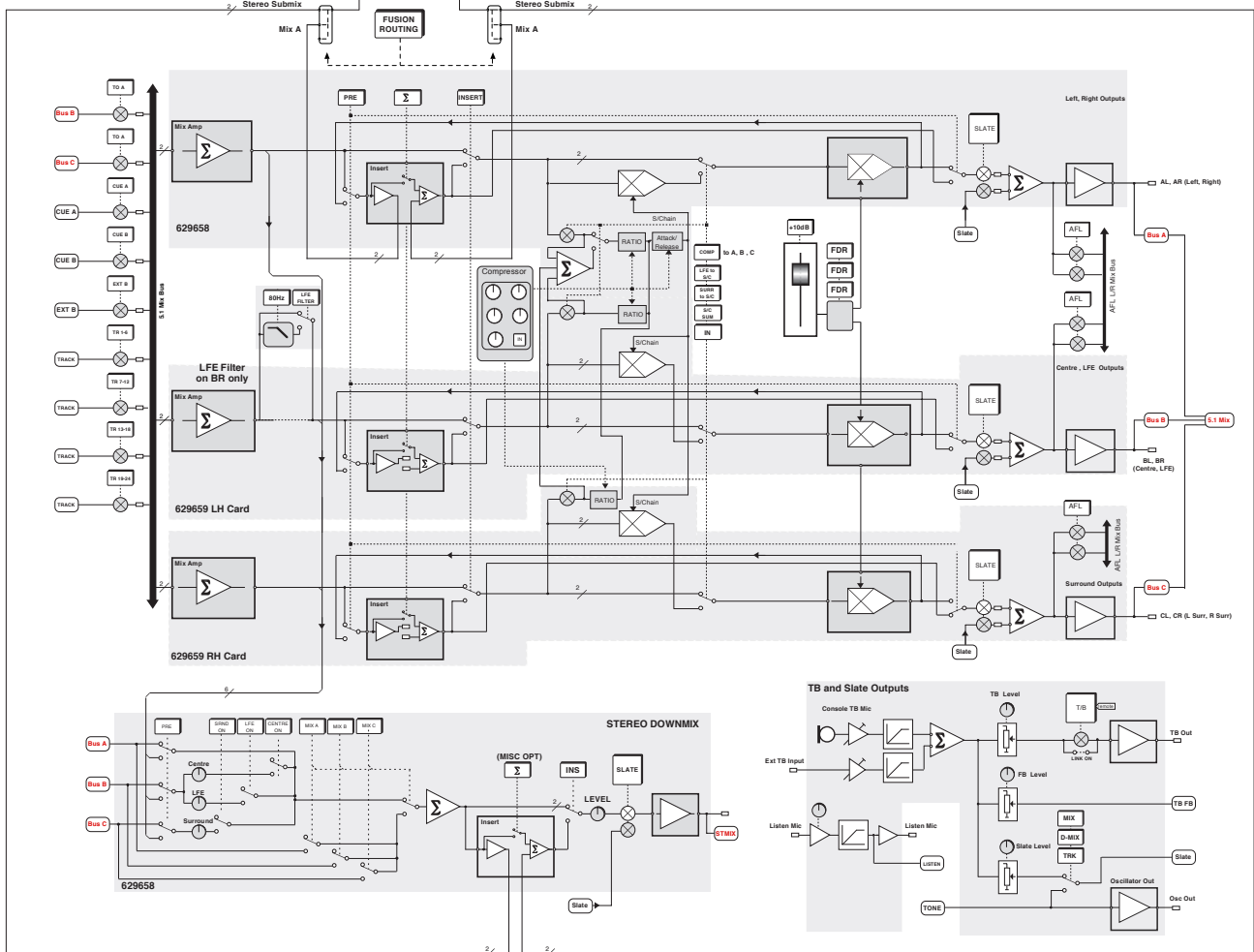
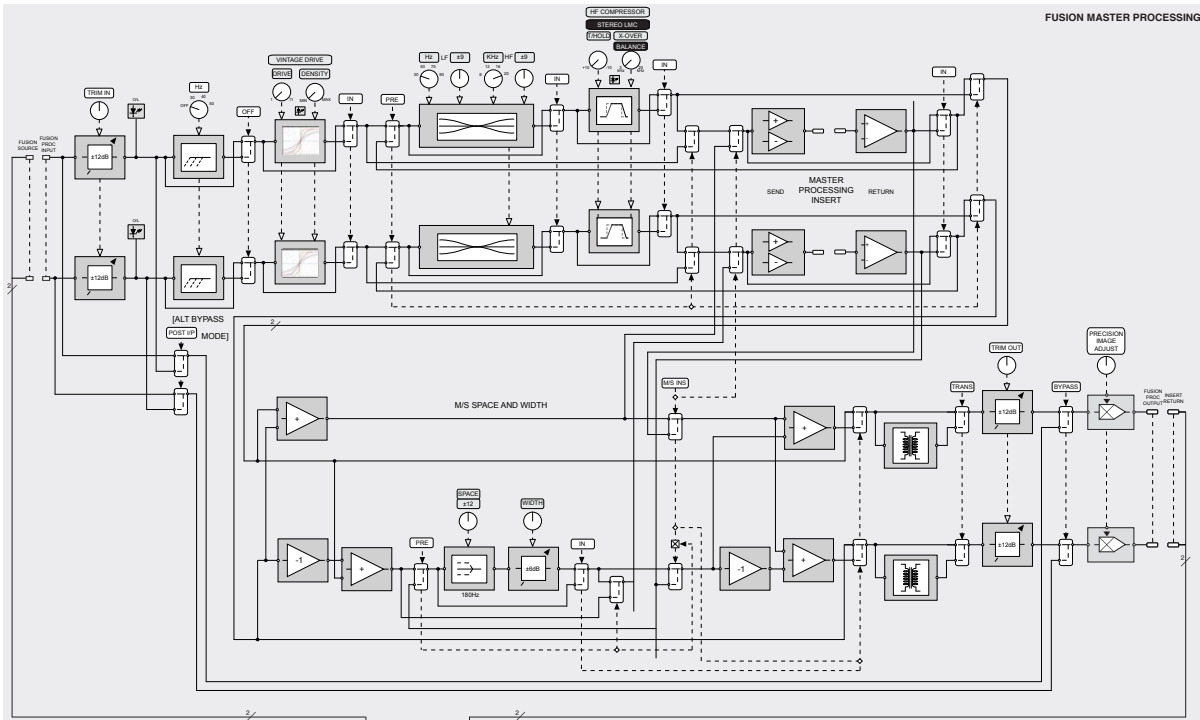

## Fusion Signal Flow Examples

Here are some diagrams to help understand the signal flow (assuming SSL recommended Patchbay wiring).

### Fusion processing routed to MIX A with Bus Compressor AFTER Fusion Processing.

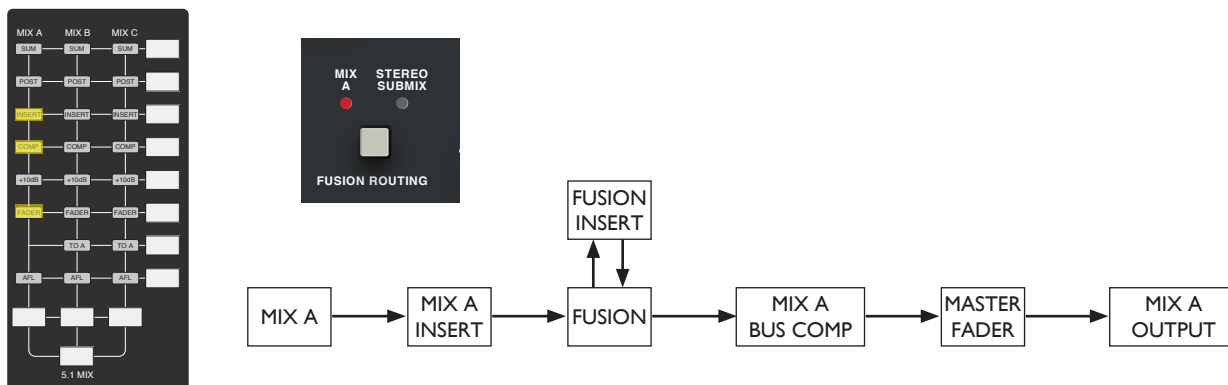

### Fusion processing routed to MIX A with Bus Compressor BEFORE Fusion Processing.

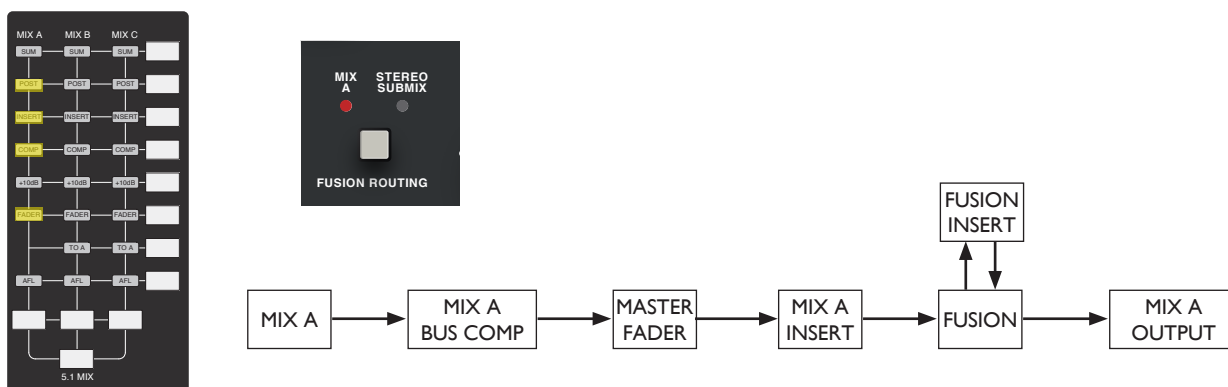

### Fusion processing routed to STEREO SUBMIX.

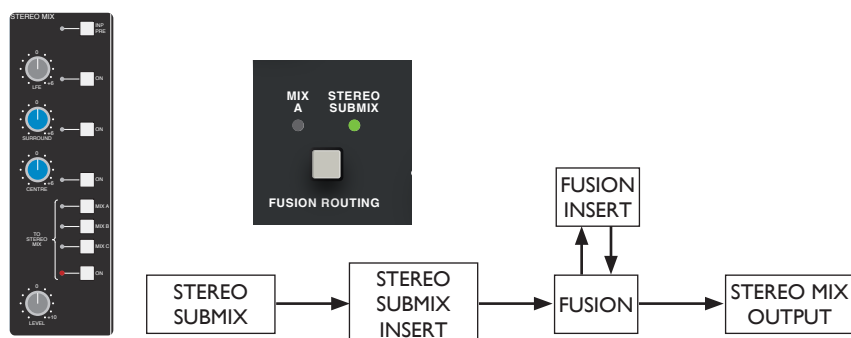

### Fusion processing - Independant routing.

With both of the FUSION ROUTING LEDs off, the Mix Bus Insert points are connected directly and the Fusion processing is able to be patched across any stereo source/insert required

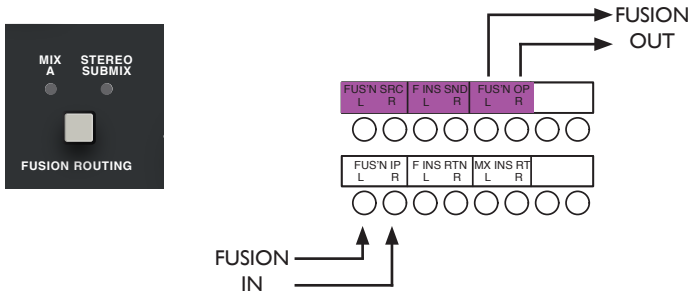

### Fusion processing - Independant routing, patching into Mix B (or Mix C).

Again, to allow independant patching both of the **FUSION ROUTING** LEDs are off. The Fusion Input and Output Patchpoints are simply patched across the Mix B (or Mix C) Insert Sends and Returns e.g.

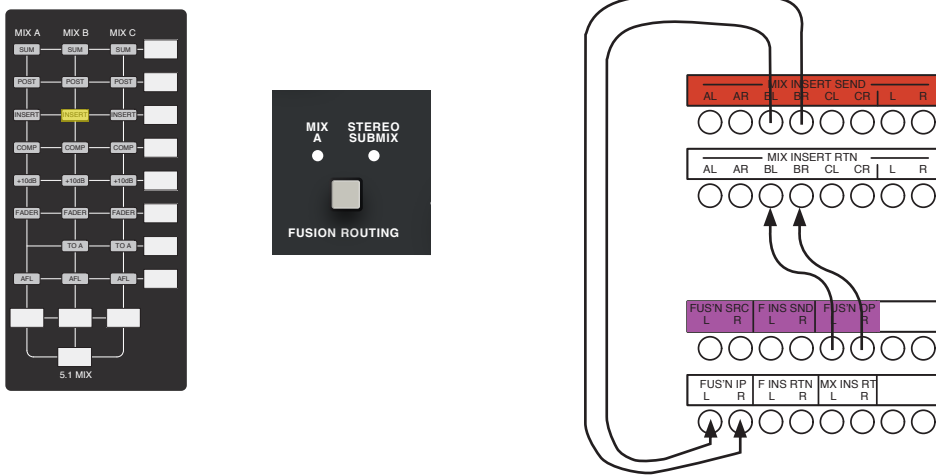

## Settings Mode & Factory Reset

This section will detail how to enter Fusion processing section's Settings Mode and the functionality that can be changed. It also details how to reset Fusion processing back to a factory default state.

### Entering Settings Mode

To enter the Settings Mode, switch the unit on then hold down the **TRANSFORMER** and **BYPASS** switches during the startup LED sequence. In this mode it is possible to modify some parameters of the unit. These parameters will be recalled each time the console or section is rebooted.



### Meter & Switch Brightness

Whilst in Settings Mode, it is possible to select five levels of brightness for the meters and switches.

- To decrease the brightness, press the **VINTAGE DRIVE IN** switch.
- To increase the brightness, press the **VIOLET EQ IN** switch.

If the VINTAGE DRIVE IN switch is not lit, minimum brightness is reached. If the **VIOLET EQ** switch is not lit, maximum brightness is reached. Factory setting: maximum brightness.

---

*Note: The brightness setting does not affect the startup LED sequence, or signal indicator LEDs found in the **VINTAGE DRIVE** and **HF COMPRESSOR** sections.*

---

### Relay Feedback

Whilst in Settings Mode, it is possible to enable or disable the relay feedback of the switches. This affects the startup sequence and normal operation.

To switch between enabled and disabled, press the **INSERT IN** switch.

- If **INSERT** is dimly lit white, relay feedback is disabled.
- If **INSERT** is lit blue, relay feedback is enabled (a quick relay transition is reproduced as confirmation of the setting).
- Factory setting: relay feedback enabled.

### Exiting Settings Mode

To exit Settings Mode, press and hold the BYPASS switch until the unit reboots.

## Factory Reset

To reset Fusion to factory settings, switch the unit on then hold down the VINTAGE DRIVE IN and BYPASS switches during the startup LED sequence.



Factory Reset allows reset of any stored settings (Brightness, Relay feedback, **BYPASS** and **INSERT** configurations) to the factory default. Press and hold the combination of switches until all the switches start flashing. After releasing the switches, the unit will automatically reboot and the factory settings will be restored.

## Simon Says Game

To play the Simon Says game, switch the unit on and hold down all four IN switches during the startup LED sequence.

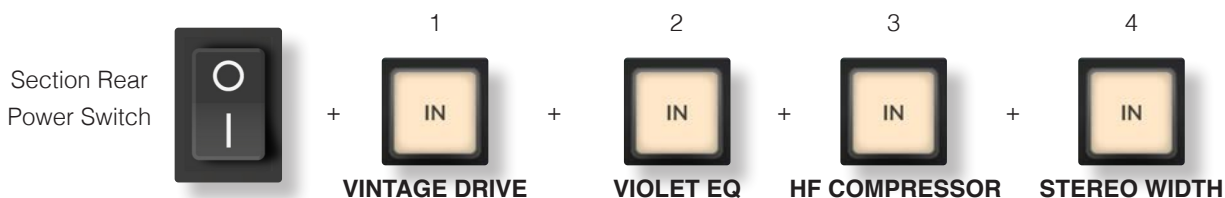

The **BYPASS** switch will flash red. The highest score achieved on the unit is shown on the master meters; the right bar meter is points x1, the left bar meter is points x10 (e.g. two LEDs lit on the left and six LEDs lit on the right means that the current highest score is 26). If the maximum score is reached, the two top red LEDs are lit. Factory reset does not affect the highest score for the unit.

Press the flashing **BYPASS** switch to start a round.

A random switch between the first four switches will light up briefly (The relay will also click a number of times equal to the position of the switch; switch 1 = 1 click, switch 2 lit = 2 clicks etc).

The aim of the game is to press the correct switch within four seconds. If the wrong switch is pressed or a timeout of four seconds elapses, the game resets.

If you press the correct switch, you move to the next level and another switch is added to the sequence.

---

*Note: Every three levels the difficulty increases by displaying the sequence faster. To exit this mode, power-cycle the unit.*

---

# Fusion Section - Other Settings

## UID Display Mode

UID Display Mode displays the UID number of the firmware currently in use and the hardware revision of both main card and front panel card. To enter UID Display Mode, switch the unit on and hold down the **PRE EQ** and **BYPASS** switches during the startup LED sequence.



## Unique ID (UID)

The UID is a five digit number. Pressing any of the first five front panel switches allows the selection of any of the five digits of the UID. The selected digit will be represented on the right main meter bar (see table below).

0 LEDs on	current digit is 0
1 LED on	current digit is 1
2 LEDs on	current digit is 2
...	...

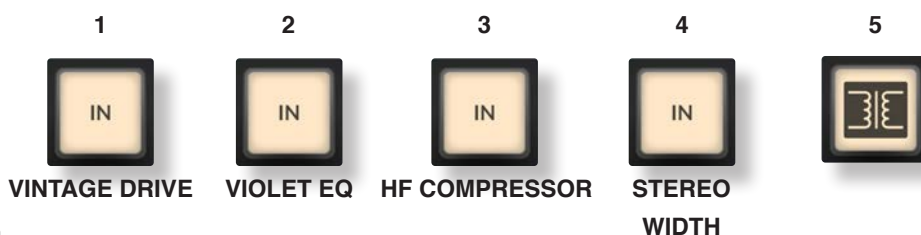

## Hardware Revision

To display the hardware revision of the boards, press the **PRE EQ** switch whilst in UID Display Mode (which will light up blue). On the left meter, the mainboard revision number is displayed (see table below). On the right meter, the front panel revision number is displayed (see table below).

0 LEDs on	current digit is 0
1 LED on	current digit is 1
2 LEDs on	current digit is 2
...	...



Press & Hold of the **BYPASS** switch will force the unit to reboot.

## Soak Mode

In soak mode the unit will cycle through all possible colours and modes of LEDs, to allow verification of the unit. To enter Soak Mode, switch the unit on and hold down the **INSERT** and **BYPASS** switches during the startup LED sequence.

The **HPF** rotary encoder allows you to stop the cycle on an arbitrary step if set to the “**OFF**” position. Setting the **HPF** rotary encoder to any other position will cause the cycle to run again. The higher the position, the faster the pattern will cycle through.

Press & Hold of the **BYPASS** switch will force the unit to reboot.

# Fusion - Block Diagram

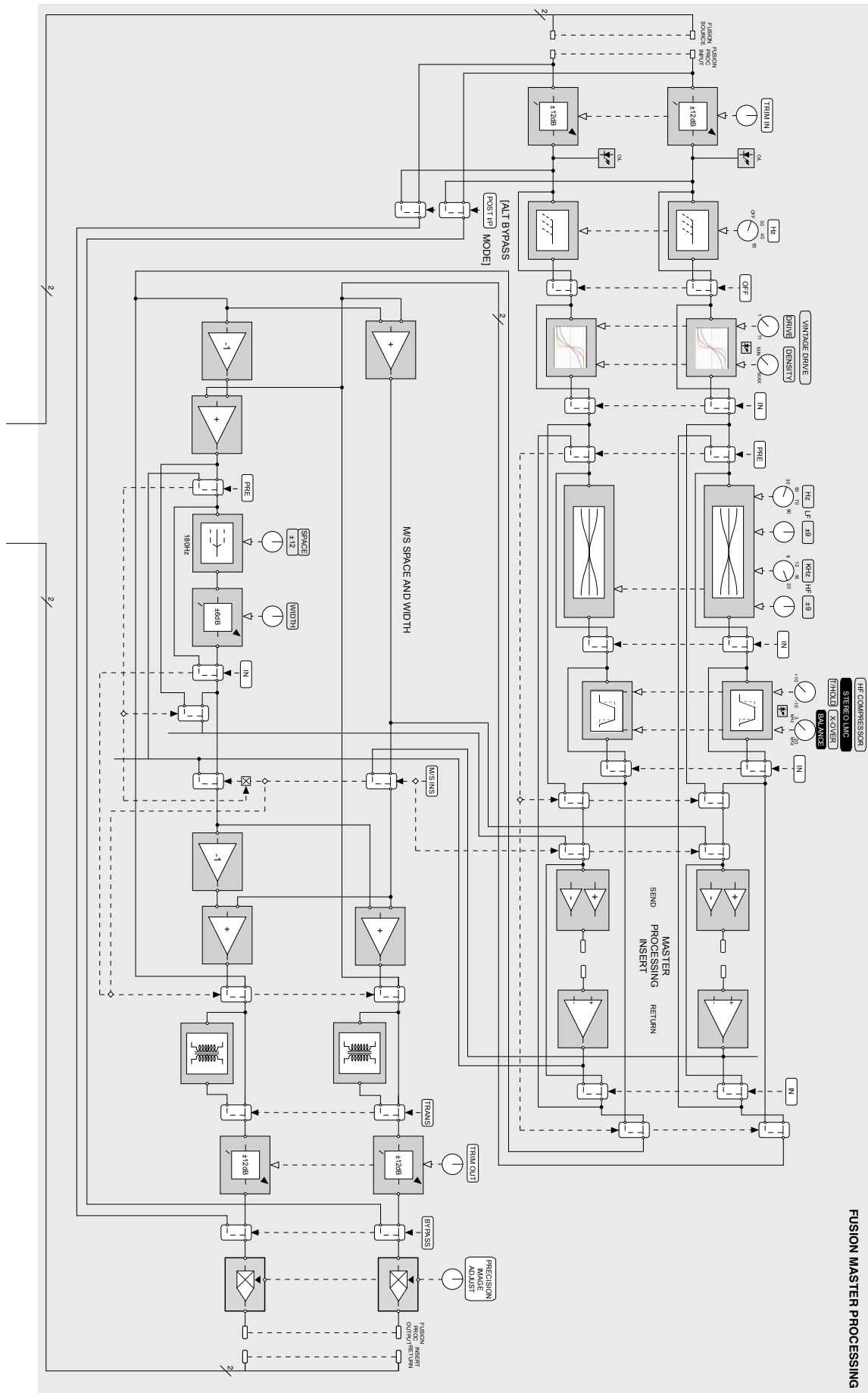

## Fusion - Recall Sheet

As the Fusion Processing section uses identical circuitry to the rack mount original, the Fusion section isn't scanned or stored by the Duality recall software. This sheet can be used to capture settings for recall.

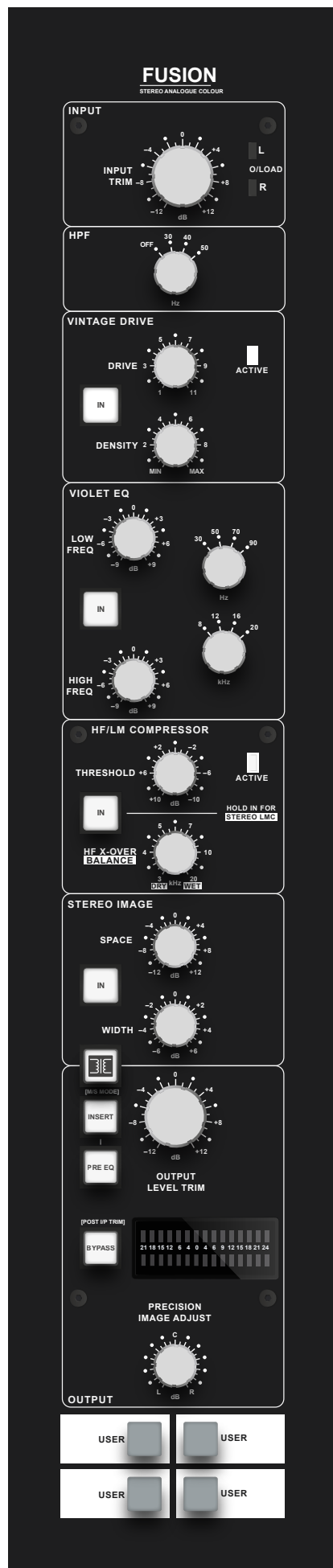



# *Duality Fuse*

**Operator's Manual**

**SECTION 8:**

**System Block Diagrams**

# Contents

<b>Appendices</b> .....	<b>A-3</b>
<b>1. AFADA</b> .....	<b>A-3</b>
<b>2. Block Diagrams</b> .....	<b>A-4</b>

# Appendices

## 1. AFADA

A-FADA (Analogue Fader Accesses DAW Automation) utilizes the automation system of a DAW to control the analogue channel levels by linking the DAW fader and mute data to the console's channel level and cut functions. It has been superseded by  $\delta$ -Control which offers far more flexibility and operational benefits than A-FADA without any of the limitations such as being limited to 32 console channels (Pro Tools HUI) or having to use only the standard DAW mix commands available from a MIDI connected hardware control surface.

The descriptions below are for information only as the A-FADA command keys can still be found in the **SSL / DAW** menu together with the DAW 1 and DAW 2 select keys.

A-FADA is enabled in the TFT screen by selecting **SSL / DAW**, and then selecting **DF 1** or **DF 2** (control from DAW Layer 1 or Layer 2). If you then play the DAW automation or move an on-screen fader, you will see the analogue faders move – these movements are affecting the analogue signal levels within Duality.

---

*If only one DAW option is available, you have only set-up one DAW layer in the SSL > Misc > Setup menu.*

---

The console's analogue faders are controlled by the automation information from the DAW tracks assigned to channels 1- 32 (or up to 48 if MCU control is used). The automation data is applied to the signal path assigned to the channel fader, regardless of the DAW channel formats.

---

*If Single Layer is selected in the SSL > Misc > Setup menu, placing both DAW layers on the control surface at once, the SSL > Daw > DF 1 and DF 2 are linked together – either switch will activate A-FADA for both DAWs. A-FADA will follow the channel counts assigned to each DAW (also configured in the SSL > Misc > Setup menu).*

---

Once A-FADA mode has been enabled, the console faders will control the corresponding DAW faders, and the fader position signal from the DAW will control the console fader positions and analogue gain, regardless of the selected Focus mode.

In Analogue Focus the channel cut switches control the analogue cuts directly, while in DAW Focus they are routed via the DAW and will be recorded as mute automation. Analogue Focus mode allows channels to be muted as far as monitoring the mix is concerned, without writing mute automation or needing to change automation modes.

The console solo switches are connected to the analogue signal path in both Focus modes.

In order to lock console channels to the same DAW track (and thus its automation), Channel/Bank scrolling is disabled in A-FADA mode.

## SNAP

The snap function, located in the TFT screen's DAW menu, fires a snapshot of the console analogue fader positions, automatically stored when A-FADA mode is enabled. When A-FADA mode is enabled, the console faders will move to match the current DAW fader positions. Pressing the snap switch will move the faders back to the previously stored positions, allowing the analogue balance to be restored and written in to the DAW automation. Mix Conversion

## Converting AFADA Mixes

$\delta$ -Control automation replaces the AFADA automation option that was included in the Duality V4 software. To convert a mix that used AFADA simply add a  $\delta$ -ctrl Plug-In to each track in the session that was controlling a Duality channel and use the *Cut and Paste Special* edit commands to transfer the track volume automation data to the plug-in volume automation lane.

## **2. Block Diagrams**

- 1 Annotated Channel Layout
- 2 Duality Channel Strip block diagram
- 3 Annotated Centre Section Layout
- 4 Duality Master Section Block Diagram

## Duality Fuse Channel

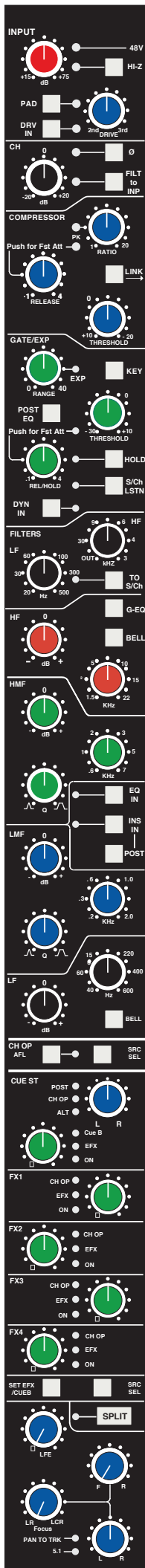

The Channel Input contains two completely independent preamp stages. Both feature electronically balanced inputs with very different but complimentary sonic qualities. The default preamp uses SSL's acclaimed Super Analogue circuitry to provide an extremely low noise, extended bandwidth front end with the minimum of signal colouration. The 'Drive In' switch routes the input signal to a completely different preamp featuring the VHD™ (variable harmonic drive) circuits developed for the E-Signature strip. VHD™ emulates the characteristics of a classic valve front end but with option to tailor the harmonic mix when the preamp is overdriven via the Drive Control. In conjunction with the PAD and Hi-Z Input impedance option, VHD™ can provide subtle valve style warmth to a mic signal or aggressive tonal shaping to existing DAW tracks. A centrally controlled Input Flip function reverses the routing of the Input and Monitor returns so that the DAW is automatically routed to the input preamp without requiring external patching.

The Channel section provides final gain trim and polarity inversion for the centrally selected channel source. Available input options are the output of the Input preamp, the balanced line level DAW return, or the channels associated track bus for patch free subgroups. FILT to INP locks the high and low pass filters to the channel source.

The Dynamics section contains a compressor section identical to that of the 9000K series and also found in SSL's Logic Fx range of outboard processing units. In normal use, the compressors true r.m.s side chain and over easy soft ratio function provide a very transparent compression action even with large amounts of gain reduction. The fast attack option offers the classic SSL compressor sound normally associated with its use on drum and percussion sources. Selecting Peak (PK) mode defeats the over easy soft ratio, modifies the release curve and attack times, and unleashes a far more aggressive sounding compressor ideal for more radical sonic shaping.

Normal the Dynamics section precedes the Equaliser and filters. Post EQ places the processing after the EQ.

The side chain monitor option routes the sidechain signal to the console AFL bus simplifying set up when either an external key input or the filters to side chain option is in use.

The Gate/Expander section is a new variant of the classic 4000 series three control design. It features the choice of a steep gate or gentle expander slope, with optional fast attack. HOLD offers a choice of the original variable release control or a new variable hold time mode with a fixed release time.

Continuously variable High and Low pass filters with individual true bypass for each section. Normally fed with the output of the eq section, dedicated switching located in the Channel section places the filters directly after the channel input. S/CH routes the filter section to the dynamics sidechain.

Four band parametric equaliser based on the classic 'Black Knob' eq developed for the original 4000E series console. The bell option for the shelving bands provides a fixed bandwidth parametric mode for each section.

G-Eq mode introduces steeper shelving curves with a controlled amount of undershoot at the turnover frequency, together with the classic gain/bandwidth interaction for the mid band sections which was a key characteristic of the original G-Series eq.

The balanced insert point has local switching to select a post eq signal instead of the default channel input signal. Additional centre section switching can place the insert post dynamics but pre eq providing complete flexibility in the order of internal and external signal processing routing. Processing order is graphically displayed on the channel TFT screen.

Normally the channel output receives the post fader, post channel mute, signal. The SRC SEL selects the alternate channel output feeds - Channel Input, Pre Fader or the active EFX send. Current source is shown on the channel TFT status display.

The Stereo Cue section routes a Pre Fader signal to a choice of two alternate cue busses, A or B. Additional source options are the Post fader channel feed, the Channel direct output or the Channel ALT input. The latter is defined as whichever input is not assigned to the main channel path and allows the stereo cue to be used as an additional line input. ON/OFF is switching is via a push push switch mounted on the send level control.

Four mono send controls feed the console Fx busses. These receive either the Post fader or Channel output signal. ON/OFF is switching is via a push push switch mounted on the send level control.

Either the Stereo Cue or any of the 4 mono sends can be nominated as an EFX send and in turn routed either to the 24 console track busses or the Channel Output.

When the Channel Output is sourced from either Input or Pre Fader, SPLIT offers a new approach to In-Line tracking on an analogue console by returning the DAW output back into the channel path just after the Channel Output pick off point. By using Input or Pre as the channel output source, clean or processed signals are routed to the DAW, with the option to use the remaining channel processing and routing to monitor the DAW return in the analogue domain.

The Channel strip contains a fully featured 5.1 panning section for both the main console busses as well as the 24 Track busses. With the most complete implementation found on any analogue console, the feature set includes a dedicated LFE send and fully variable centre divergence to vary the phantom/hard centre mix for sounds located in the front channels.



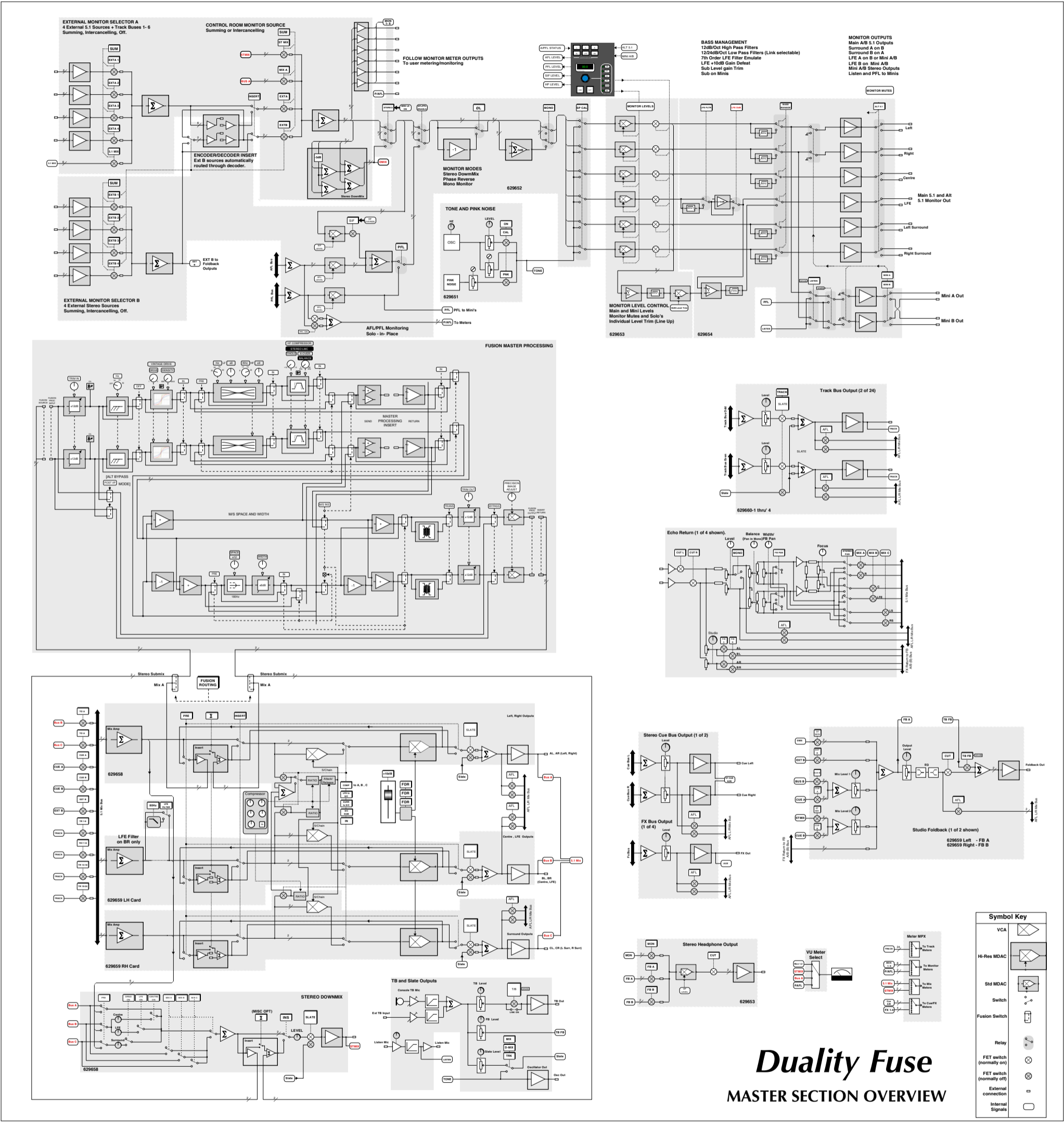

# Duality Fuse

## MASTER SECTION OVERVIEW

## Mix Reassign Matrix

Adds the selected Mix(es) post output level control to the main 6 Console Mix Busses. The three stereo mixers, the stereo CUE A & B mixes, plus the output of the stereo monitor selector, EXT B, can be reassigned to busses 1 & 2 (Mix A). The Track Busses are partitioned as four groups of 6 and re-assigned to all of the main console busses. This gives up to four 5:1 stems or four triple stereo bus sets.

## LEF Channel

Inserts a low pass filter into the LEF mix bus (bus 4 or Bus B7) when working in Surround. Two filter frequencies are provided, the default 120 Hz filter or a switched 80Hz option. Filter slope is 12dB/Octave.

## Stereo Mix Matrix

Sumns the console main mix busses with two exclusive modes of operation. The three variable controls and their associated ON switches function as 5:1 to Stereo Down mix matrix to the original 5:1 front L and R channels. Normally the Down Mix is sourced from the Main Mix bus outputs post processing and level control. INP PRE feeds the Matrix directly from the bus mix amps bypassing all processing. The MIX A, B and C switches engage the second mode of operation which is a simple buss sum of the 6 main console busses when they are used as three stereo pairs or stems. The summing is post processing and level control. The resulting stereo mix has a master level trim and a separate pre level control insert point. The insert return supports the 'SUM' option found on the Main console bus insert points but controlled via the MSC menu as opposed to a dedicated front panel key.

## Stereo Foldback Outputs

Two identical sections FBACK A & B, sum various console sources for use as Headphone or Studio monitoring feeds. Each Foldback channel receives six stereo mixes, either directly or via two independent mix level controls together with four additional dedicated stereo feeds from the Stereo Return channels. The two direct inputs are Stereo Monitor (ST MON) which is the Control Room monitor source post the fixed 5:1 down mix matrix and EXT B, the external stereo monitor selector. This provides a simple means of sending a mix or reference playback to the studio. The two mix level controls each have two selectable inputs. Mix 1 receives the CUE A and Stereo Mix A, Mix 2 receives CUE B and the output of the Stereo Mix Matrix. Via the two Mix controls, a number of simple ways are available to build headphone mixes, using the console Stereo Cue Sends and Mix busses. Each output has a master level control, high and low shelving eq and a mute(CUT) switch.

## Main Bus Control

Control of the Main Bus Insert modes, re-assign, monitoring and Compressor routing, together with assigning the front panel Master fader to the Mix outputs is through a simple row/column switch and indicator matrix. The functions are controlled by the dedicated row keys on the right of the indicator matrix in conjunction with the Mix select keys located at the base of the indicator matrix columns. The 6 main Mix busses are initially configured as three independent stereo pairs, MIX A, MIX B and MIX C. Each pair has an switchable insert point with the option to be placed pre (detail) or post level control. The insert mode permits the insert return to be summed with the main signal path. Control is via the first three rows of the Matrix. The fourth row controls the routing for the Master Bus compressor.

This functions as single stereo unit inserted via the individual MIX keys or as a 5:1 compressor in conjunction with the 5:1 MIX key. The single master fader is assigned via the Fader row either to the individual stereo mix stems or as 5:1 master fader via the 5:1 MIX Key. The master fader level can be set for unity or +10dB operation either individually for each stem or globally for 5:1 mixes. Stereo Mixes B and C can be folded into the A mix via the TO A row. Each stem can be individually monitored via the AFL row.

## Compressor

Using the same classic design as found on the original 4000 series, the main bus compressor can be used as a single stereo unit or as a master 5:1 compressor. In the latter mode, two switches control whether the surround and LEF channels are included in the side chain gain reduction processing. S/C 1 defeats the normal dominant signal side chain operation and substitutes a summing mode so that the gain reduction is proportional to the sound field energy (as opposed to the loudest individual

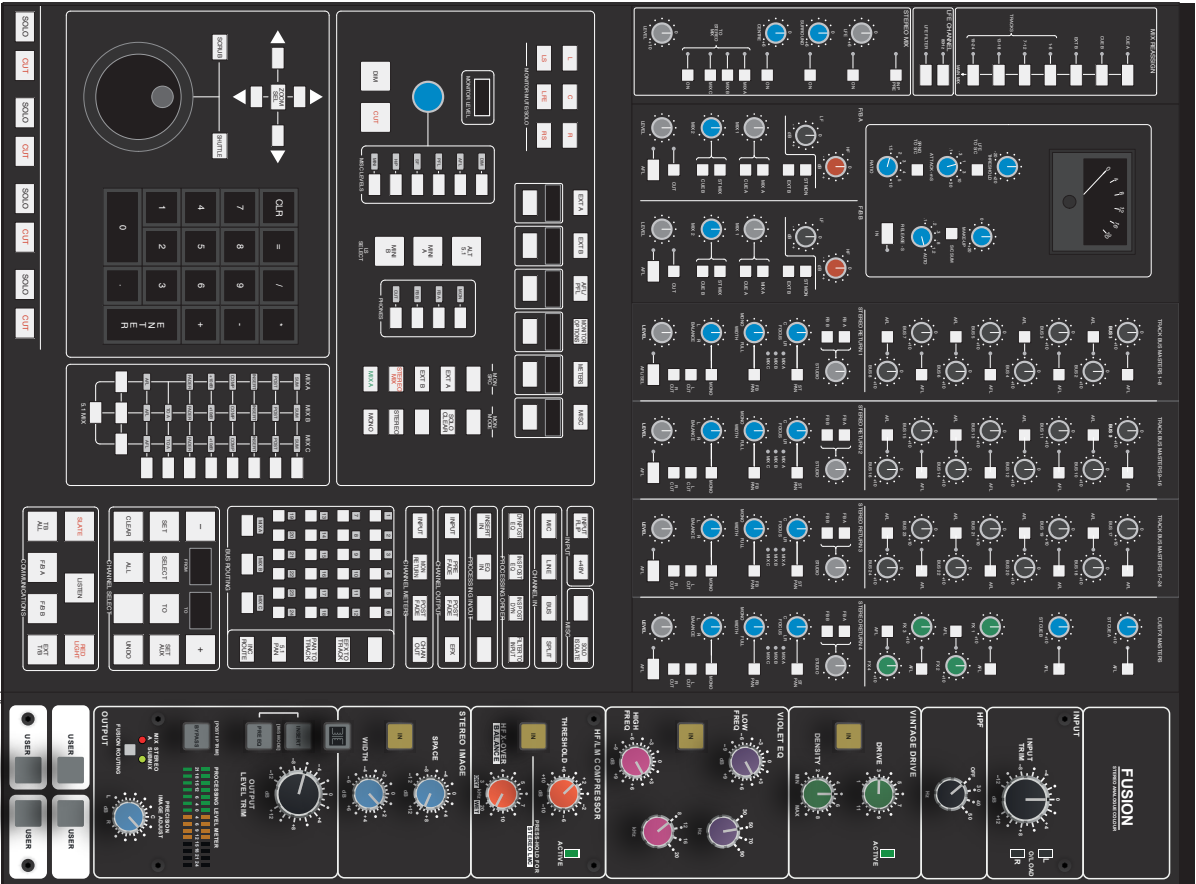

## Track Bus Masters

Three identical sets of controls which provide level trim and monitoring for the twenty four track busses. AFL is mono if a single bus is active and stereo for an odd/even pair selection. mix bus is controlled via the output matrix switch panel.

## Fusion Processing

**VOLET EQ** - a new SSL shelving EQ with a refined  $\pm 9$ dB gain range.  
**HF COMPRESSOR** - tames unwanted top-end brightness and restores a natural analogue roll-off. Converts to a STEREO LMC circuit to crush submixes such as Drums.  
**VINTAGE DRIVE** - a new non-linear saturation circuit that was tweaked over several months to hone its unique character.  
**STEREO IMAGE** circuit is a way of providing analogue mid-side processing.  
**TRANSFORMER** - The 800C, 1:1 winding transformer and surrounding circuitry adds low end harmonic content and a favourable slight top-end phase-shift.

## Stereo Return Channels.

Each channel accepts a stereo line signal which can be routed to the main console mix busses with full control of level and panning, and independently to the Foldback outputs A and B via the Studio control and associated routing switches. Both feeds can post the individual input Cut switches. Default routing is to main mix busses 1 & 2 (Mix A) via the master Level control.

The Balance control provides a differential L/R gain trim for the stereo input signal. This is followed by a variable stereo width control which can reduce the stereo image to a mono centre phantom point source. The MONO key sums the two inputs and simultaneously alters the action of the Balance control to that of a conventional two channel pan pot. Additional options available for surround panning are FB pan which redesignates the Width control as a Frontback pan pot, and FOCUS which progressively subtracts the front L/R signals and reroutes the sum to the C bus (Bus 3). ST PAN defeats the surround panning options and provides switched routing via the CHANNEL SELECT panel in conjunction with the AFL/SEL key to stereo MIX A, B, and C.

## Channel Functions Switches

Central control of channel input selection, mic input phantom power, solo isolate, process order and IN/OUT status, channel output source and channel meter source.

## Bus Routing

Central control of channel Main and Track Mix bus Routing via twenty four dedicated switches for the track busses and routing switches for the three main mix busses pairs, Mix A, B and C.

## Pan Mode

Selects additional options channel signal routing controlled via the adjacent Bus Routing panel. INC ROUTE works in conjunction with the channel select section and provides incremental bus routing for an array of channels. The selected channels will be incrementally routed to consecutive busses starting from the first bus selected. 5:1 PAN enables the channel 5:1 panning mode and links the MIX A, B & C routing keys to function as a group. PAN TO TRK routes the output of the current channel panning mode to the Track Busses. Stereo panning is between odd/even pairs. 5:1 panning mode routes the track busses into four six channel groups. EXT TO TRK replaces the channel feed to the Track busses with the active EPX send output. Stereo Cue EPX sends are automatically routed to odd/even pairs.

## Channel Select

In conjunction with the local channel select(SEL) switches, provides central access to channel functions controlled by the keys located above the Select area. SELECT enables or disables the panel. The - & + decrement or increment the selected channel or the range of an array of channels. ALL selects all console channels. Used with an active array of channels or the ALL function, SET AUX links Aux switched functions so that a group of channels can be controlled simultaneously. SET and CLEAR provide an alternative approach to routing and channel set up. With SET (or CLEAR) active, bus routing or channel settings can be preset via the central switches and transferred (or removed) from channels via the local SEL switches. The ALL key can be used to set (or clear) all console channels. UNDO undoes the last action.

## Communications

Individual momentary Talkback keys to the two Foldback outputs and to the dedicated External Talkback output. Separate level adjustment is available for the Foldback and External Talkback sends. TB ALL is a Master talkback key to all outputs. SLATE (also momentary) routes the talkback signal to the console busses via its own level control. LISTEN is a latching function which routes a return (reverse) talkback feed to the currently selected MAIN monitor output via the Listen Level control. RED Light is a latching switch which controls a pair of isolated relay contacts for external DC signalling control.

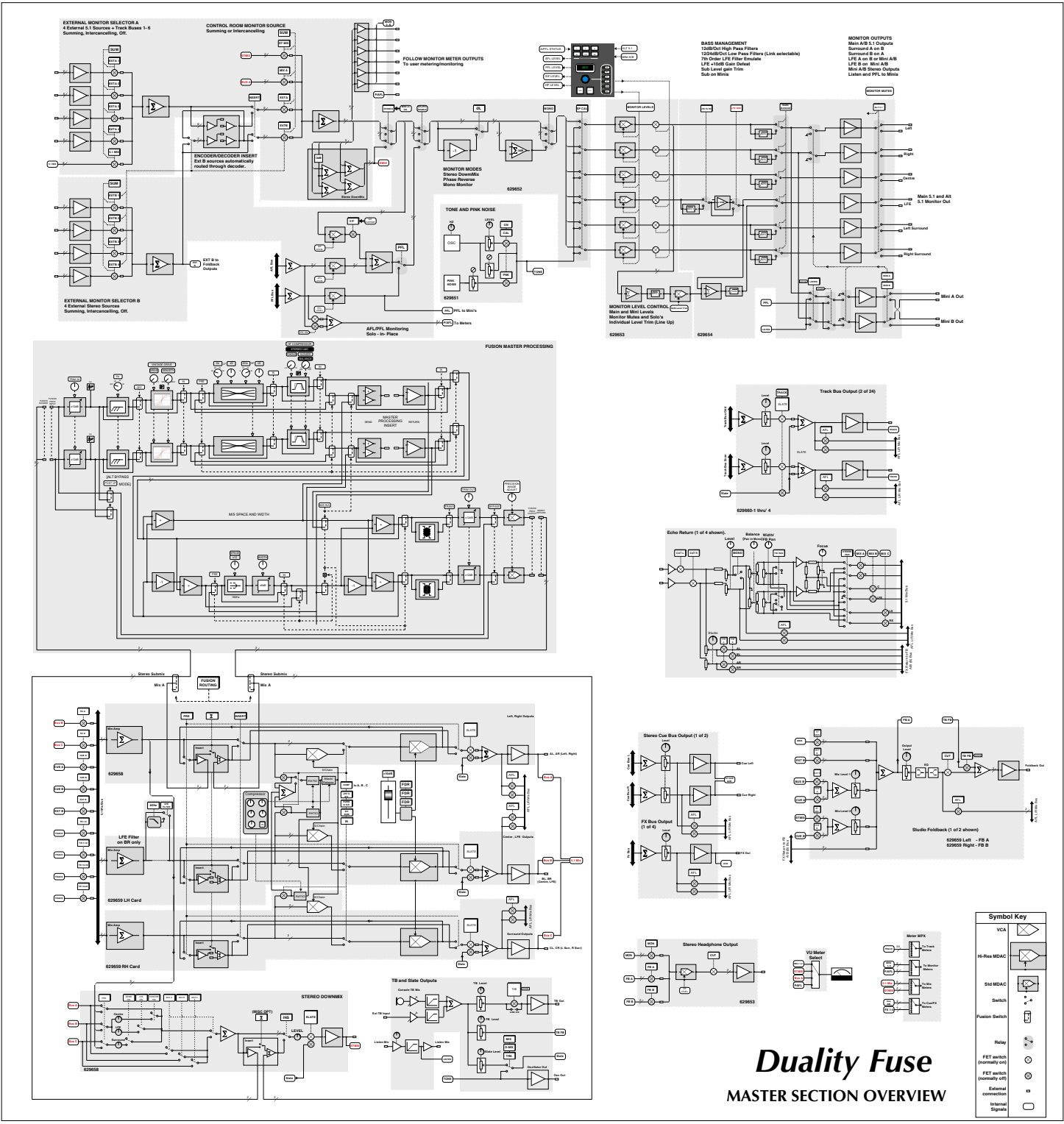

# Duality Fuse

## MASTER SECTION OVERVIEW

Symbol Key	
	VCA
	M-Res MDAC
	Sd MDAC
	Switch
	Pushon Switch
	Relay
	FET switch (normally on)
	FET switch (normally off)
	External connection
	Internal Signal

***Duality  
Fuse***

Operator's  
Manual

82BDYP01H

***Duality  
Fuse***

Operator's  
Manual

82BDYP01H